



STONEBROOK AT BRIDLE GATE

BRENTWOOD, CA

SHEET INDEX

ARCHITECTURE

C.0 COVER SHEET

- C.1 OVERALL MASTER PLOTTING PLAN
- C.2 PARTIAL MASTER PLOTTING PLAN
- C.3 PARTIAL MASTER PLOTTING PLAN

- 1.1 PLAN 1 - FRONT ELEVATIONS
- 1.2 PLAN 1 - SITE PLAN
- 1.3 PLAN 1 - FLOOR PLAN
- 1.4 PLAN 1 - ELEVATIONS 'A'
- 1.5 PLAN 1 - ELEVATIONS 'C'
- 1.6 PLAN 1 - ELEVATIONS 'B'
- 1.7 PLAN 1 - ELEVATIONS 'D'

- 2.1 PLAN 2 - FRONT ELEVATIONS
- 2.2 PLAN 2 - SITE PLAN
- 2.3 PLAN 2 - FLOOR PLAN
- 2.4 PLAN 2 - ELEVATIONS 'A'
- 2.5 PLAN 2 - ELEVATIONS 'C'
- 2.6 PLAN 2 - ELEVATIONS 'B'
- 2.7 PLAN 2 - ELEVATIONS 'D'

- 3.1 PLAN 3 - FRONT ELEVATIONS
- 3.2 PLAN 3 - SITE PLAN
- 3.3 PLAN 3 - FLOOR PLAN
- 3.4 PLAN 3 - ELEVATIONS 'A'
- 3.5 PLAN 3 - ELEVATIONS 'C'
- 3.6 PLAN 3 - ELEVATIONS 'B'
- 3.7 PLAN 3 - ELEVATIONS 'D'

- 4.1 PLAN 4 - FRONT ELEVATIONS
- 4.2 PLAN 4 - SITE PLAN
- 4.3 PLAN 4 - FIRST FLOOR PLAN
- 4.4 PLAN 4 - SECOND FLOOR PLAN
- 4.5 PLAN 4 - ELEVATIONS 'A'
- 4.6 PLAN 4 - ELEVATIONS 'B'
- 4.7 PLAN 4 - ELEVATIONS 'C'
- 4.8 PLAN 4 - ELEVATIONS 'D'

- 5.1 PLAN 5 - FRONT ELEVATIONS
- 5.2 PLAN 5 - SITE PLAN
- 5.3 PLAN 5 - FIRST FLOOR PLAN
- 5.4 PLAN 5 - SECOND FLOOR PLAN
- 5.5 PLAN 5 - ELEVATIONS 'A'
- 5.6 PLAN 5 - ELEVATIONS 'B'
- 5.7 PLAN 5 - ELEVATIONS 'C'
- 5.8 PLAN 4 - ELEVATIONS 'D'

- 6.1 PLAN 6 - FRONT ELEVATIONS
- 6.2 PLAN 6 - SITE PLAN
- 6.3 PLAN 6 - FIRST FLOOR PLAN
- 6.4 PLAN 6 - SECOND FLOOR PLAN
- 6.5 PLAN 6 - ELEVATIONS 'A'
- 6.6 PLAN 6 - ELEVATIONS 'B'
- 6.7 PLAN 6 - ELEVATIONS 'C'
- 6.8 PLAN 6 - ELEVATIONS 'D'

- 7.1 PLAN 7 - FRONT ELEVATIONS
- 7.2 PLAN 7 - SITE PLAN
- 7.3 PLAN 7 - FIRST FLOOR PLAN
- 7.4 PLAN 7 - SECOND FLOOR PLAN
- 7.5 PLAN 7 - ELEVATIONS 'A'
- 7.6 PLAN 7 - ELEVATIONS 'B'
- 7.7 PLAN 7 - ELEVATIONS 'C'
- 7.8 PLAN 7 - ELEVATIONS 'D'

- 8.1 PLAN 8 - FRONT ELEVATIONS
- 8.2 PLAN 8 - SITE PLAN
- 8.3 PLAN 8 - FIRST FLOOR PLAN
- 8.4 PLAN 8 - SECOND FLOOR PLAN
- 8.5 PLAN 8 - ELEVATIONS 'A'
- 8.6 PLAN 8 - ELEVATIONS 'B'
- 8.7 PLAN 8 - ELEVATIONS 'C'
- 8.8 PLAN 8 - ELEVATIONS 'D'

- 9.1 PLAN 9 - FRONT ELEVATIONS
- 9.2 PLAN 9 - SITE PLAN
- 9.3 PLAN 9 - FIRST FLOOR PLAN
- 9.4 PLAN 9 - SECOND FLOOR PLAN
- 9.5 PLAN 9 - ELEVATIONS 'A'
- 9.6 PLAN 9 - ELEVATIONS 'B'
- 9.7 PLAN 9 - ELEVATIONS 'C'
- 9.8 PLAN 9 - ELEVATIONS 'D'

- 10.1 PLAN 10 - FRONT ELEVATIONS
- 10.2 PLAN 10 - SITE PLAN
- 10.3 PLAN 10 - FIRST FLOOR PLAN
- 10.4 PLAN 10 - SECOND FLOOR PLAN
- 10.5 PLAN 10 - ELEVATIONS 'A'
- 10.6 PLAN 10 - ELEVATIONS 'B'
- 10.7 PLAN 10 - ELEVATIONS 'C'
- 10.8 PLAN 10 - ELEVATIONS 'D'

- 11.1 PLAN 11 - FRONT ELEVATIONS
- 11.2 PLAN 11 - SITE PLAN
- 11.3 PLAN 11 - FIRST FLOOR PLAN
- 11.4 PLAN 11 - SECOND FLOOR PLAN
- 11.5 PLAN 11 - ELEVATIONS 'A'
- 11.6 PLAN 11 - ELEVATIONS 'B'
- 11.7 PLAN 11 - ELEVATIONS 'C'
- 11.8 PLAN 11 - ELEVATIONS 'D'

- 12.1 PLAN 12 - FRONT ELEVATIONS
- 12.2 PLAN 12 - SITE PLAN
- 12.3 PLAN 12 - FIRST FLOOR PLAN
- 12.4 PLAN 12 - SECOND FLOOR PLAN
- 12.5 PLAN 12 - ELEVATIONS 'A'
- 12.6 PLAN 12 - ELEVATIONS 'B'
- 12.7 PLAN 12 - ELEVATIONS 'C'
- 12.8 PLAN 12 - ELEVATIONS 'D'

- 13.1 PLAN 13 - FRONT ELEVATIONS
- 13.2 PLAN 13 - SITE PLAN
- 13.3 PLAN 13 - ENTRY LEVEL FLOOR PLAN
- 13.4 PLAN 13 - MAIN LEVEL FLOOR PLAN
- 13.5 PLAN 13 - UPPER LEVEL FLOOR PLAN
- 13.6 PLAN 13 - ELEVATIONS 'A'
- 13.7 PLAN 13 - ELEVATIONS 'B'

- 0.1 COLOR BOARD
- 0.2 COLOR BOARD
- 0.3 COLOR BOARD
- 0.4 COLOR BOARD

**West Coast
HOME BUILDERS**

**LEGACY
DESIGN GROUP**

July 01, 2024

C.0

DISTRIBUTION

PLAN#	1 SINGLE STORY	2 SINGLE STORY	3 SINGLE STORY	4 TWO STORY	5 TWO STORY	6 TWO STORY	7 TWO STORY	8 TWO STORY	9 TWO STORY	10 TWO STORY	11 TWO STORY	12 TWO STORY	13 THREE STORY
COUNT	20	20	20	23	24	25	24	24	22	22	22	24	2
PERCENT	7.4%	7.4%	7.4%	8.5%	8.8%	9.1%	8.8%	8.8%	8.1%	8.1%	8.1%	8.8%	0.7%

GRAND TOTAL HOMES: 272
TOTAL PERCENT: 100%

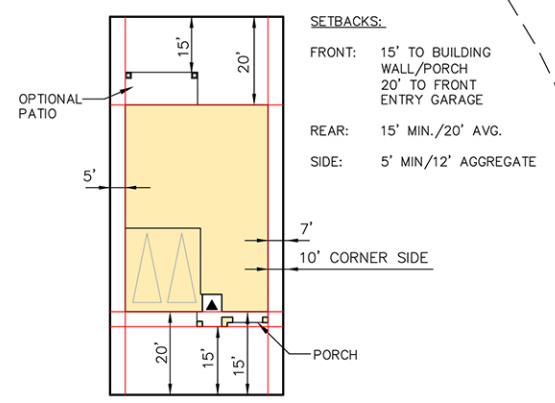

TYPICAL MINIMUM LOT SETBACKS
N.T.S.

STONEBROOK MASTER PLOTTING PLAN
BRENTWOOD, CA

West Coast HOME BUILDERS
LEGACY DESIGN GROUP
July 01, 2024

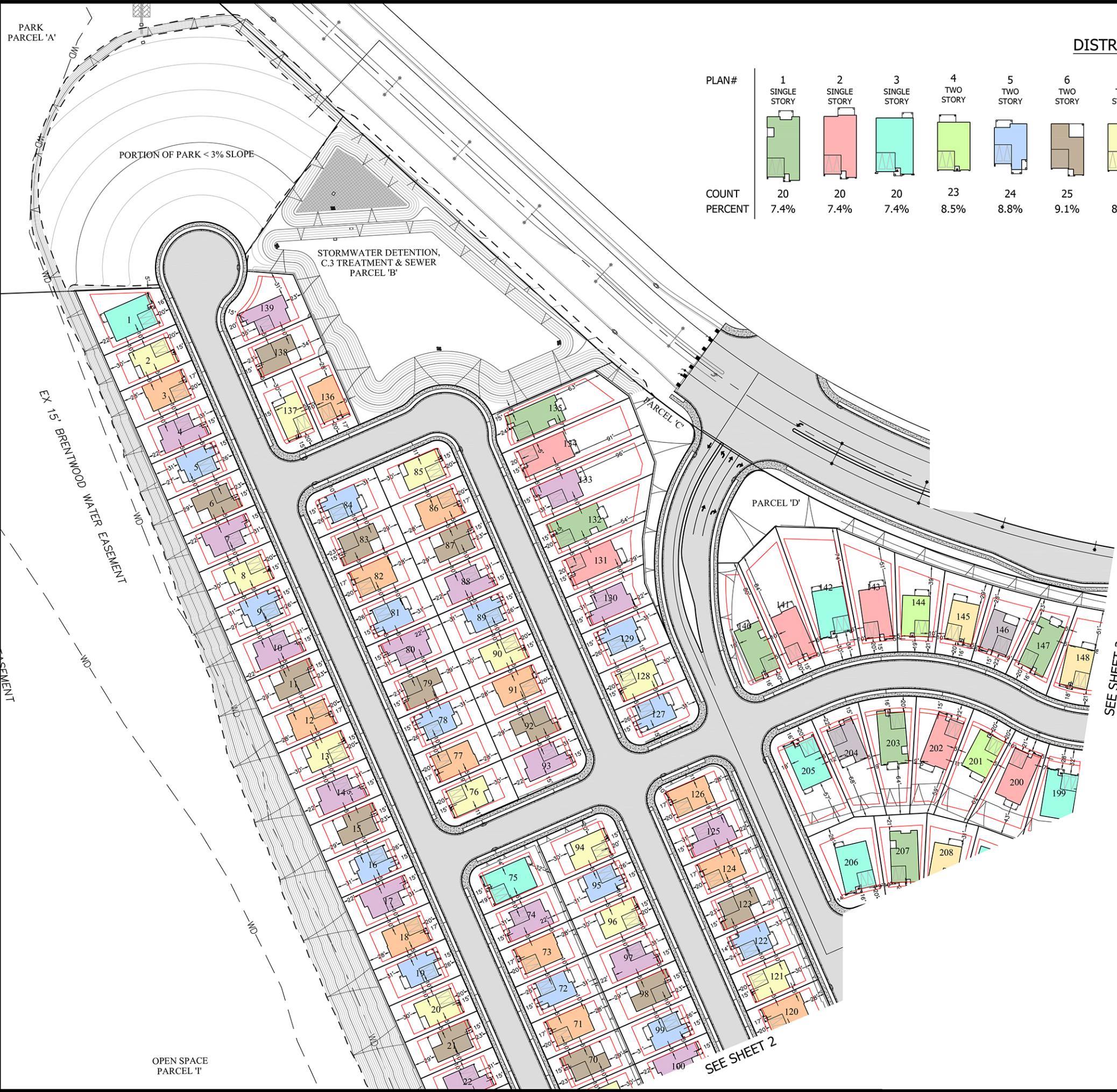

DISTRIBUTION

PLAN#	1 SINGLE STORY	2 SINGLE STORY	3 SINGLE STORY	4 TWO STORY	5 TWO STORY	6 TWO STORY	7 TWO STORY	8 TWO STORY	9 TWO STORY	10 TWO STORY	11 TWO STORY	12 TWO STORY	13 THREE STORY
COUNT	20	20	20	23	24	25	24	24	22	22	22	24	2
PERCENT	7.4%	7.4%	7.4%	8.5%	8.8%	9.1%	8.8%	8.8%	8.1%	8.1%	8.1%	8.8%	0.7%

GRAND TOTAL
HOMES: 272
TOTAL PERCENT: 100%

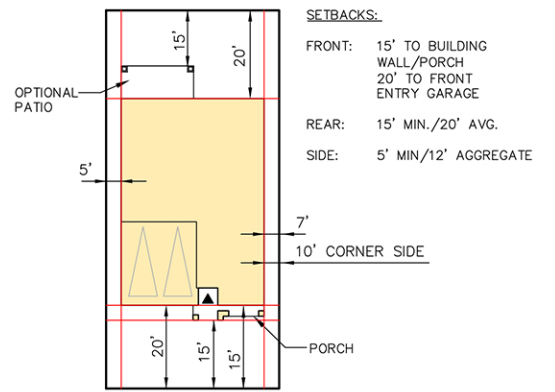
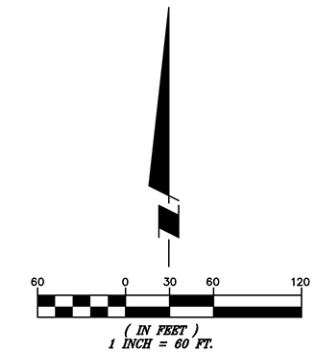

TYPICAL MINIMUM LOT SETBACKS
N.T.S.

**STONEBROOK
MASTER PLOTTING PLAN
BRENTWOOD, CA**

West Coast
HOME BUILDERS
LEGACY
DESIGN GROUP
July 01, 2024

STONEBROOK MASTER PLOTING PLAN

BRENTWOOD, CA



SHEET 2 OF 2

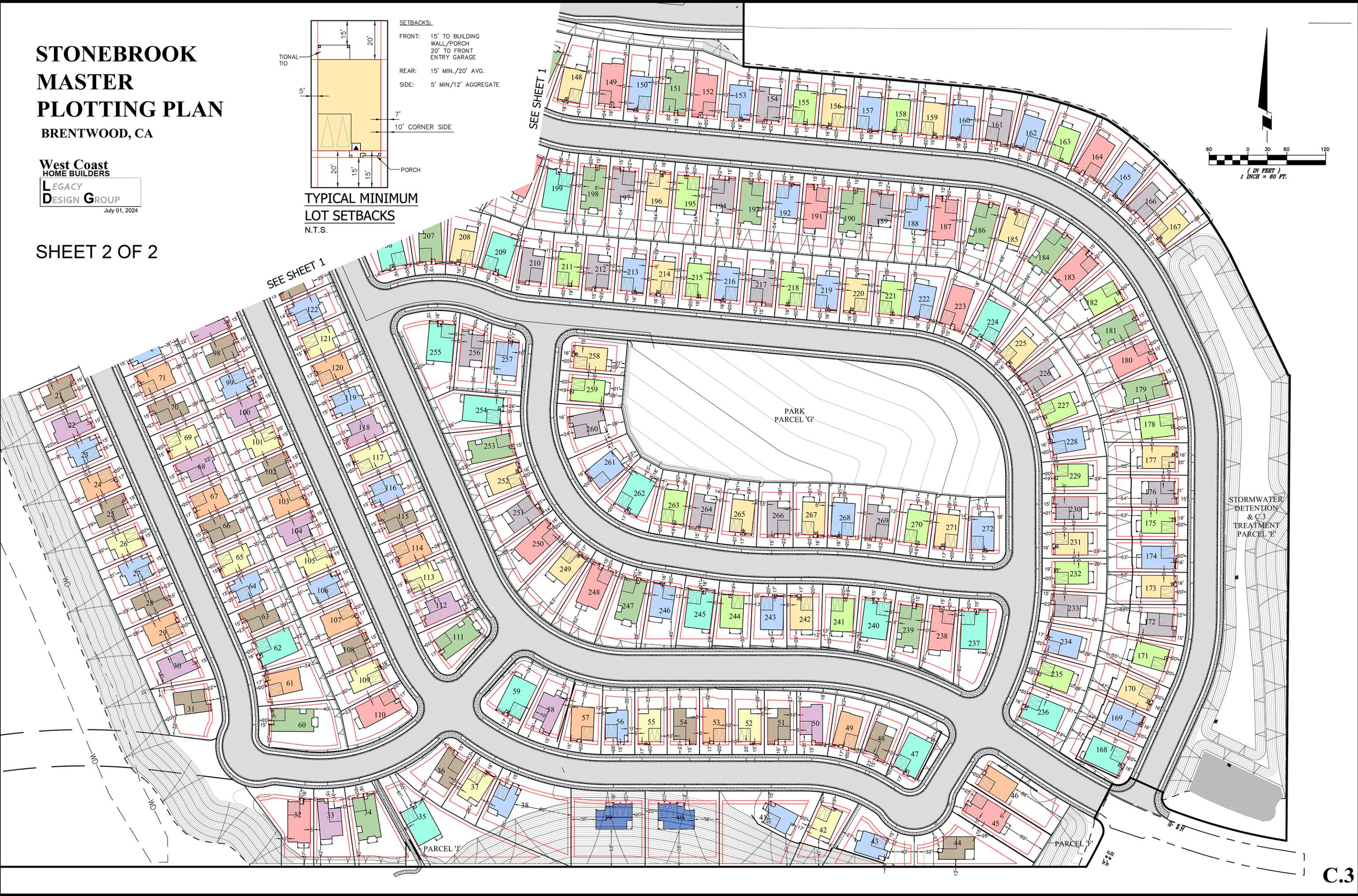
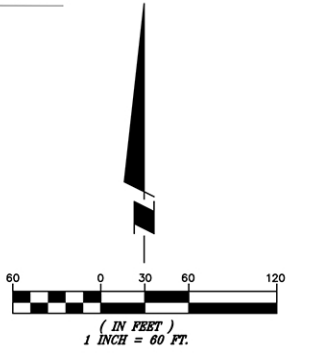
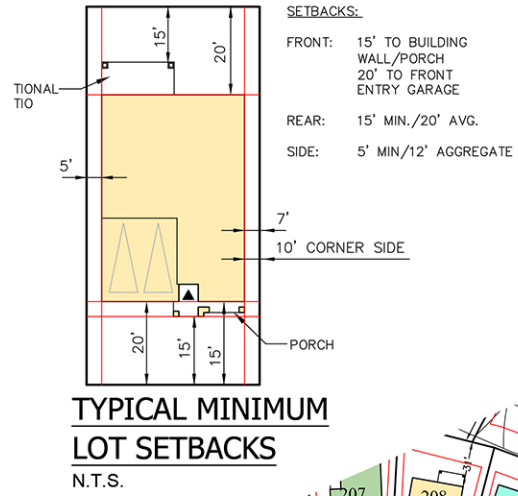



Elevation A - Tuscan



Elevation B - French Cottage



Elevation C - Craftsman



Elevation D - Bay Area Modern

MATERIAL LEGEND

- | | |
|---|--|
| <p>A VILLA CONCRETE TILE ROOFING
HIP & GABLE ROOFS
STUCCO BODY
STUCCO/FOAM TRIM
SIMULATED BRICK VENEER
STUCCO/FOAM CORBELS
DECORATIVE WROUGHT IRON
DECORATIVE FOAM
ROLL-UP GARAGE DOORS
W/ OPT. WINDOW LITES</p> | <p>B FLAT CONCRETE TILE ROOFING
GABLE ROOFS
STUCCO BODY
STUCCO/FOAM TRIM
MOCK VENTS
SIMULATED STONE VENEER
DECORATIVE FOAM
ROLL-UP GARAGE DOORS
W/ OPT. WINDOW LITES</p> |
| <p>C FLAT CONCRETE TILE ROOFING
HIP & GABLE ROOFS
STUCCO BODY
STUCCO/FOAM TRIM
WOOD SHAKES
DECORATIVE FOAM
STUCCO/FOAM CORBELS
SIMULATED STONE VENEER
ROLL-UP GARAGE DOORS
W/ OPT. WINDOW LITES</p> | <p>D FLAT CONCRETE TILE ROOFING
GABLE ROOFS
STUCCO BODY
STUCCO/FOAM TRIM
BOARD & BATTEN
MOCK VENTS
MOCK WOOD SHUTTERS
WOOD KICKERS
DECORATIVE FOAM
SIMULATED STONE VENEER
ROLL-UP GARAGE DOORS
W/ OPT. WINDOW LITES</p> |

PLAN 1
Front Elevations
STONEBROOK
BRENTWOOD, CA

West Coast
HOME BUILDERS

LEGACY
DESIGN GROUP

DATE JULY 01, 2024

1.1

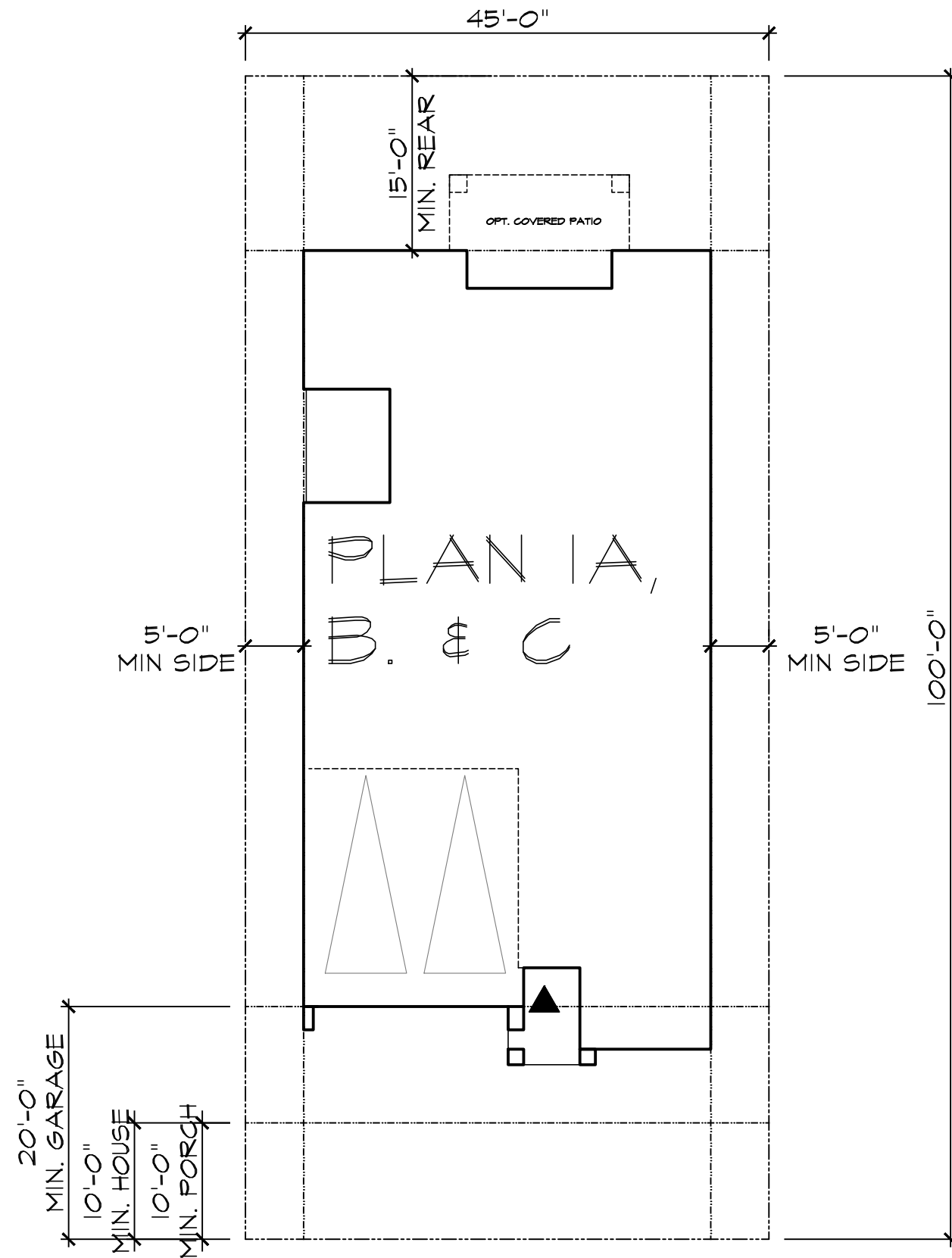

City of Brentwood
MINIMUM REQUIREMENTS

FRONT SETBACK - TO LIVING	10' MIN.
FRONT SETBACK - TO GARAGE	20' MIN.
SIDE YARD - SETBACK	5' MIN.
REAR YARD - SETBACK	15' MIN.
PORCH SETBACK	10' MIN.
LOT SIZE -	4,500 SQ. FT.
MAX COVERAGE - 1-STORY	50%

LOT COVERAGE 1-STORY: 50% max		
TYPICAL LOT SIZES	FOOTPRINT	APPROX. COVERAGE
45' x 100' = 4,500 SQ. FT.	2,236 SQ. FT.	49%



PLAN 1

SitePlan

STONEBROOK

BRENTWOOD, CA

West Coast
HOME BUILDERS

LEGACY
DESIGN GROUP

DATE JULY 01, 2024

1.2

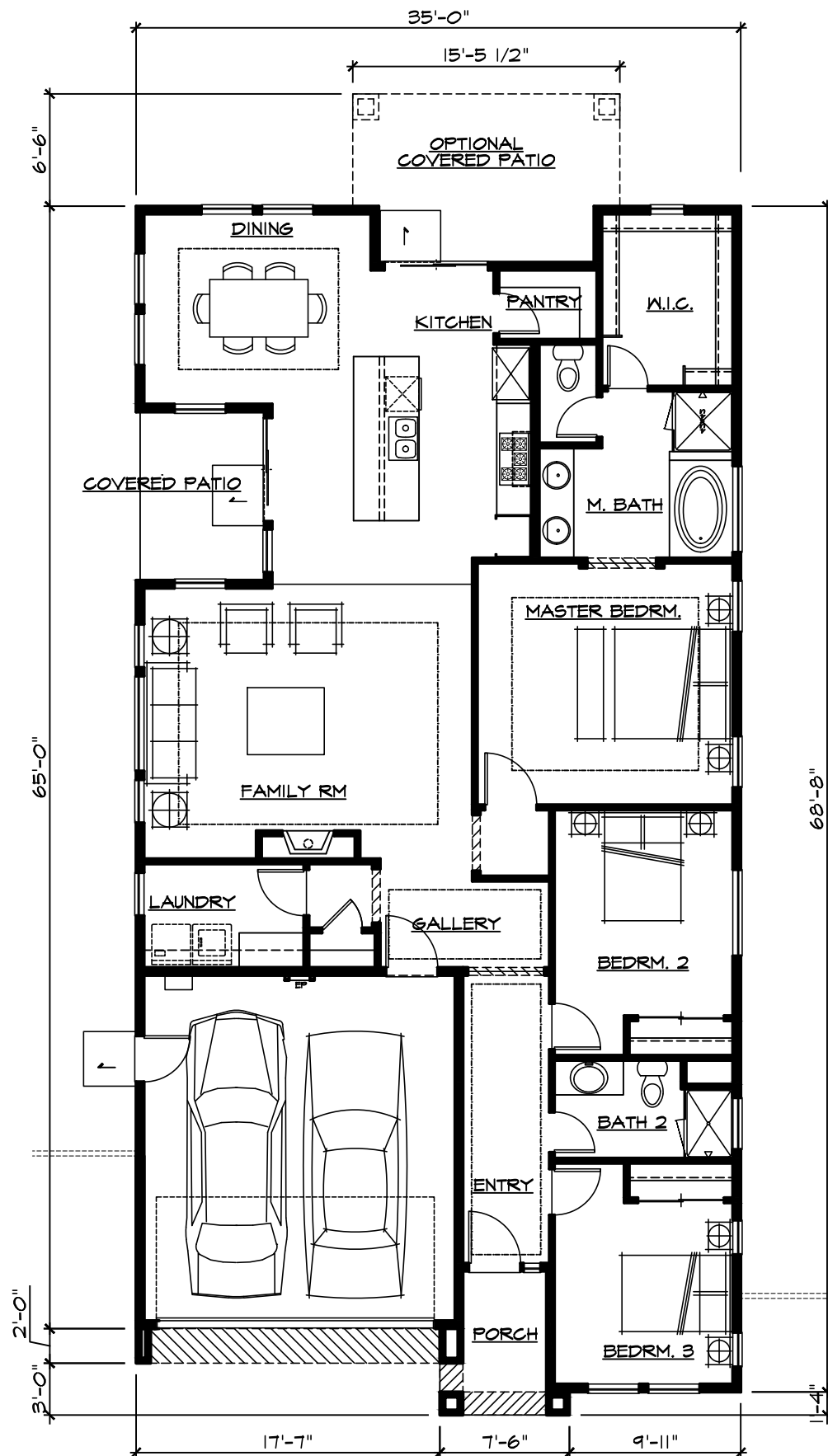

SQUARE FOOTAGE	
FIRST FLOOR	1808 SF
TOTAL LIVING AREA	1808 SF
GARAGE	379 SF
PORCH	49 SF
SIDE PATIO	72 SF
OPT. REAR PATIO	141 SF
FOOTPRINT	2236 SF

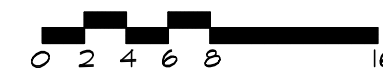

PLAN 1

Floor Plan

STONEBROOK

BRENTWOOD, CA

West Coast
HOME BUILDERS

LEGACY
DESIGN GROUP

DATE JULY 01, 2024

1.3

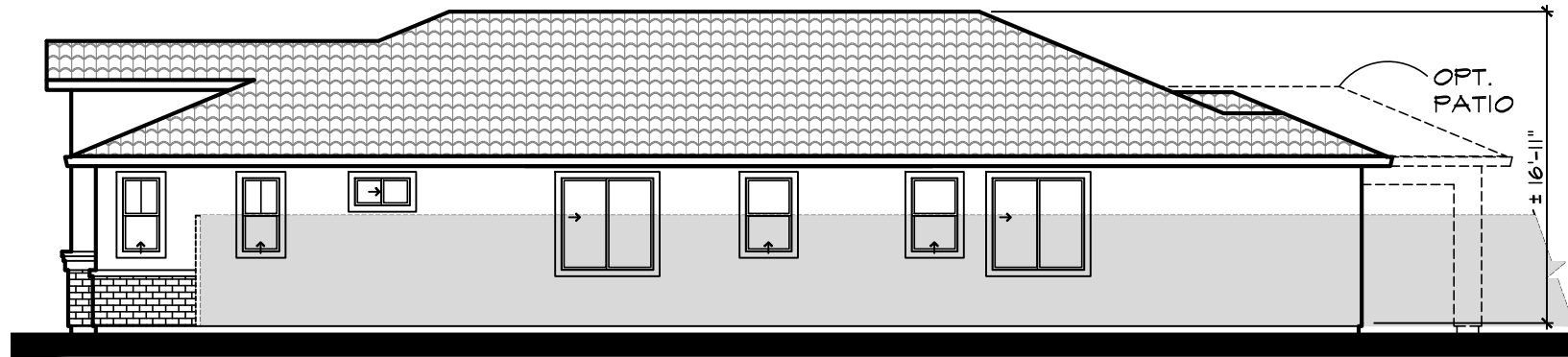

Right



Front - Tuscan

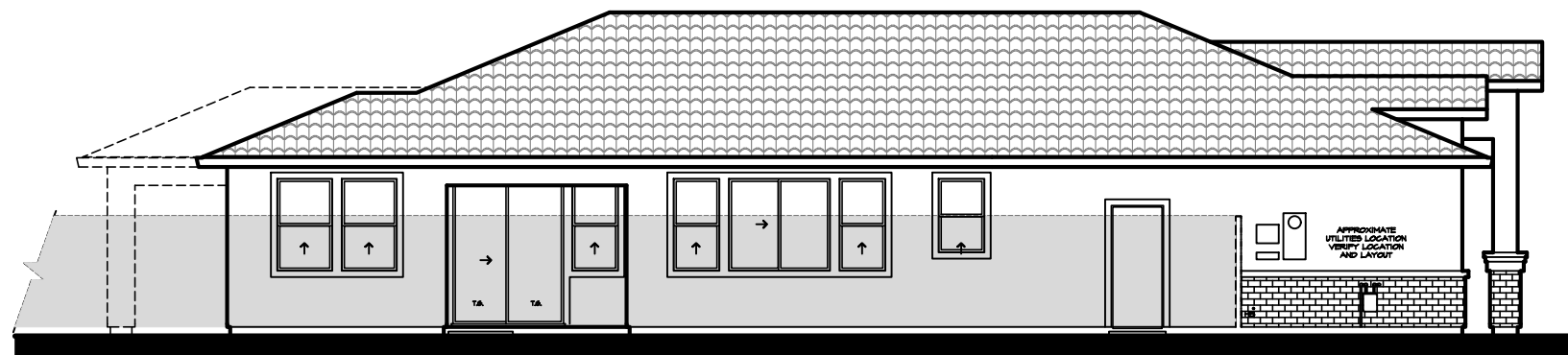
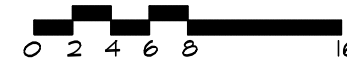

Left

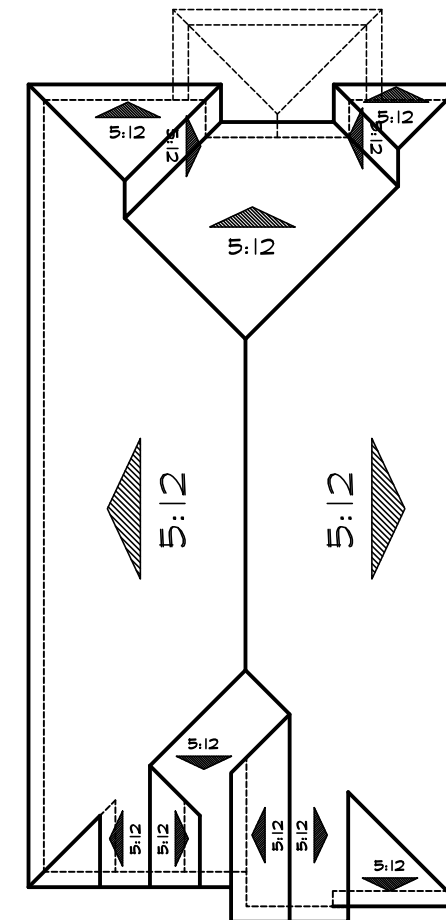

Roof Plan 'A'

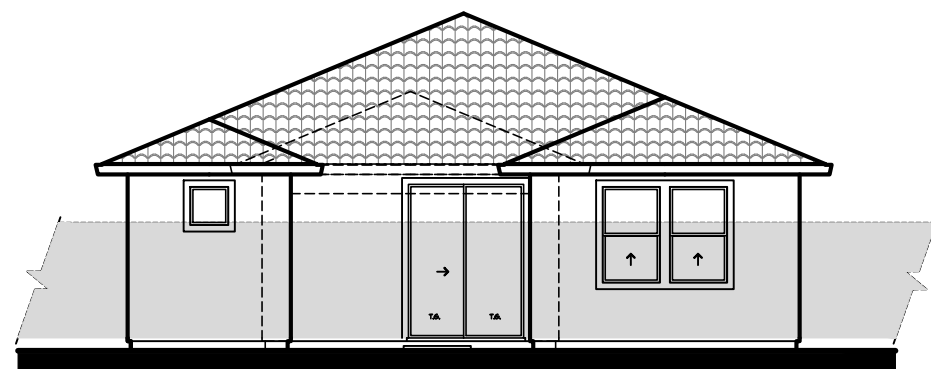

Rear

PLAN 1
Elevation A
STONEBROOK

BRENTWOOD, CA

West Coast
HOME BUILDERS

LEGACY
DESIGN GROUP

DATE JULY 01, 2024

1.4

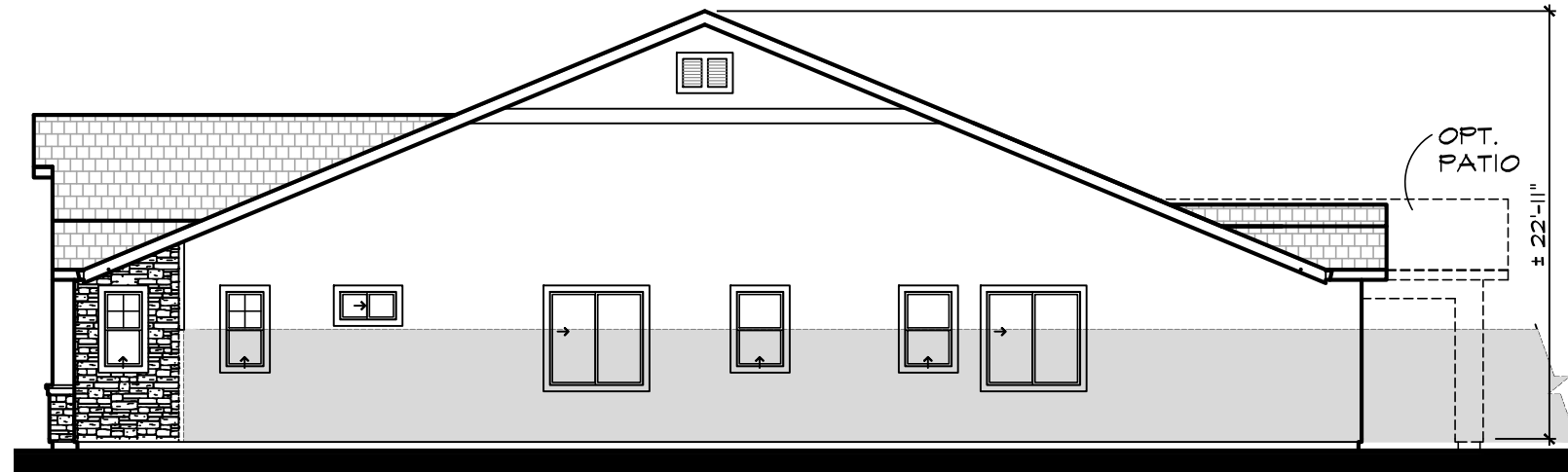

Right



Front - French Cottage

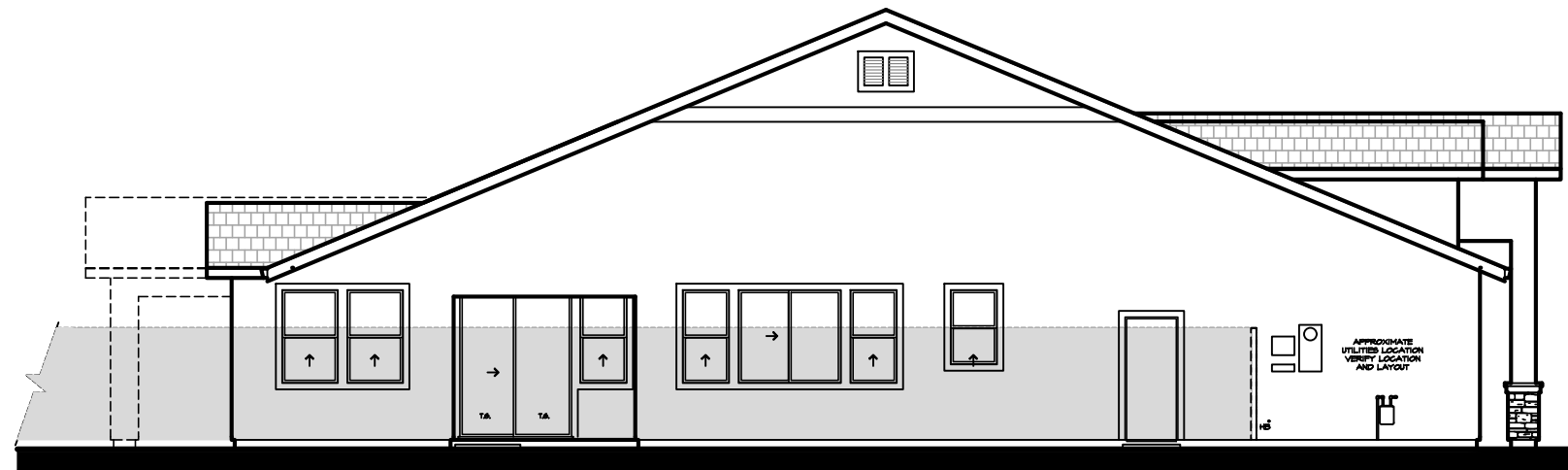
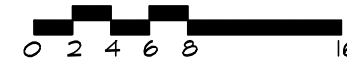

Left

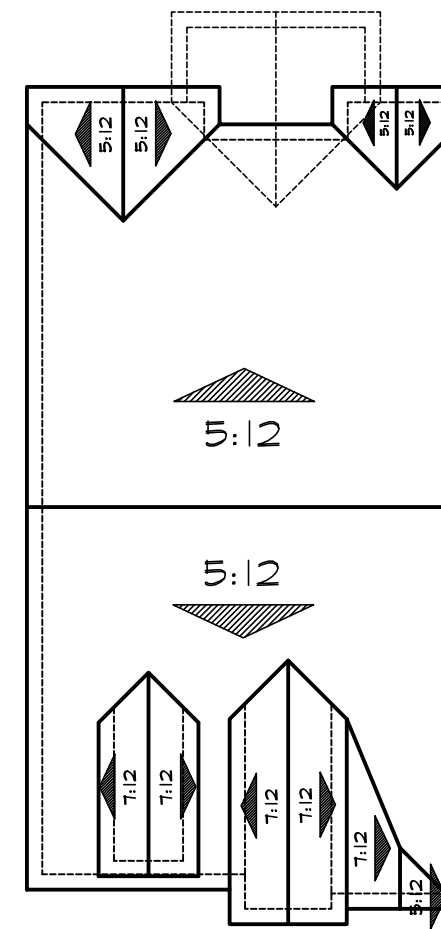

Roof Plan 'B'

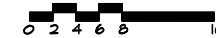

Rear

PLAN 1
Elevation B
STONEBROOK

BRENTWOOD, CA

West Coast
 HOME BUILDERS

LEGACY
 DESIGN GROUP

DATE JULY 01, 2024

1.5

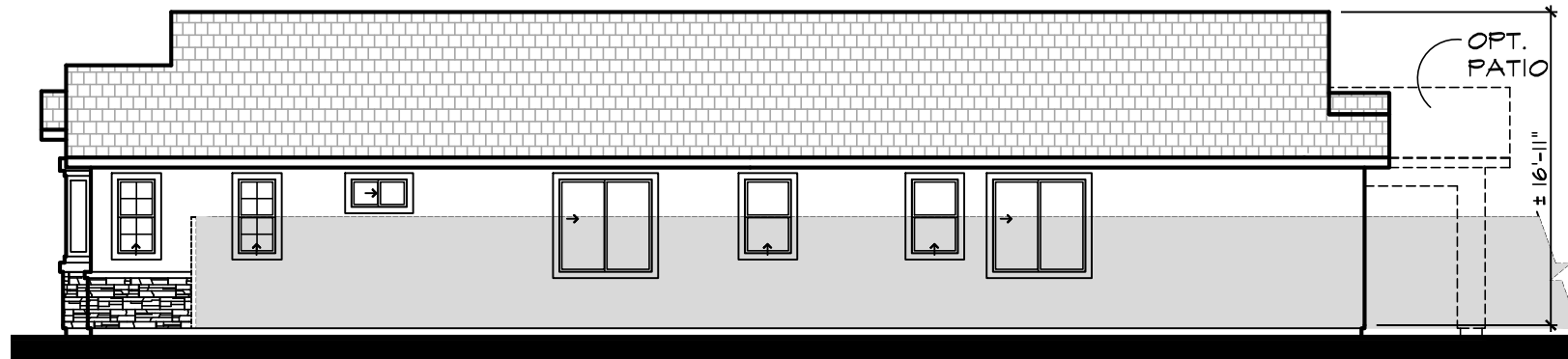

Right



Front - Craftsman

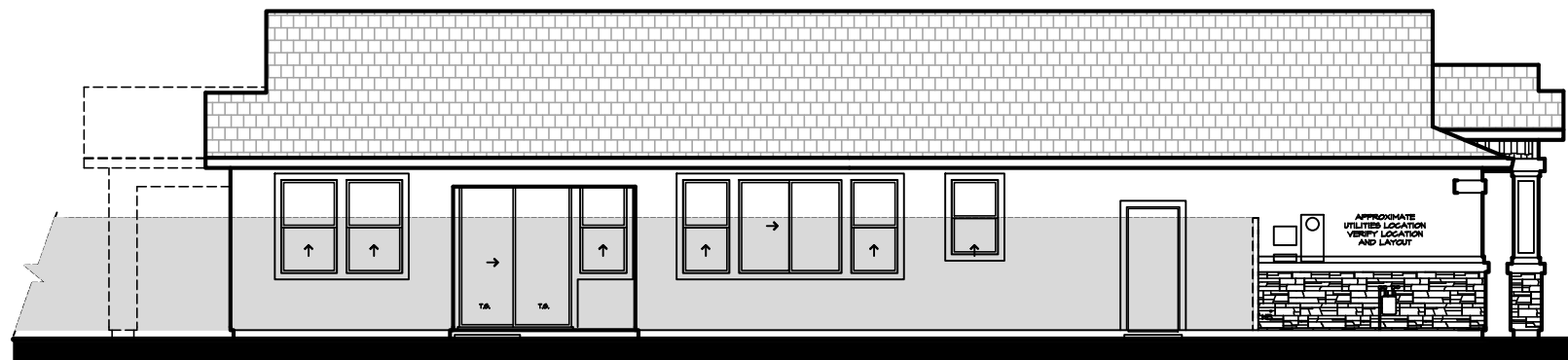
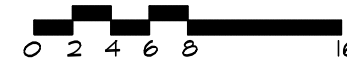

Left

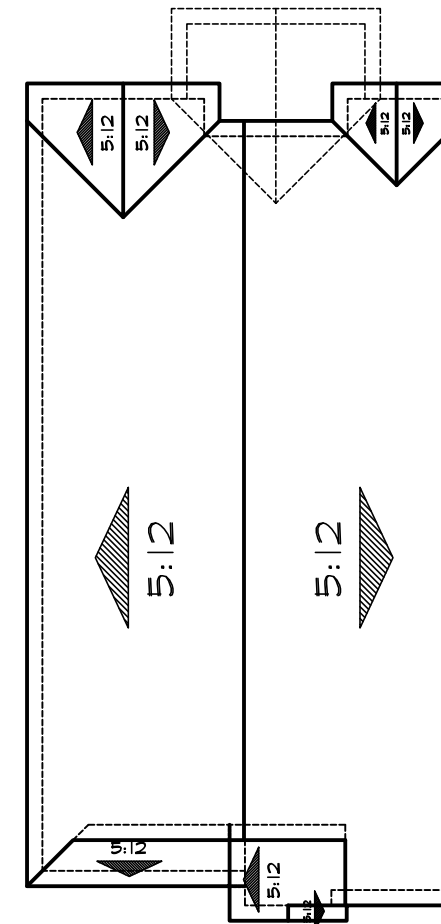

Roof Plan 'C'



Rear

PLAN 1
Elevation C
STONEBROOK
 BRENTWOOD, CA

West Coast
 HOME BUILDERS

LEGACY
DESIGN GROUP

DATE JULY 01, 2024

1.6

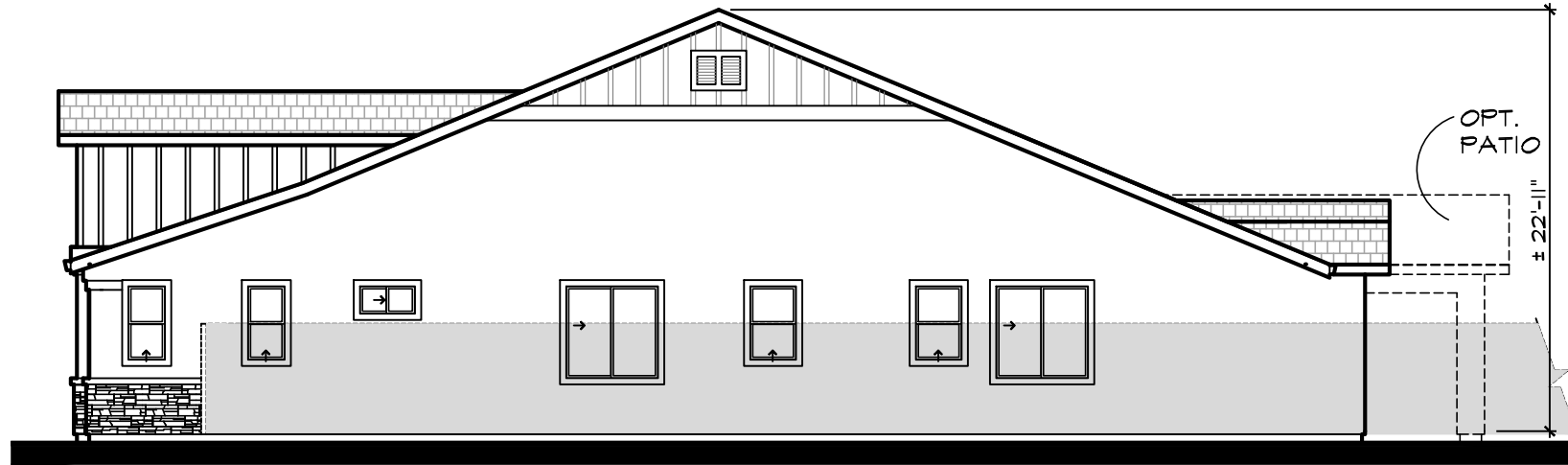

Right



Front - Bay Area Modern

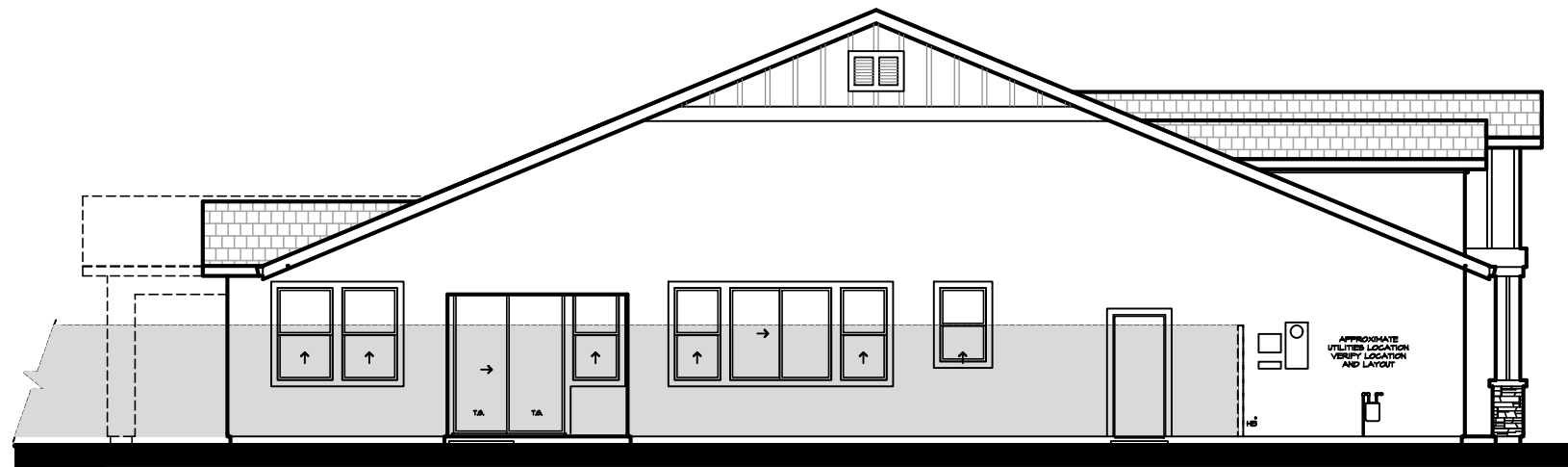
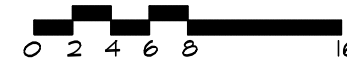

Left

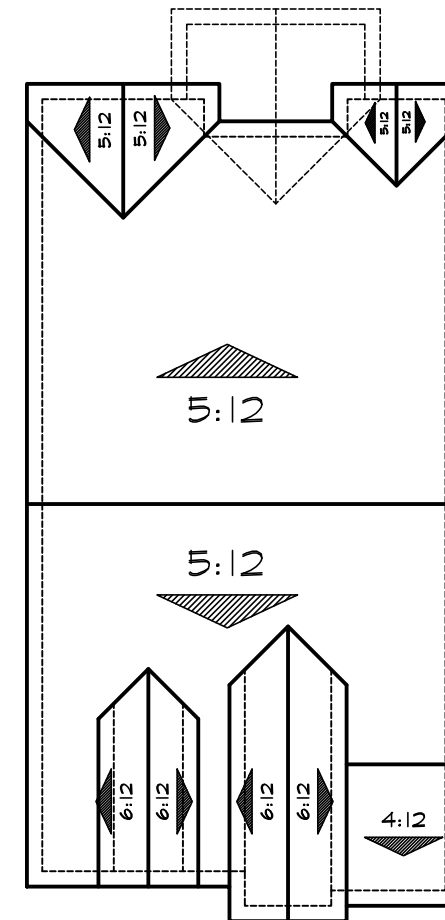

Roof Plan 'D'



Rear

PLAN 1
Elevation D
STONEBROOK

BRENTWOOD, CA

West Coast
HOME BUILDERS

LEGACY
DESIGN GROUP

DATE JULY 01, 2024

1.7



Elevation A - Tuscan



Elevation B - French Cottage



Elevation C - Craftsman



Elevation D - Bay Area Modern

MATERIAL LEGEND

- | | |
|--|---|
| <p>A VILLA CONCRETE TILE ROOFING
HIP & GABLE ROOFS
STUCCO BODY
STUCCO/FOAM TRIM
SIMULATED BRICK VENEER
STUCCO/FOAM CORBELS
DECORATIVE WROUGHT IRON
DECORATIVE FOAM
ROLL-UP GARAGE DOORS
W/ OPT. WINDOW LITES</p> | <p>B FLAT CONCRETE TILE ROOFING
GABLE ROOFS
STUCCO BODY
STUCCO/FOAM TRIM
MOCK VENTS
SIMULATED STONE VENEER
MOCK WOOD SHUTTERS
DECORATIVE FOAM
ROLL-UP GARAGE DOORS
W/ OPT. WINDOW LITES</p> |
| <p>C FLAT CONCRETE TILE ROOFING
HIP & GABLE ROOFS
STUCCO BODY
STUCCO/FOAM TRIM
BOARD & BATTEN
LAP SIDING
SIMULATED STONE VENEER
STUCCO/FOAM CORBELS
DECORATIVE FOAM
ROLL-UP GARAGE DOORS
W/ OPT. WINDOW LITES</p> | <p>D FLAT CONCRETE TILE ROOFING
GABLE ROOFS
STUCCO BODY
STUCCO/FOAM TRIM
BOARD & BATTEN
SIMULATED STONE VENEER
MOCK WOOD SHUTTERS
WOOD KICKERS
DECORATIVE FOAM
ROLL-UP GARAGE DOORS
W/ OPT. WINDOW LITES</p> |

PLAN 2
Front Elevations
STONEBROOK

BRENTWOOD, CA

West Coast
HOME BUILDERS

LEGACY
DESIGN GROUP

DATE JULY 01, 2024

2.1

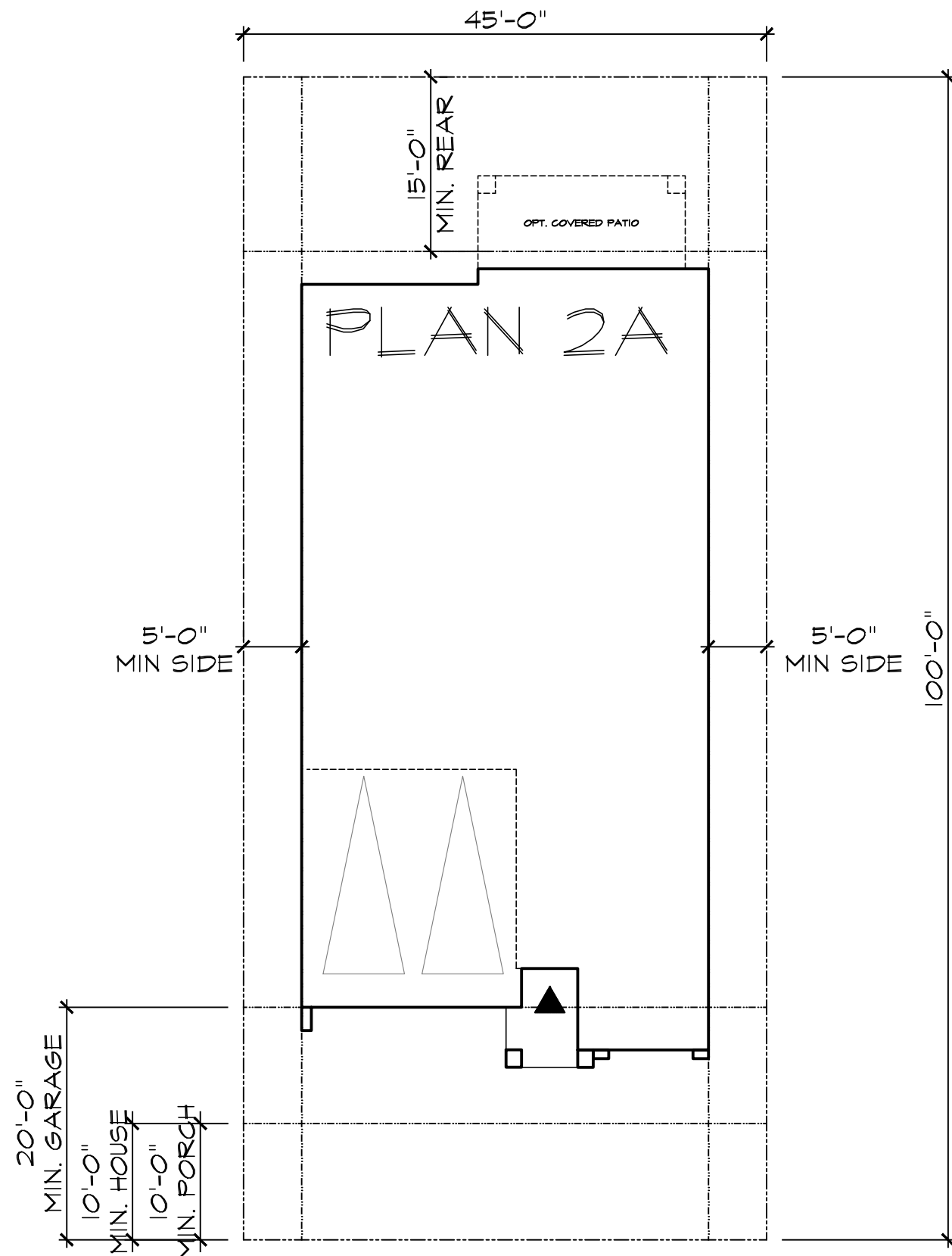

City of Brentwood
MINIMUM REQUIREMENTS

FRONT SETBACK - TO LIVING	10' MIN.
FRONT SETBACK - TO GARAGE	20' MIN.
SIDE YARD - SETBACK	5' MIN.
REAR YARD - SETBACK	15' MIN.
PORCH SETBACK	10' MIN.
LOT SIZE -	4,500 SQ. FT.
MAX COVERAGE - 1-STORY	50%

LOT COVERAGE
1-STORY: 50% max

TYPICAL LOT SIZES	FOOTPRINT	APPROX. COVERAGE
45' x 100' = 4,500 SQ. FT.	2,277 SQ. FT.	50%



PLAN 2
Site Plan
STONEBROOK
BRENTWOOD, CA

West Coast
HOME BUILDERS

LEGACY
DESIGN GROUP

DATE JULY 01, 2024

2.2

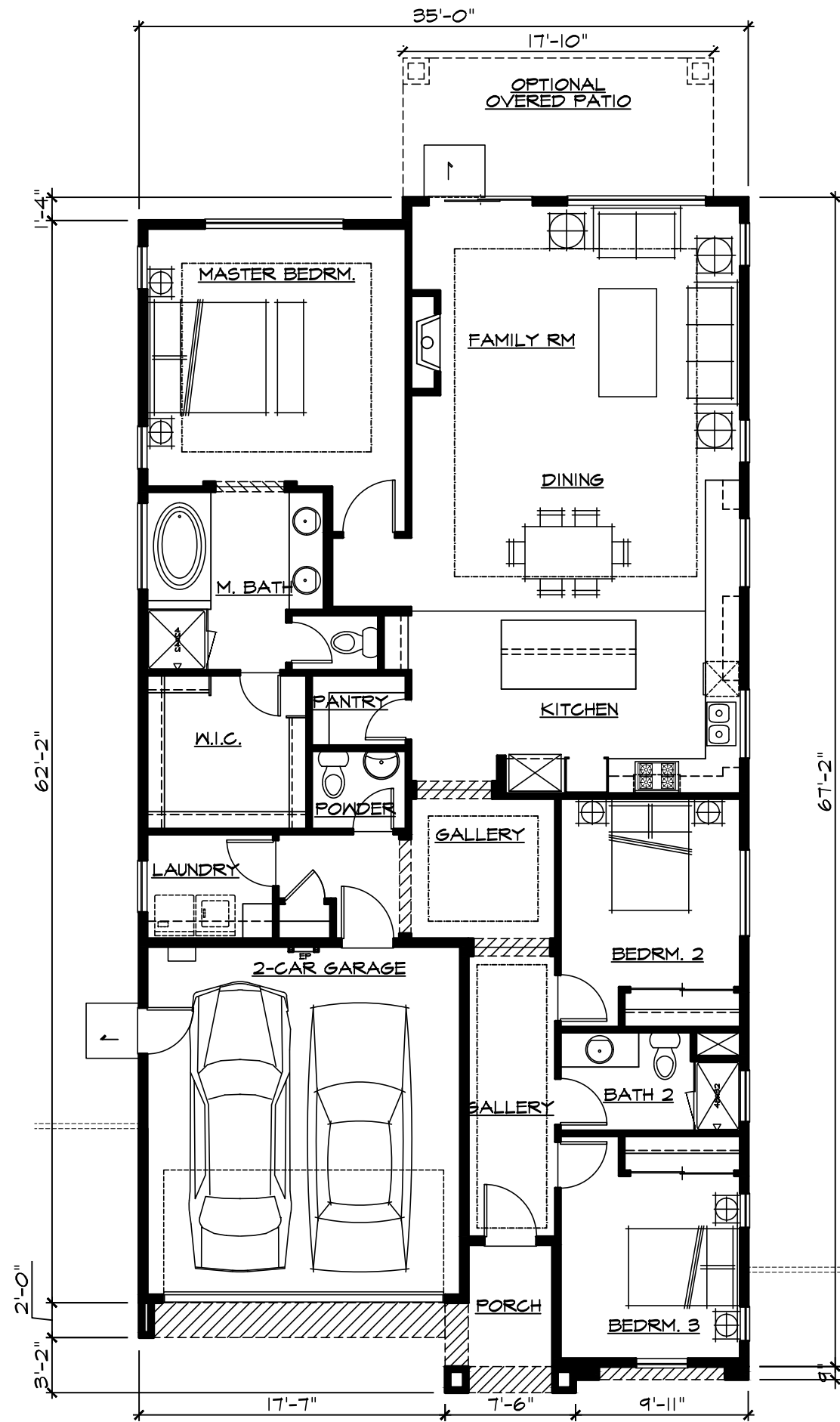

SQUARE FOOTAGE	
FIRST FLOOR	1848 SF
TOTAL LIVING AREA	1848 SF
GARAGE	379 SF
PORCH	50 SF
OPT. REAR PATIO	143 SF
FOOTPRINT	2277 SF

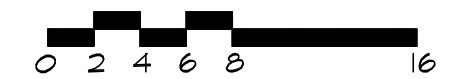

PLAN 2

Floor Plan

STONEBROOK

BRENTWOOD, CA

West Coast
HOME BUILDERS

LEGACY
DESIGN GROUP

DATE JULY 01, 2024

2.3

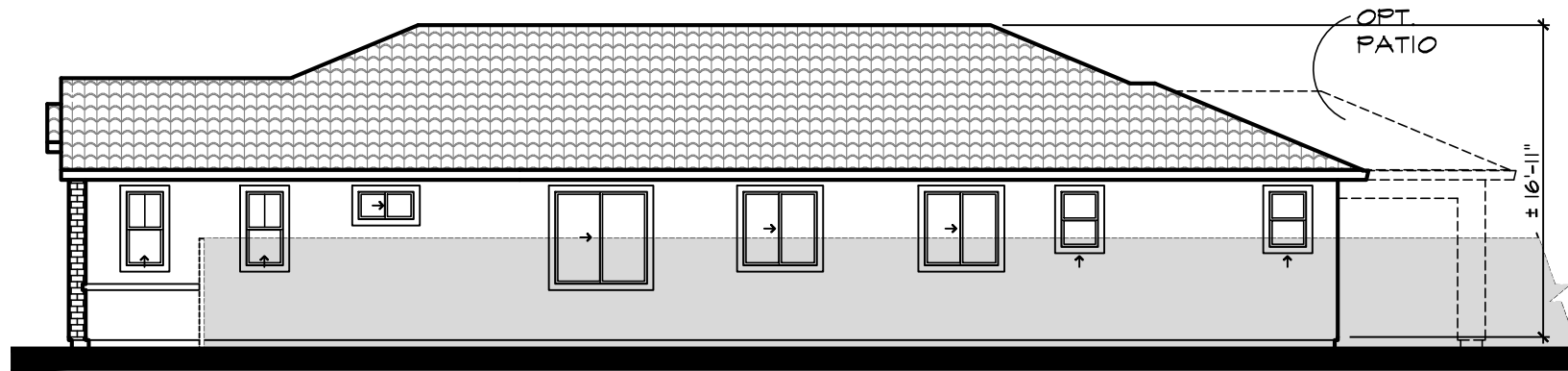

Right



Front - Tuscan

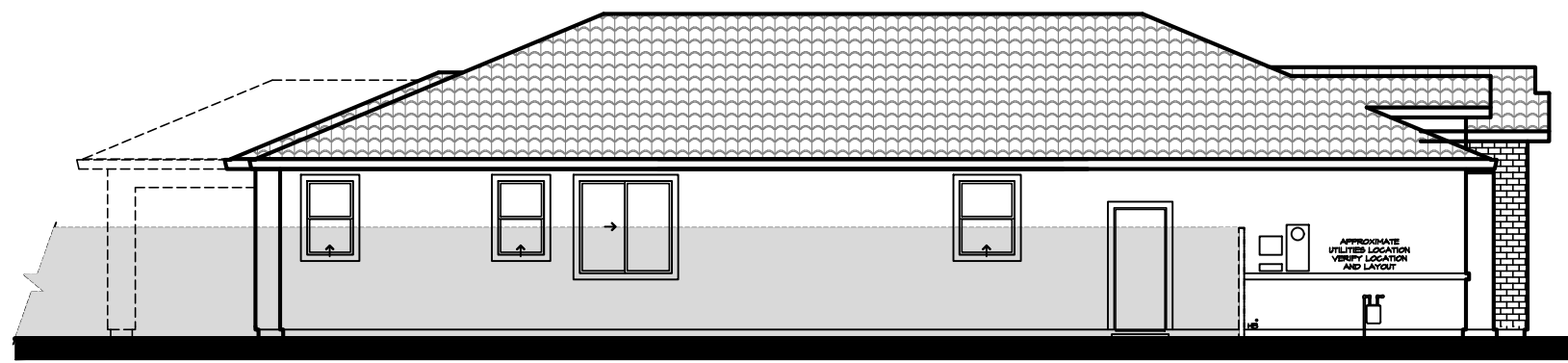
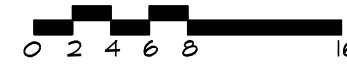

Left

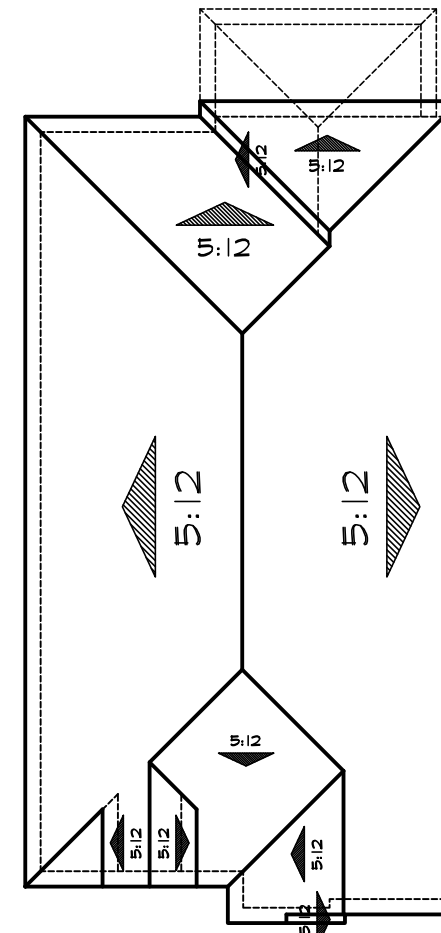

Roof Plan 'A'



Rear

PLAN 2
Elevation A
STONEBROOK

BRENTWOOD, CA

West Coast
HOME BUILDERS

LEGACY
DESIGN GROUP

DATE JULY 01, 2024

2.4

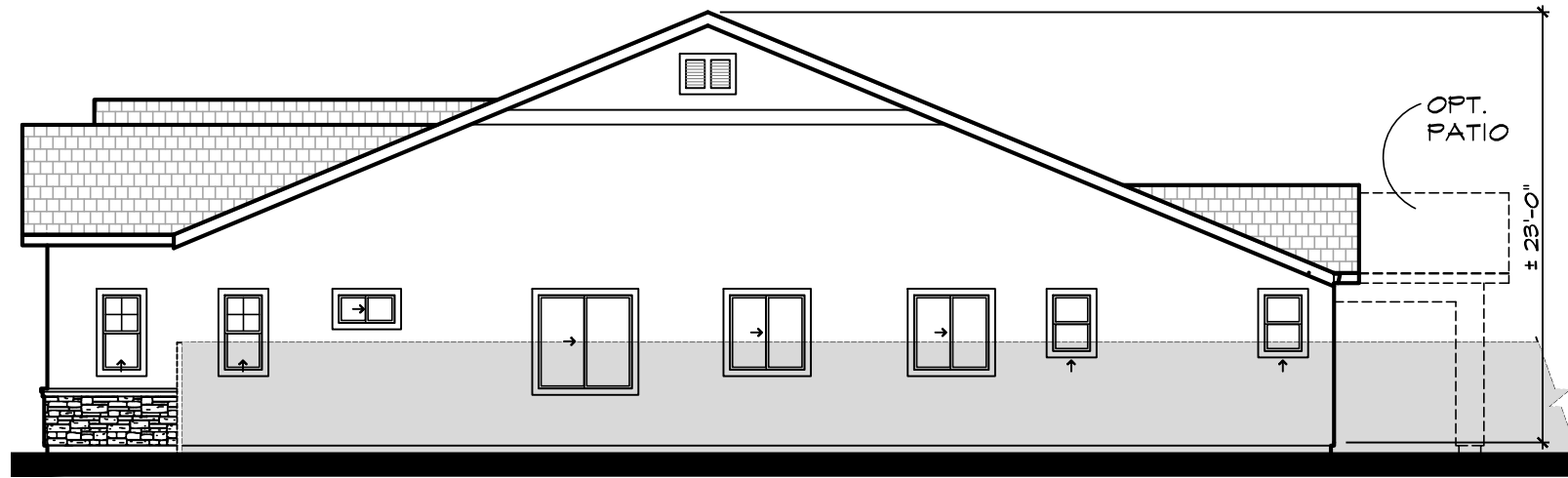

Right



Front - French Cottage

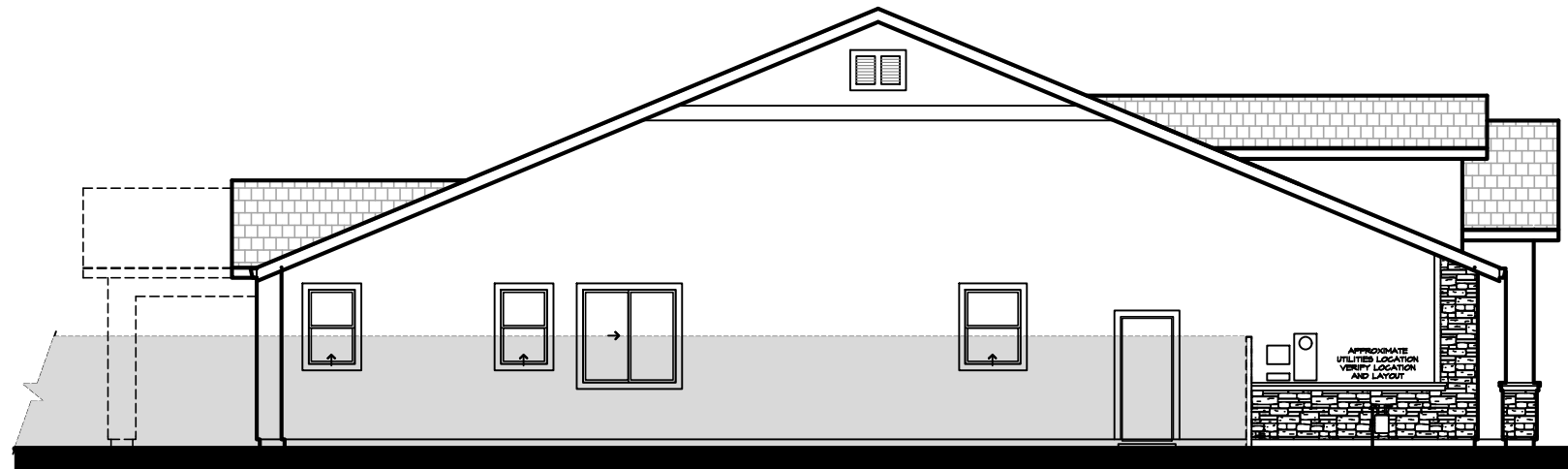
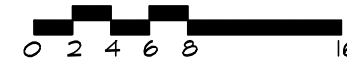

Left

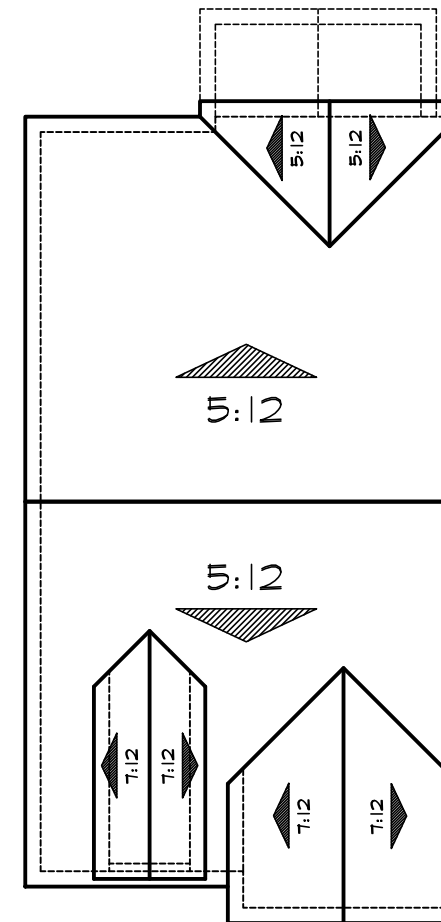

Roof Plan 'B'

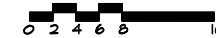

Rear

PLAN 2
Elevation B
STONEBROOK

BRENTWOOD, CA

West Coast
 HOME BUILDERS

LEGACY
 DESIGN GROUP

DATE JULY 01, 2024

2.5

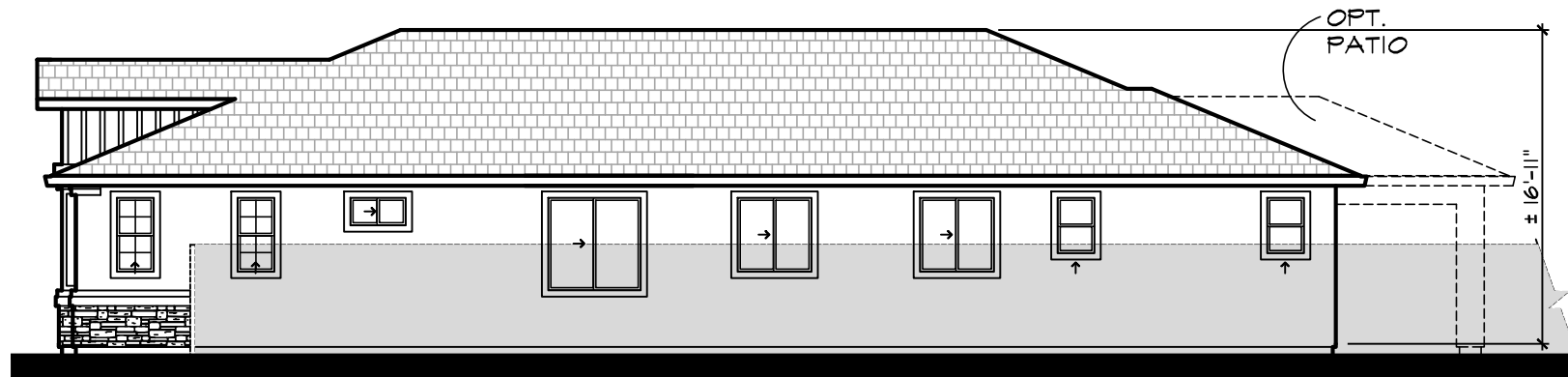

Right



Front - Craftsman

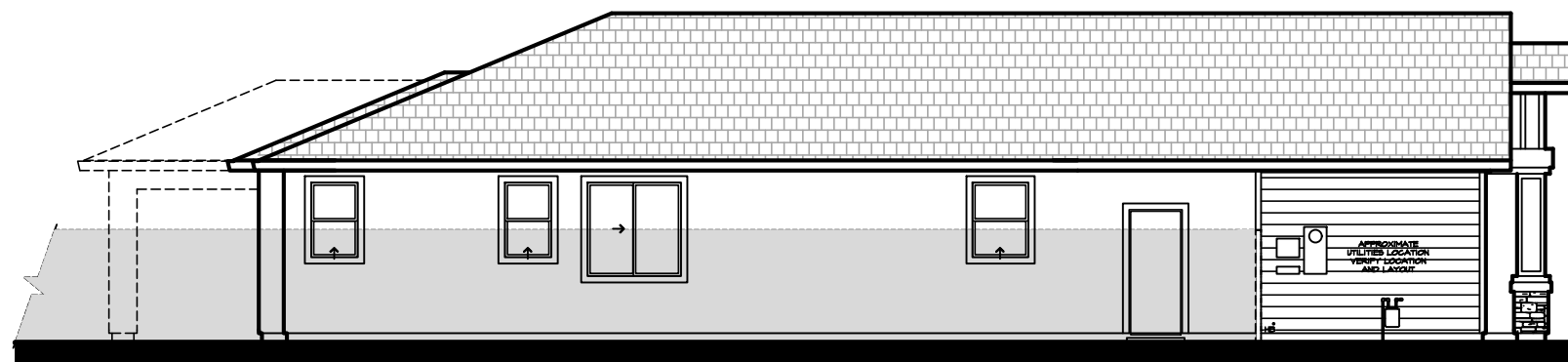
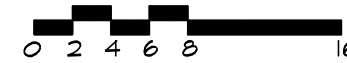

Left

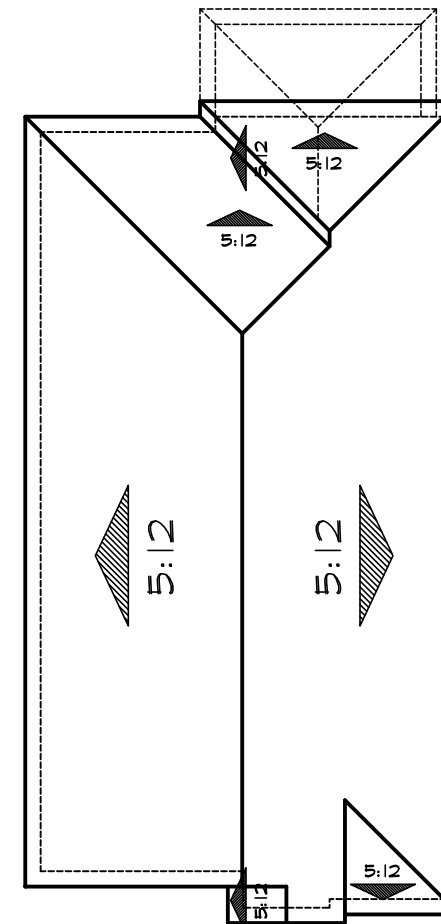

Roof Plan 'C'

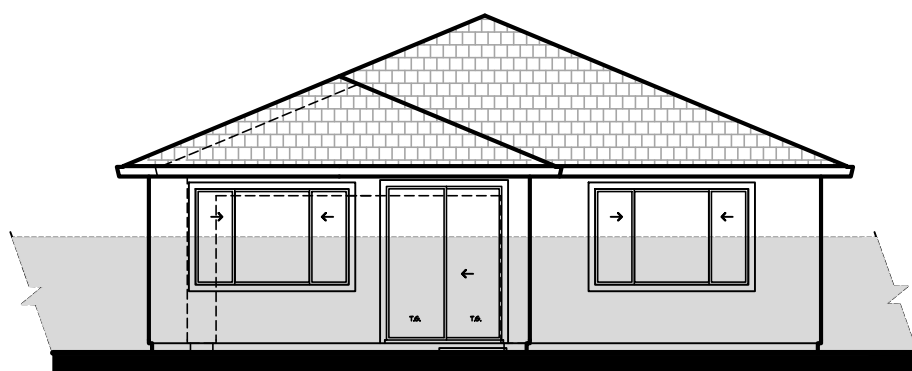

Rear

PLAN 2
Elevation C
STONEBROOK

BRENTWOOD, CA

West Coast
 HOME BUILDERS

LEGACY
DESIGN GROUP

DATE JULY 01, 2024

2.6

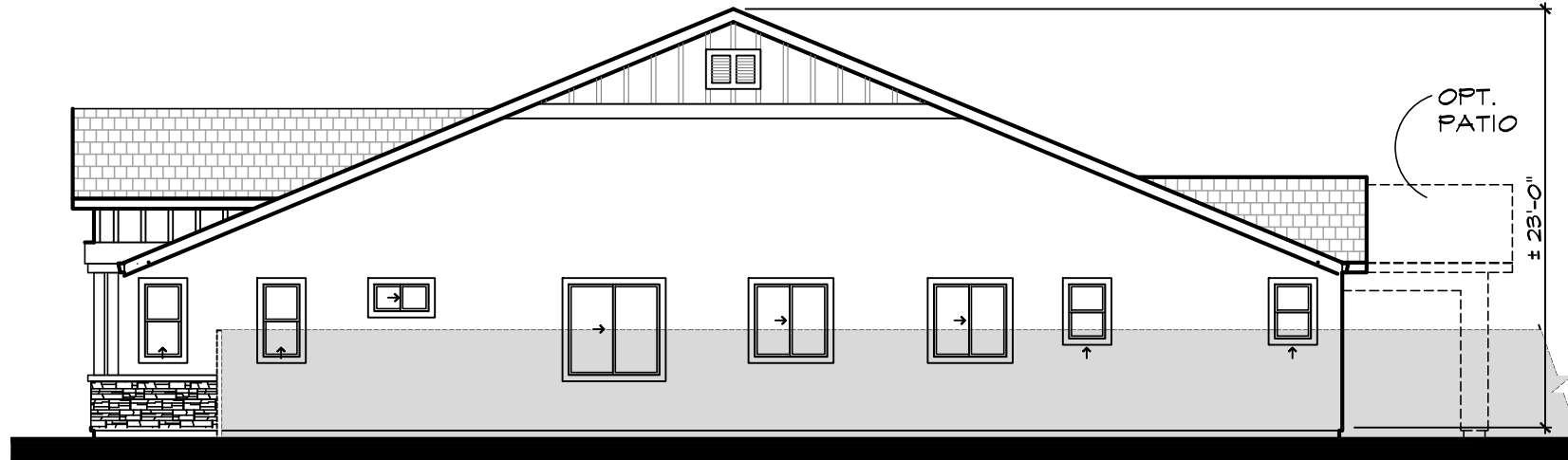

Right



Front - Bay Area Modern

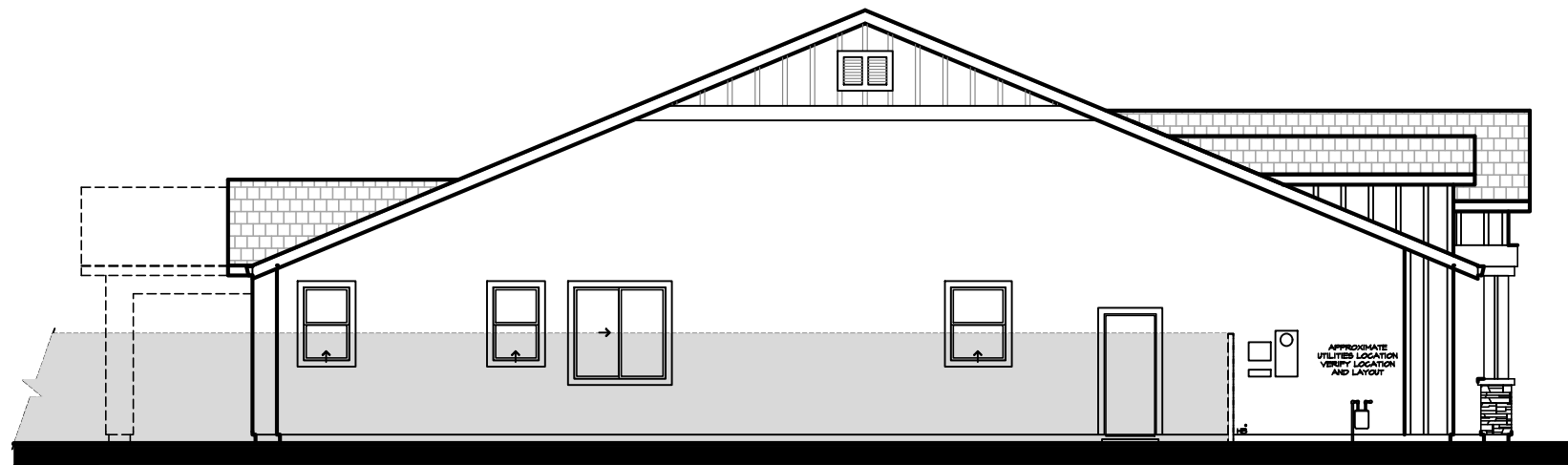
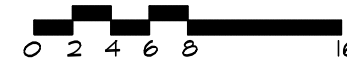

Left

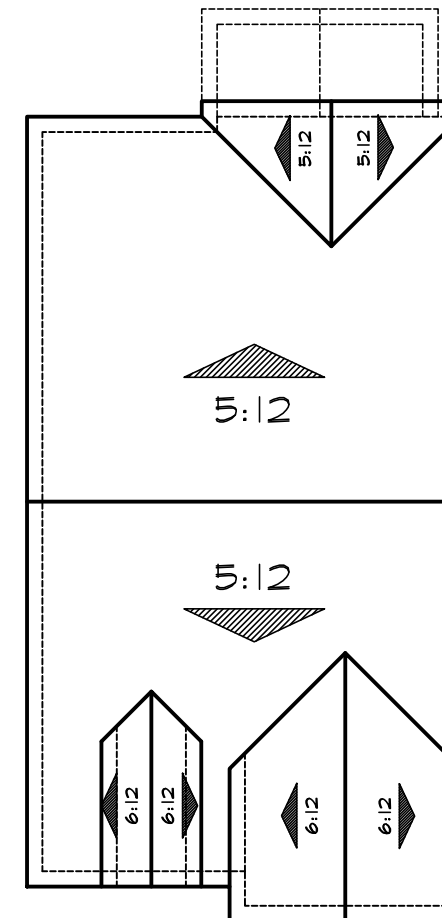

Roof Plan 'D'



Rear

PLAN 2
Elevation D
STONEBROOK

BRENTWOOD, CA

West Coast
 HOME BUILDERS

LEGACY
 DESIGN GROUP

DATE JULY 01, 2024

2.7



Elevation A - Tuscan



Elevation B - French Cottage

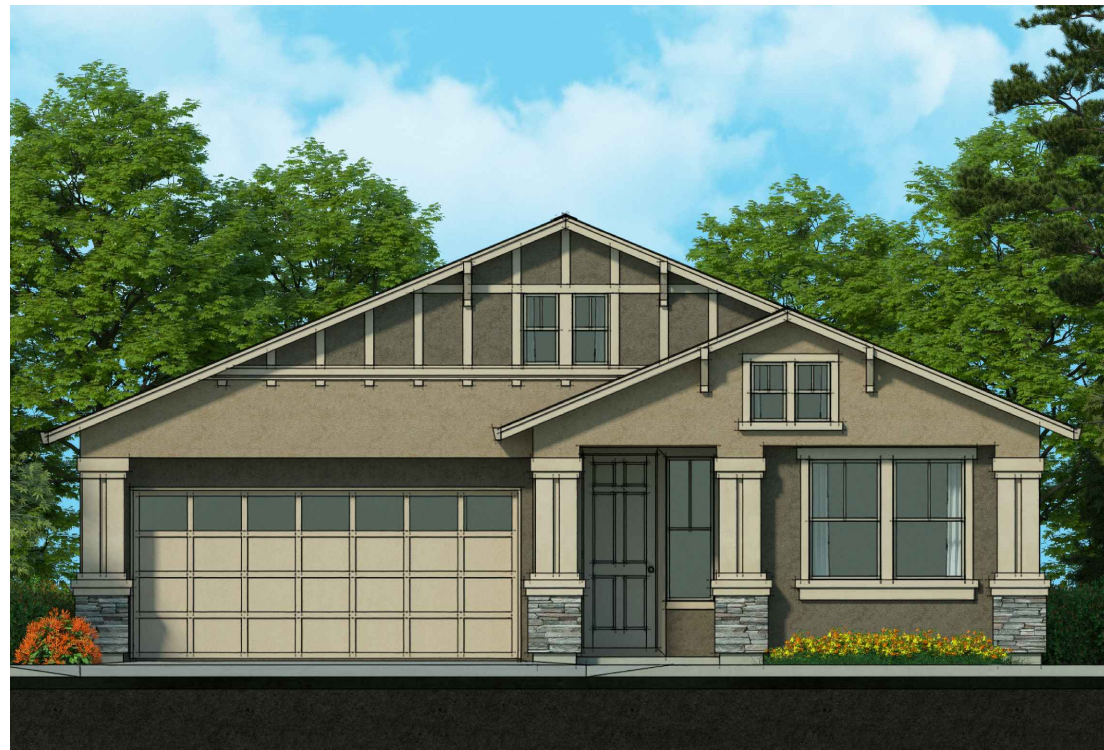

Elevation C - Craftsman

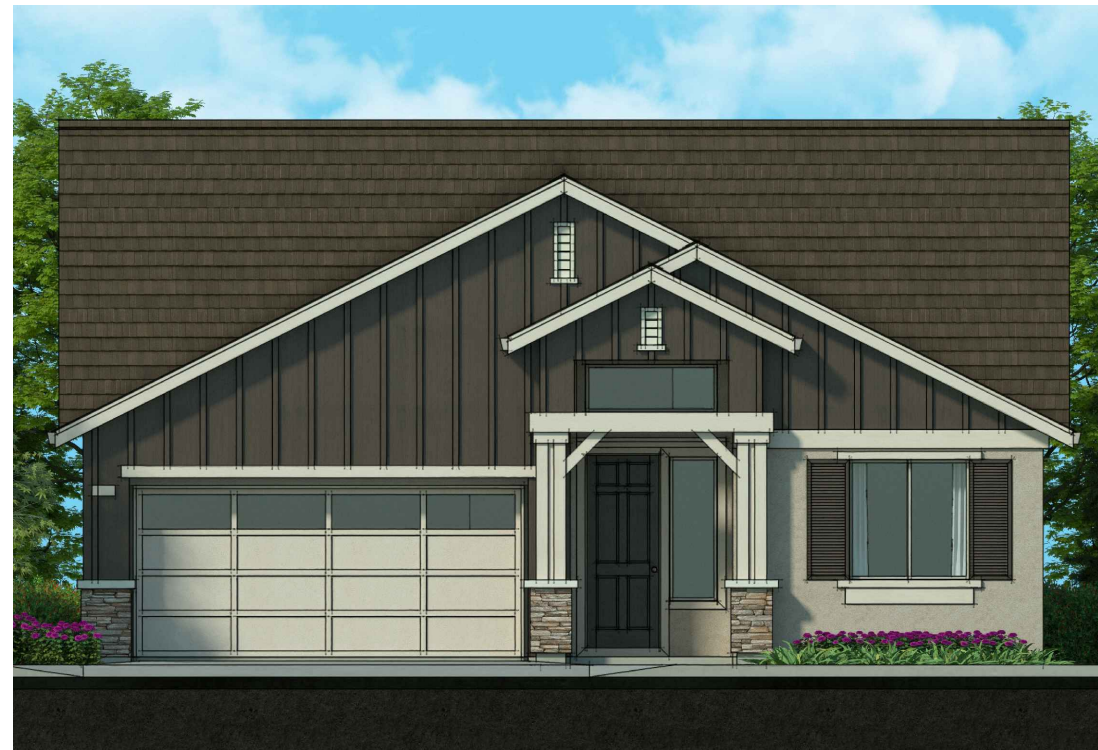

Elevation D - Bay Area Modern

MATERIAL LEGEND

- | | |
|--|---|
| <p>A VILLA CONCRETE TILE ROOFING
 GABLE ROOFS
 STUCCO BODY
 STUCCO/FOAM TRIM
 SIMULATED BRICK VENEER
 STUCCO/FOAM CORBELS
 DECORATIVE WROUGHT IRON
 DECORATIVE FOAM
 ROLL-UP GARAGE DOORS
 W/ OPT. WINDOW LITES</p> | <p>B FLAT CONCRETE TILE ROOFING
 HIP & GABLE ROOFS
 STUCCO BODY
 STUCCO/FOAM TRIM
 MOCK VENTS
 DECORATIVE FOAM
 SIMULATED STONE VENEER
 ROLL-UP GARAGE DOORS
 W/ OPT. WINDOW LITES</p> |
| <p>C FLAT CONCRETE TILE ROOFING
 GABLE ROOFS
 STUCCO BODY
 STUCCO/FOAM TRIM
 SIMULATED STONE VENEER
 STUCCO/FOAM CORBELS
 DECORATIVE FOAM
 ROLL-UP GARAGE DOORS
 W/ OPT. WINDOW LITES</p> | <p>D FLAT CONCRETE TILE ROOFING
 GABLE ROOFS
 STUCCO BODY
 STUCCO/FOAM TRIM
 BOARD & BATTEN
 MOCK VENTS
 SIMULATED STONE VENEER
 MOCK WOOD SHUTTERS
 WOOD KICKERS
 DECORATIVE FOAM
 ROLL-UP GARAGE DOORS
 W/ OPT. WINDOW LITES</p> |

PLAN 3
Front Elevations
STONEBROOK

BRENTWOOD, CA

West Coast
HOME BUILDERS

LEGACY
DESIGN GROUP

DATE JULY 01, 2024

3.1

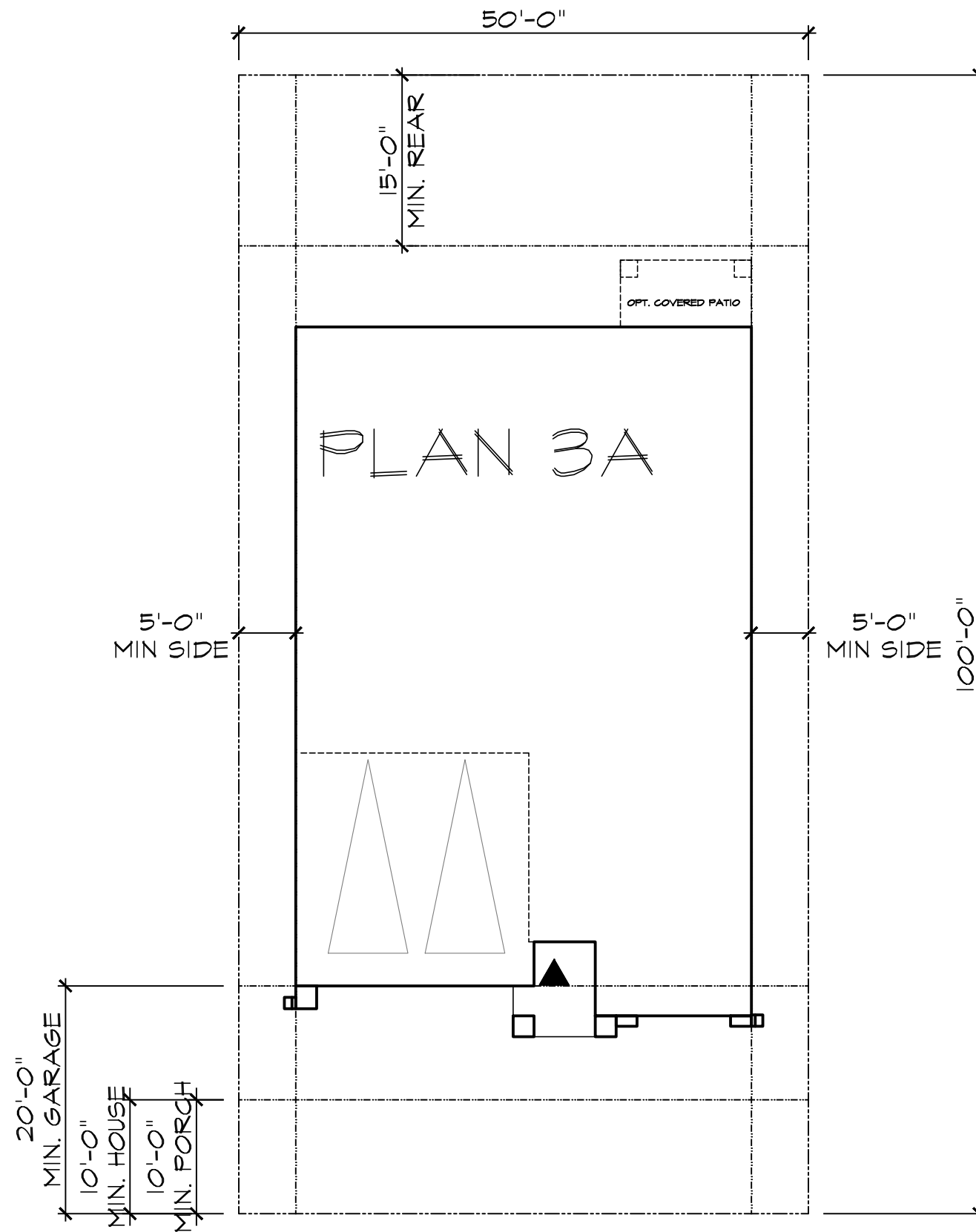

City of Brentwood
MINIMUM REQUIREMENTS

FRONT SETBACK - TO LIVING	10' MIN.
FRONT SETBACK - TO GARAGE	20' MIN.
SIDE YARD - SETBACK	5' MIN.
REAR YARD - SETBACK	15' MIN.
PORCH SETBACK	10' MIN.
LOT SIZE	4,500 SQ. FT.
MAX COVERAGE - 1-STORY	50%

LOT COVERAGE
1-STORY: 50% max

TYPICAL LOT SIZES	FOOTPRINT	APPROX. COVERAGE
50' x 100' = 5,000 SQ. FT.	2,392 SQ. FT.	48%

0 2 4 6 8 16

PLAN 3

Site Plan

STONEBROOK

BRENTWOOD, CA

West Coast
HOME BUILDERS

LEGACY
DESIGN GROUP

DATE JULY 01, 2024

3.2

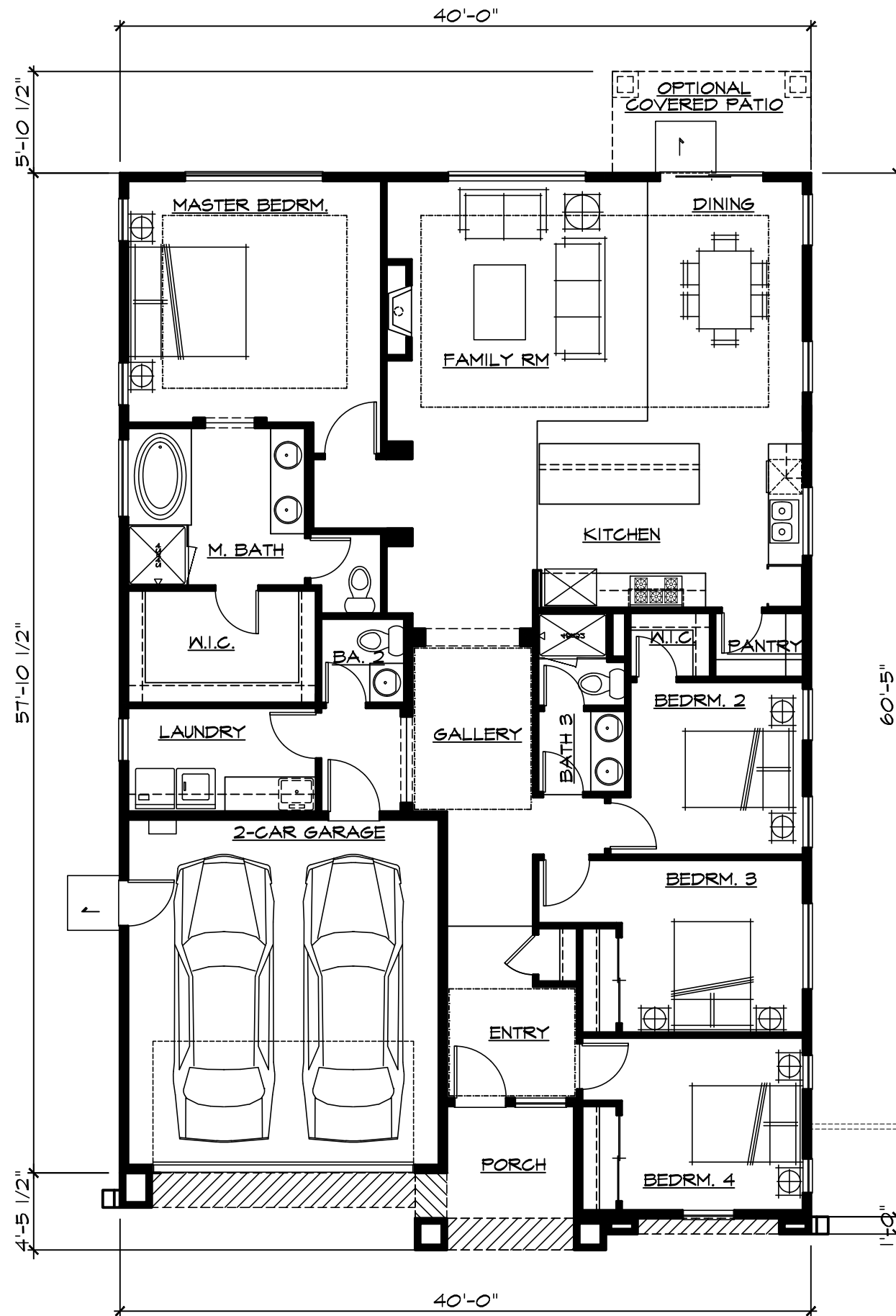

SQUARE FOOTAGE	
FIRST FLOOR	1943 SF
TOTAL LIVING AREA	1943 SF
GARAGE	379 SF
PORCH	70 SF
OPT. REAR PATIO	68 SF
FOOTPRINT	2392 SF

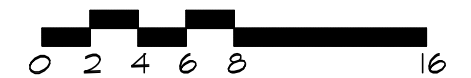

PLAN 3

Floor Plan

STONEBROOK

BRENTWOOD, CA

West Coast
HOME BUILDERS

LEGACY
DESIGN GROUP

DATE JULY 01, 2024

3.3

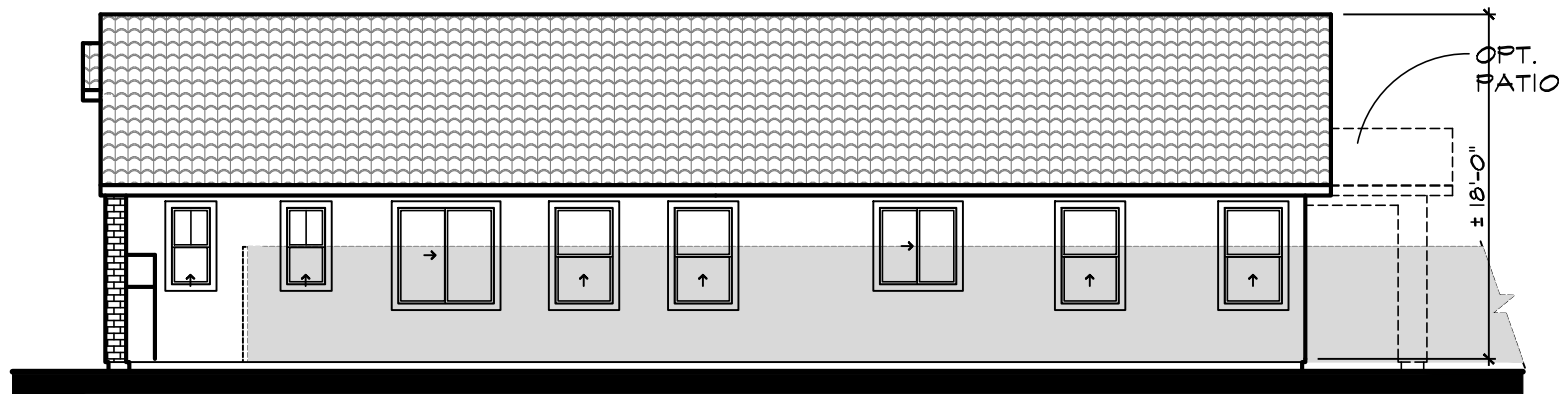

Right



Front - Tuscan

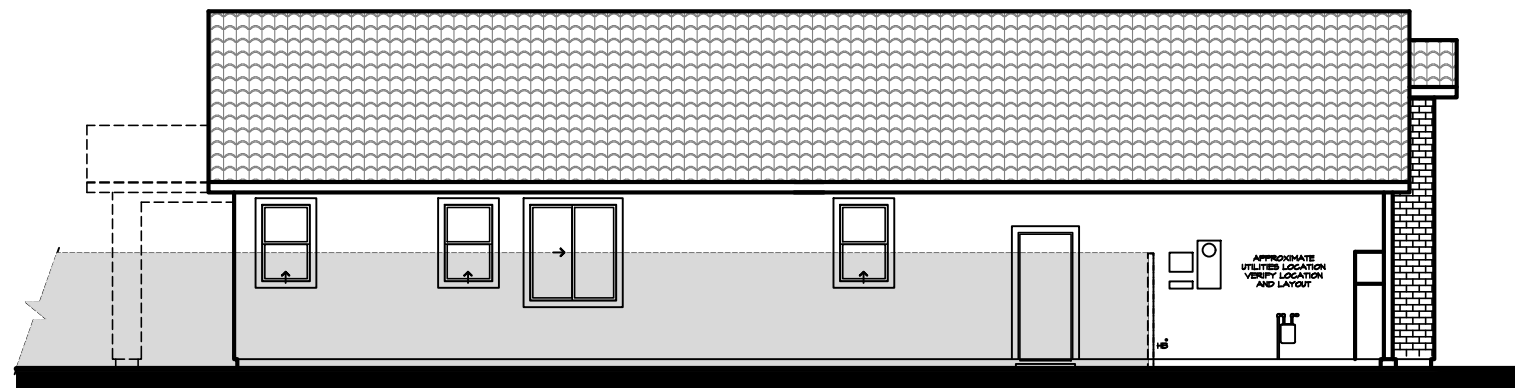
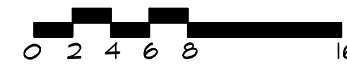

Left

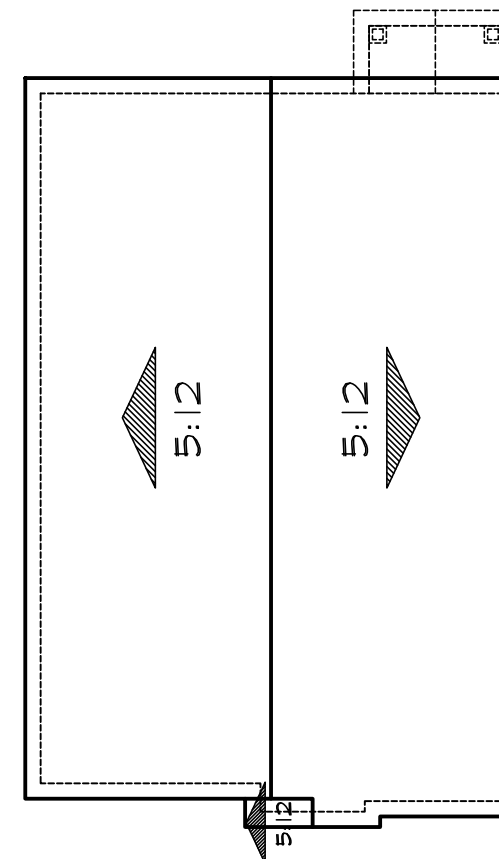

Roof Plan 'A'

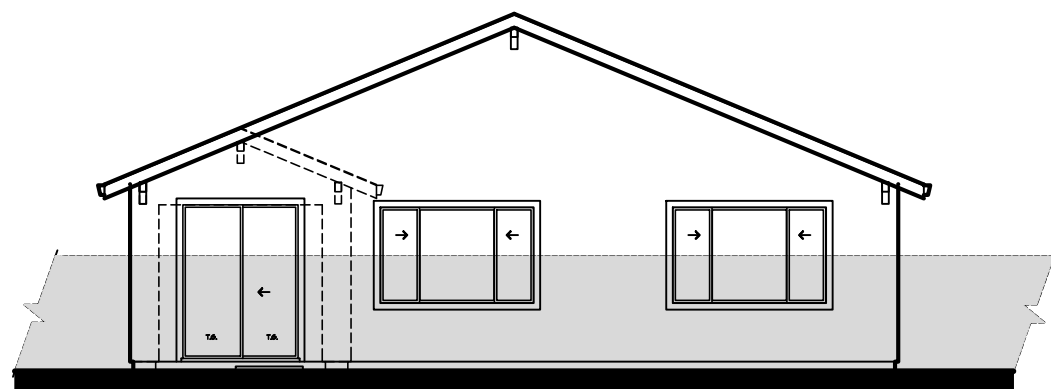

Rear

PLAN 3
Elevation A
STONEBROOK

BRENTWOOD, CA

West Coast
 HOME BUILDERS

LEGACY
 DESIGN GROUP

DATE JULY 01, 2024

3.4

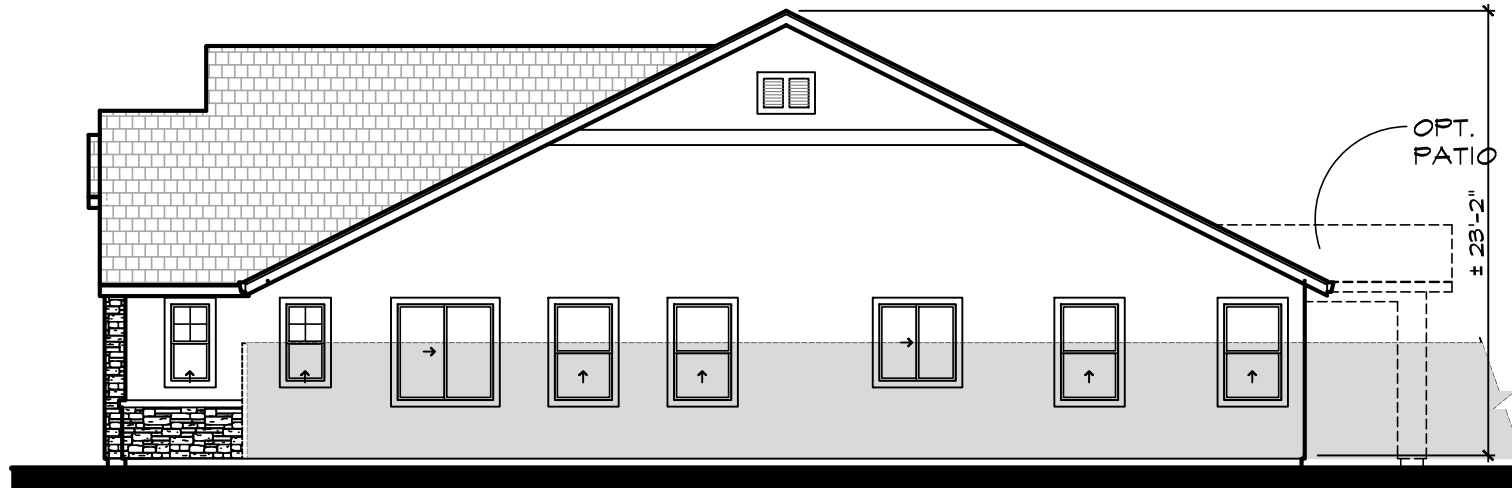

Right



Front - French Cottage

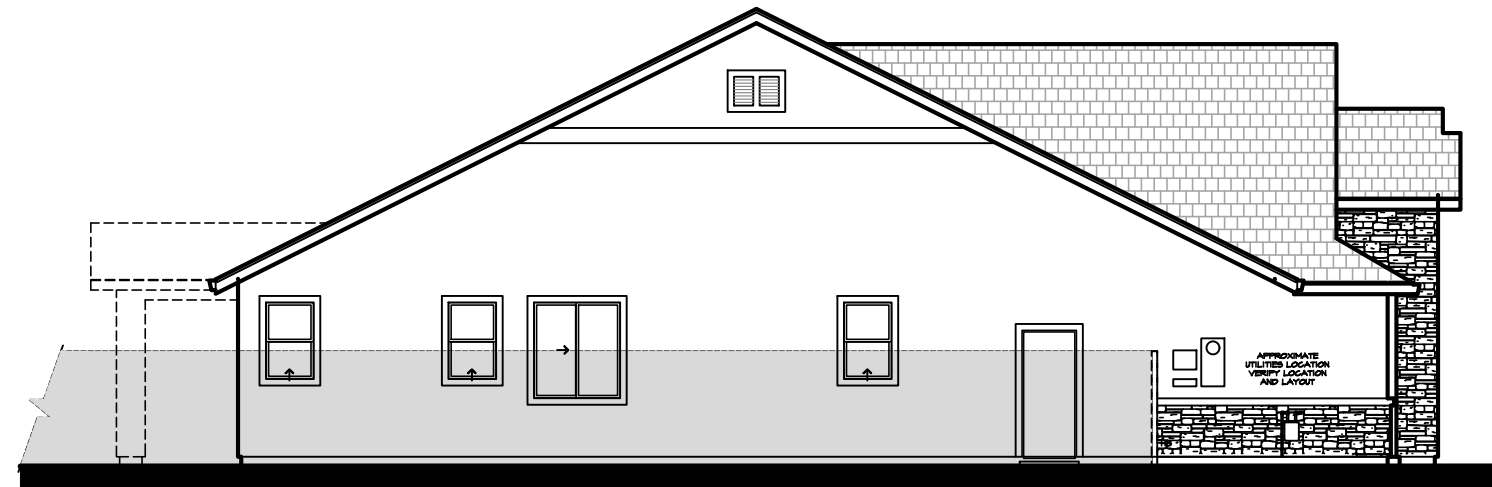
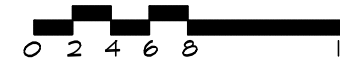

Left

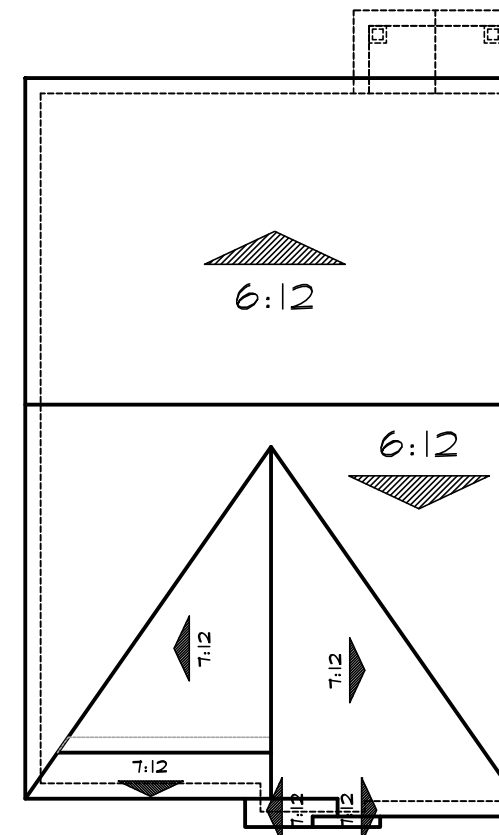

Roof Plan 'B'

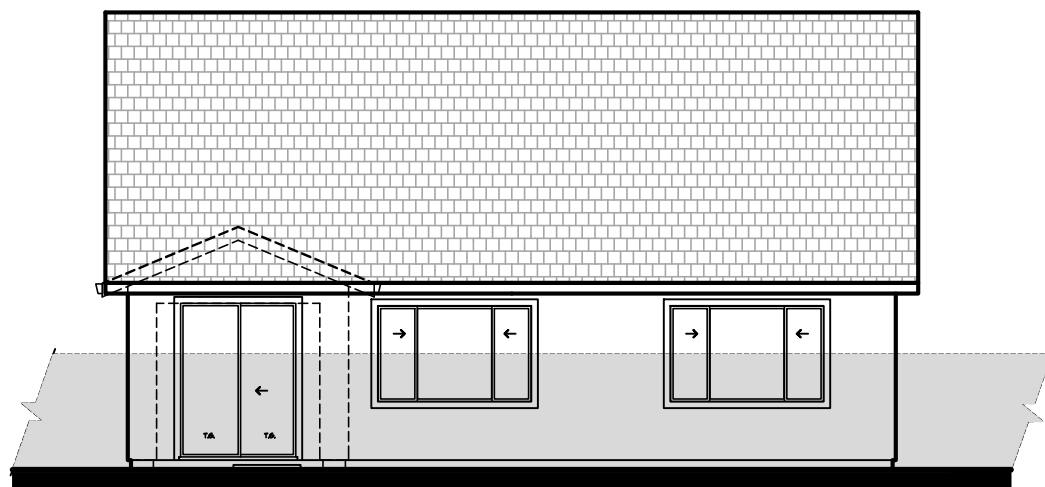

Rear

PLAN 3
Elevation B
STONEBROOK

BRENTWOOD, CA

West Coast
HOME BUILDERS

LEGACY
DESIGN GROUP

DATE JULY 01, 2024

3.5

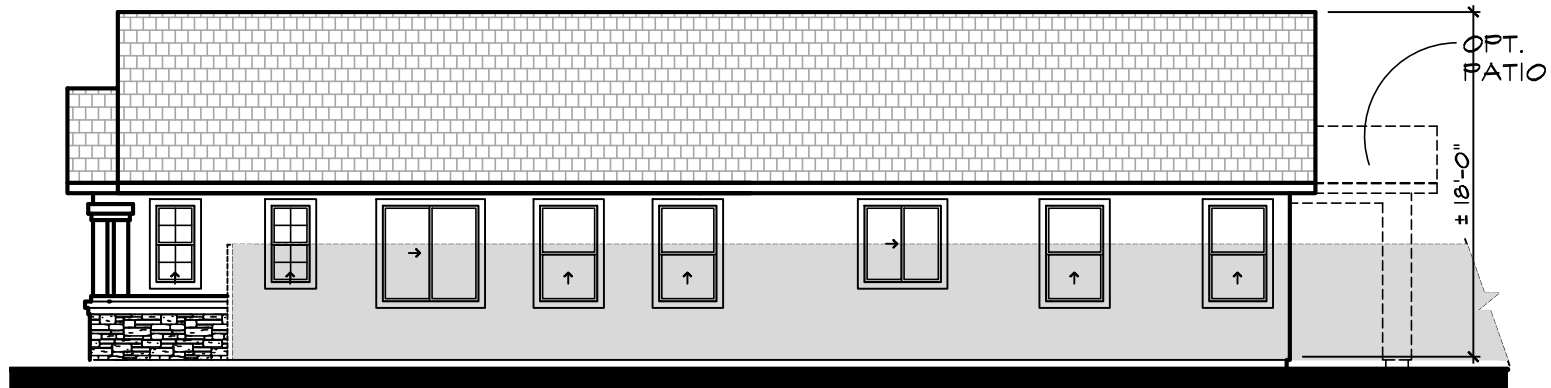

Right



Front - Craftsman

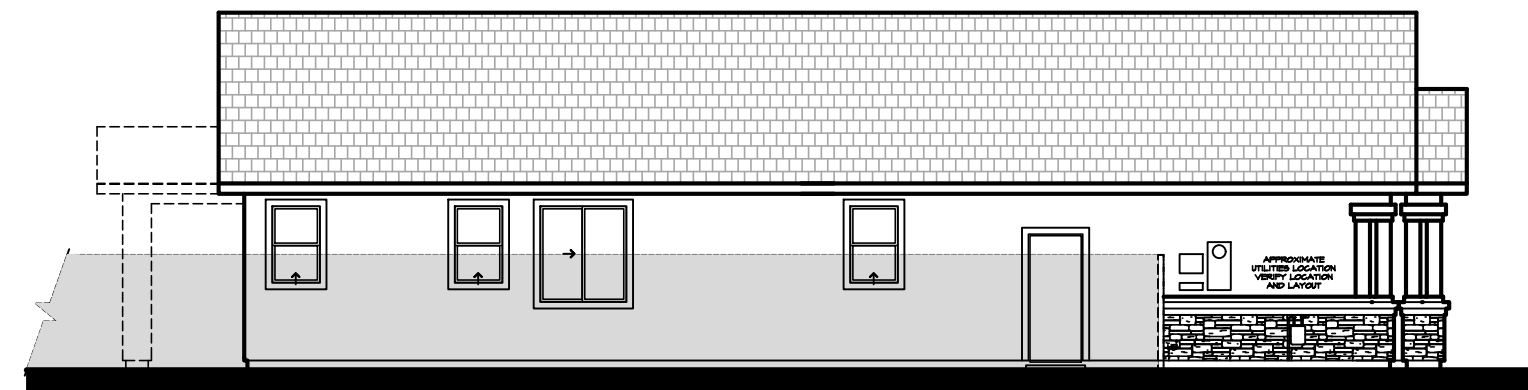
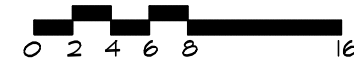

Left

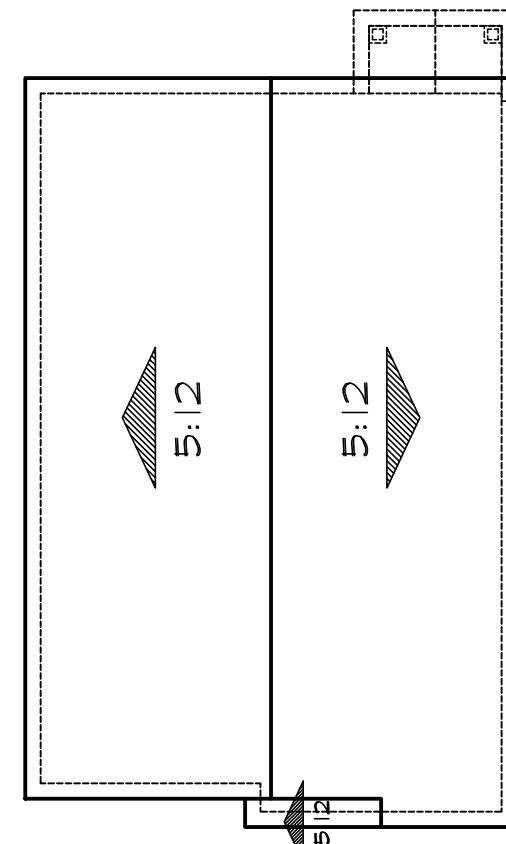

Roof Plan 'C'

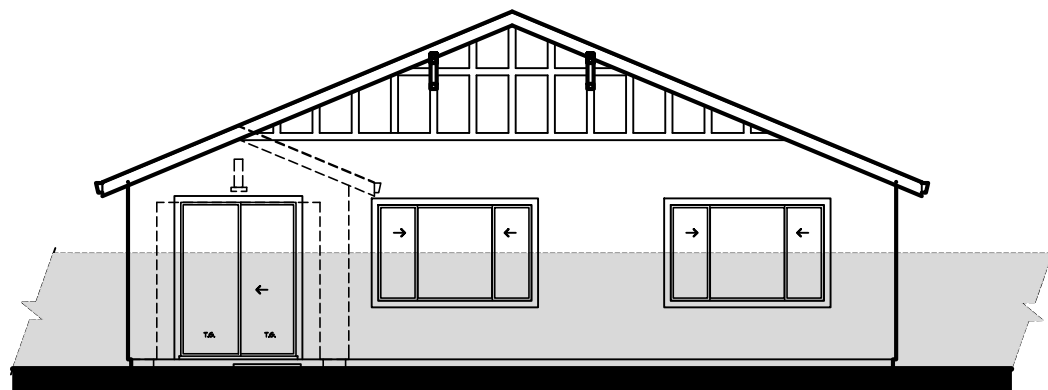

Rear

PLAN 3
Elevation C
STONEBROOK

BRENTWOOD, CA

West Coast
HOME BUILDERS

LEGACY
DESIGN GROUP

DATE JULY 01, 2024

3.6

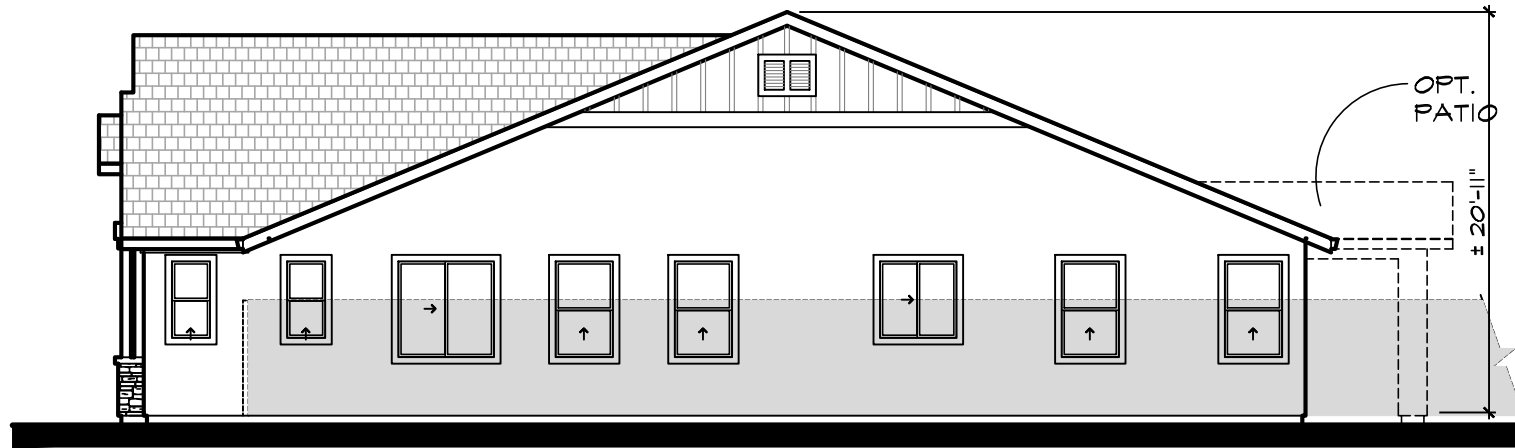

Right



Front - Bay Area Modern

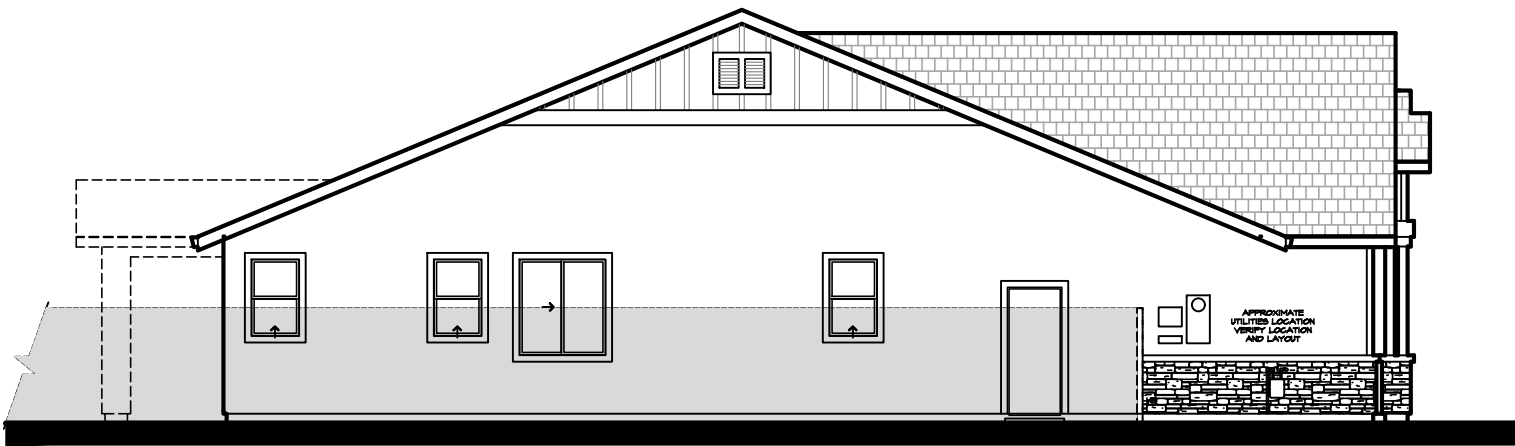
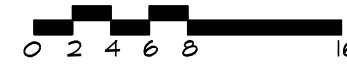

Left

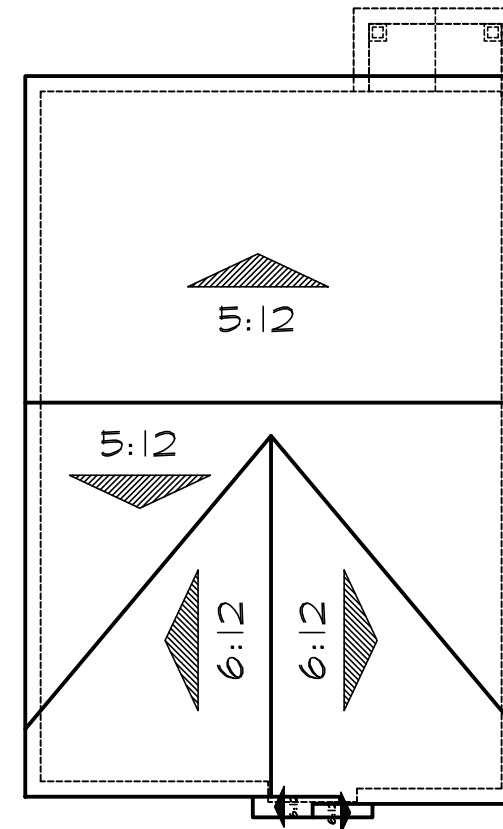

Roof Plan 'D'

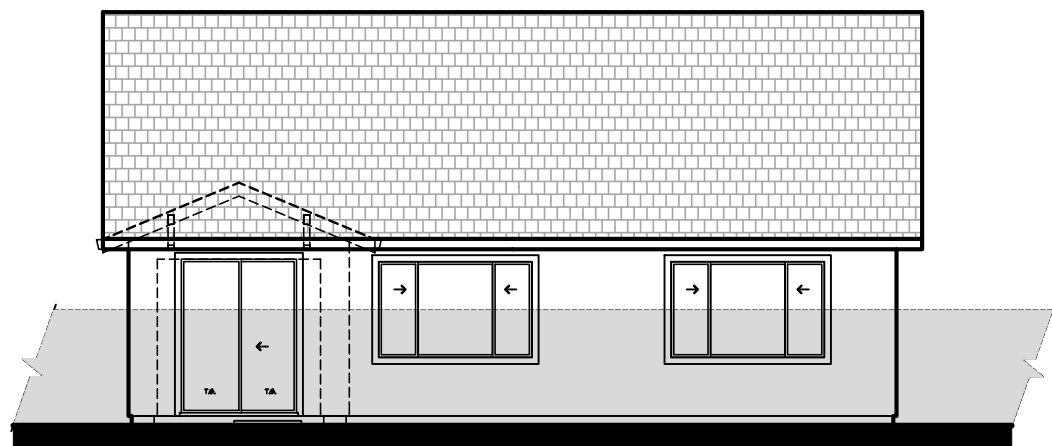
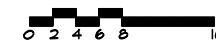

Rear

PLAN 3
Elevation D
STONEBROOK

BRENTWOOD, CA

West Coast
 HOME BUILDERS

LEGACY
 DESIGN GROUP

DATE JULY 01, 2024

3.7



Elevation A - Tuscan



Elevation B - French Cottage

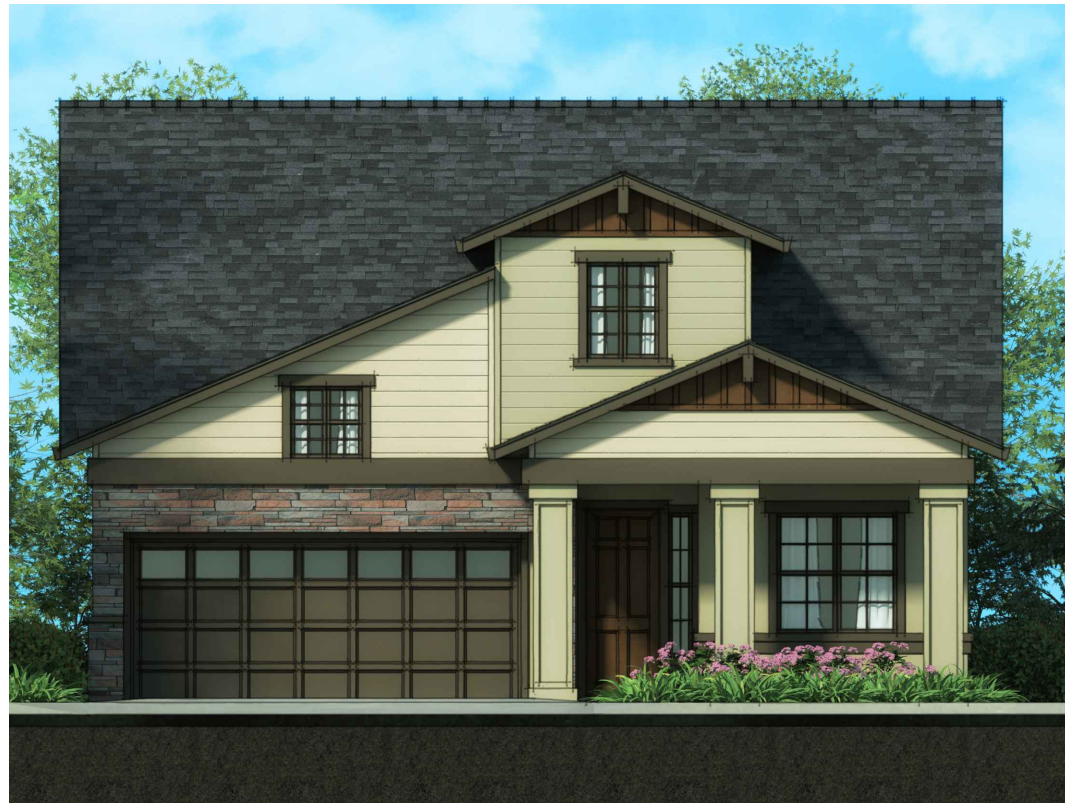

Elevation C - Craftsman



Elevation D - Bay Area Modern

MATERIAL LEGEND

- | | |
|--|---|
| <p>A VILLA CONCRETE TILE ROOFING
 GABLE ROOFS
 STUCCO BODY
 STUCCO/FOAM TRIM
 SIMULATED BRICK VENEER
 DECORATIVE FOAM
 STUCCO/FOAM CORBELS
 DECORATIVE WROUGHT IRON
 ROLL-UP GARAGE DOORS
 W/ OPT. WINDOW LITES</p> | <p>B FLAT CONCRETE TILE ROOFING
 GABLE ROOFS
 STUCCO BODY
 STUCCO/FOAM TRIM
 MOCK VENTS
 DECORATIVE FOAM
 SIMULATED STONE VENEER
 ROLL-UP GARAGE DOORS
 W/ OPT. WINDOW LITES</p> |
| <p>C FLAT CONCRETE TILE ROOFING
 GABLE ROOFS
 STUCCO BODY
 STUCCO/FOAM TRIM
 LAP SIDING
 DECORATIVE FOAM
 SIMULATED STONE VENEER
 STUCCO/FOAM CORBELS
 BOARD & BATTEN
 WOOD RAILING
 ROLL-UP GARAGE DOORS
 W/ OPT. WINDOW LITES</p> | <p>D FLAT CONCRETE TILE ROOFING
 GABLE ROOFS
 STUCCO BODY
 STUCCO/FOAM TRIM
 BOARD & BATTEN
 MOCK VENTS
 SIMULATED STONE VENEER
 DECORATIVE FOAM
 WOOD KICKERS
 ROLL-UP GARAGE DOORS
 W/ OPT. WINDOW LITES</p> |

PLAN 4
Front Elevations
STONEBROOK

BRENTWOOD, CA

West Coast
HOME BUILDERS

LEGACY
DESIGN GROUP

DATE JULY 01, 2024

4.1

City of Brentwood
MINIMUM REQUIREMENTS

FRONT SETBACK - TO LIVING	10' MIN.
FRONT SETBACK - TO GARAGE	20' MIN.
SIDE YARD - SETBACK	5' MIN.
REAR YARD - SETBACK	15' MIN.
PORCH SETBACK	10' MIN.
LOT SIZE -	4,500 SQ. FT.
MAX COVERAGE - 2-STORY	40%

LOT COVERAGE 2-STORY: 40% max		
TYPICAL LOT SIZES	FOOTPRINT	APPROX. COVERAGE
45' x 100' = 4,500 SQ. FT.	1,810 SQ. FT.	40%

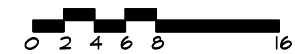
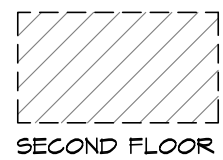
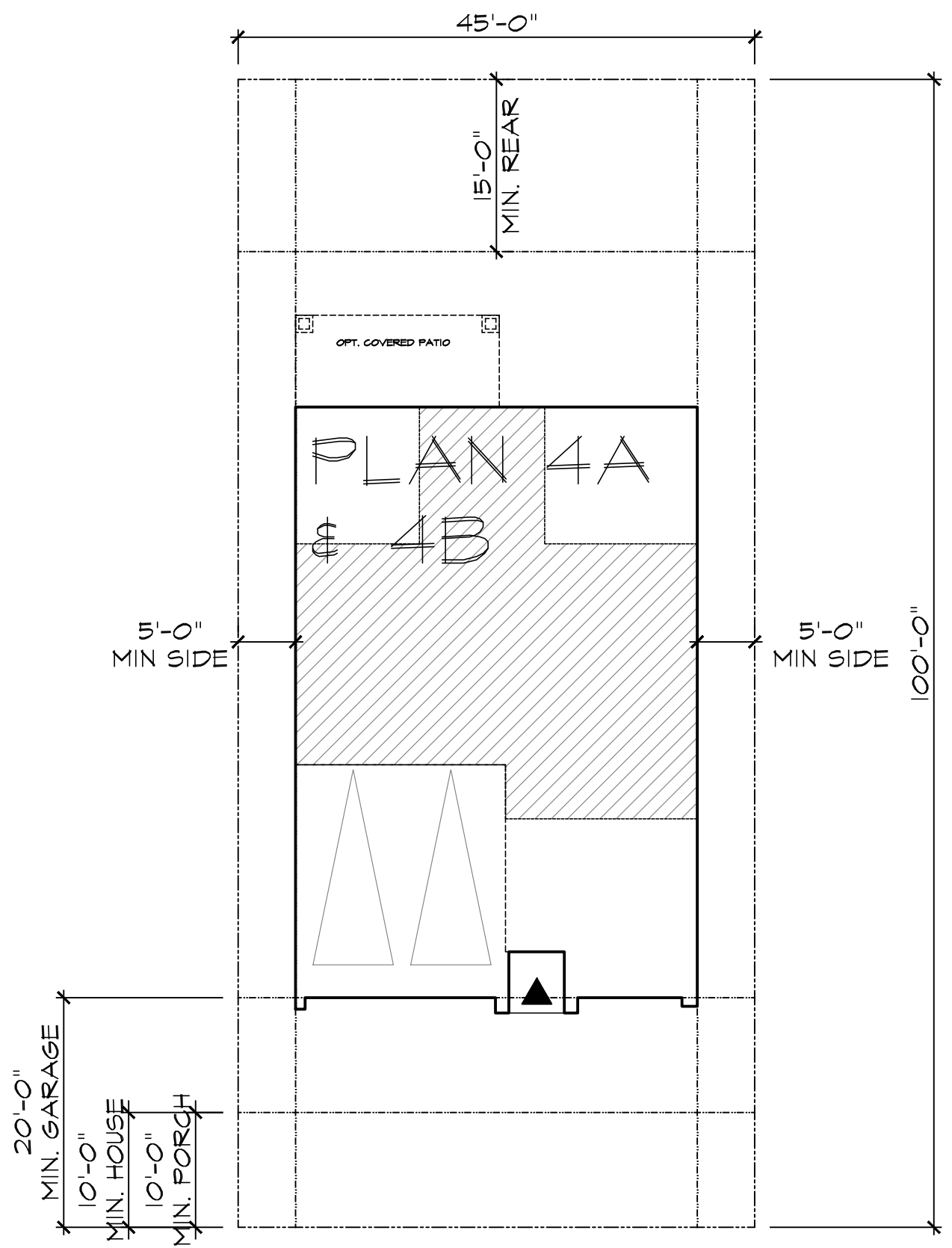

PLAN 4
Site Plan
STONEBROOK
BRENTWOOD, CA

West Coast
HOME BUILDERS
LEGACY
DESIGN GROUP
DATE JULY 01, 2024

4.2

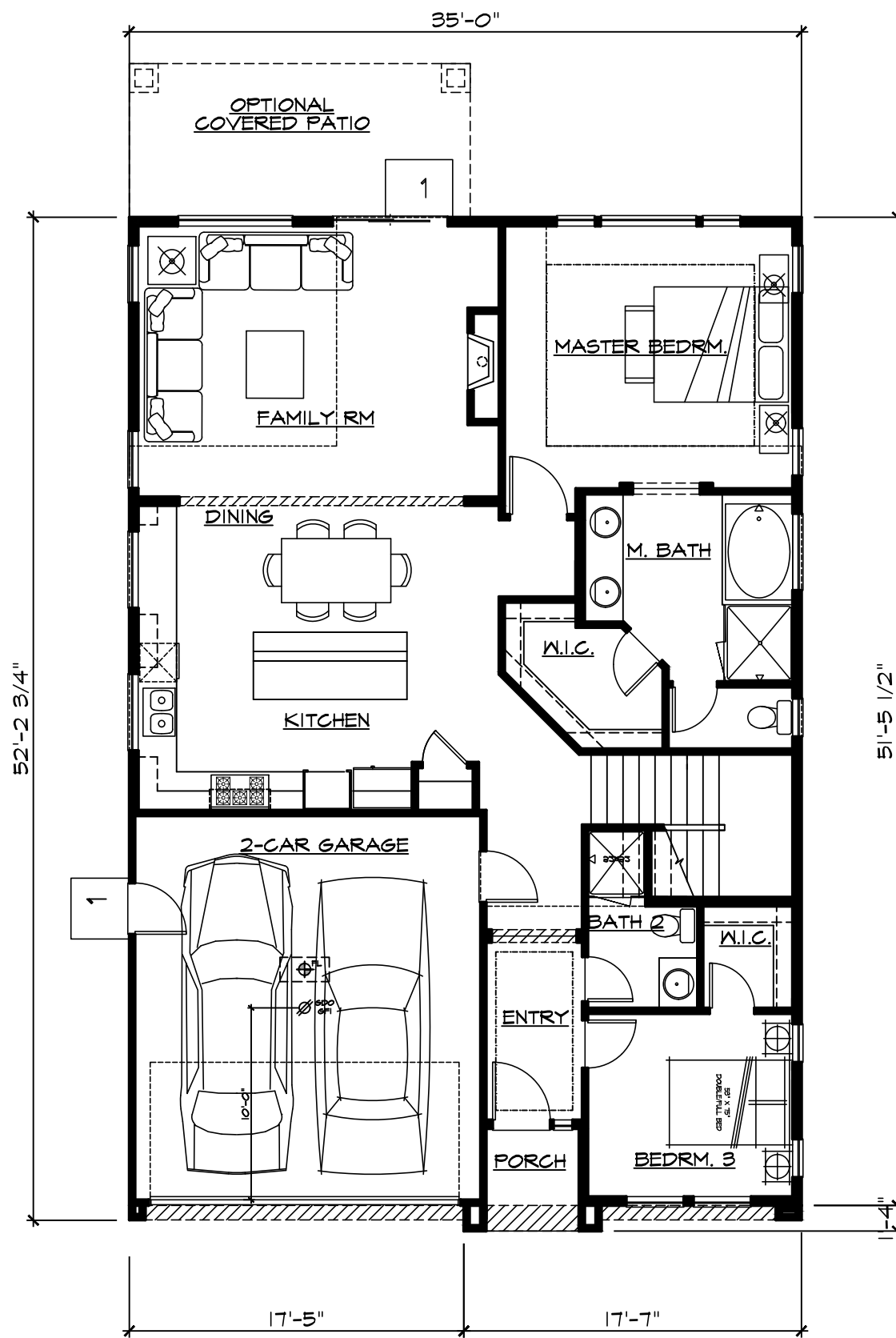

SQUARE FOOTAGE	
FIRST FLOOR	1409 SF
SECOND FLOOR	814 SF
TOTAL LIVING AREA	2223 SF
<hr/>	
GARAGE	372 SF
PORCH	29 SF
OPT. REAR PATIO	142 SF
FOOTPRINT	1810 SF



PLAN 4

First Floor

STONEBROOK

BRENTWOOD, CA

West Coast
HOME BUILDERS

LEGACY
DESIGN GROUP

DATE JULY 01, 2024

4.3

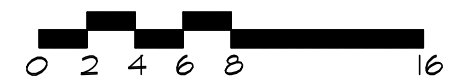
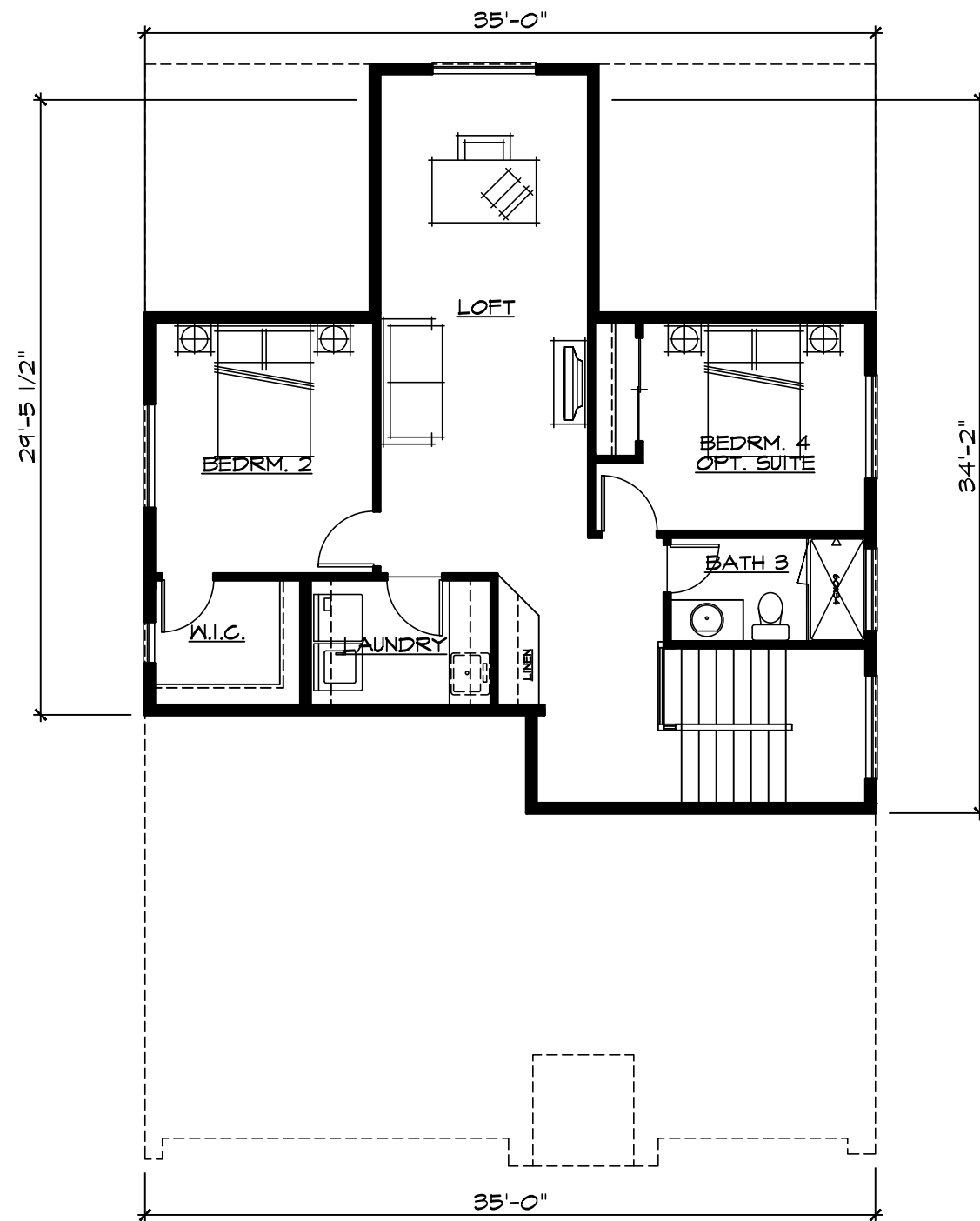

PLAN 4

Second Floor

STONEBROOK

BRENTWOOD, CA

West Coast
HOME BUILDERS

LEGACY
DESIGN GROUP

DATE JULY 01, 2024

4.4



Right



Left

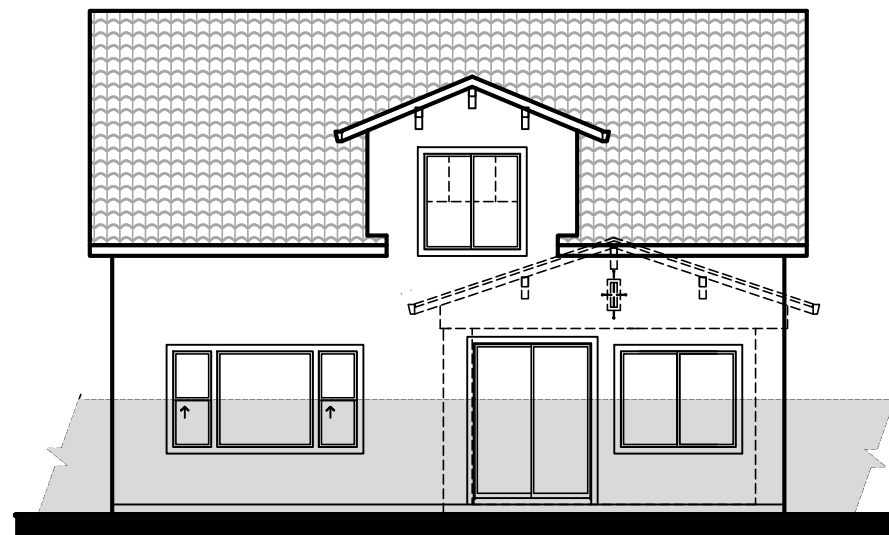

Rear



Front - Tuscan

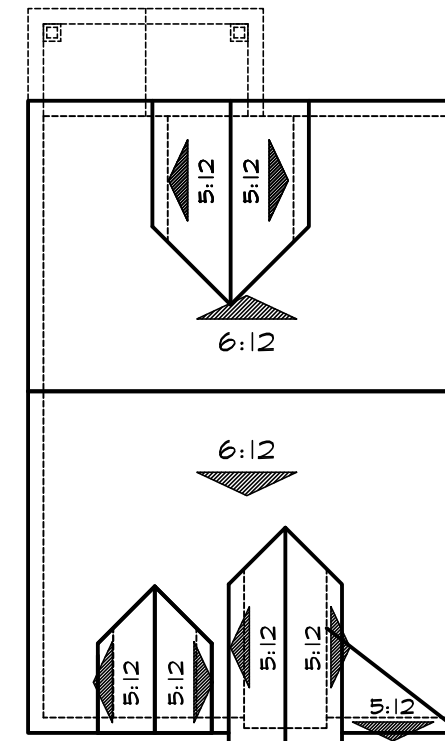

Roof Plan 'A'

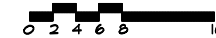

--- DENOTES WINDOW GRIDS & TRIM AT SIDE ELEVATIONS FACING STREETS.

PLAN 4
Elevation A
STONEBROOK

BRENTWOOD, CA

West Coast
 HOME BUILDERS

LEGACY
 DESIGN GROUP

DATE JULY 01, 2024

4.5

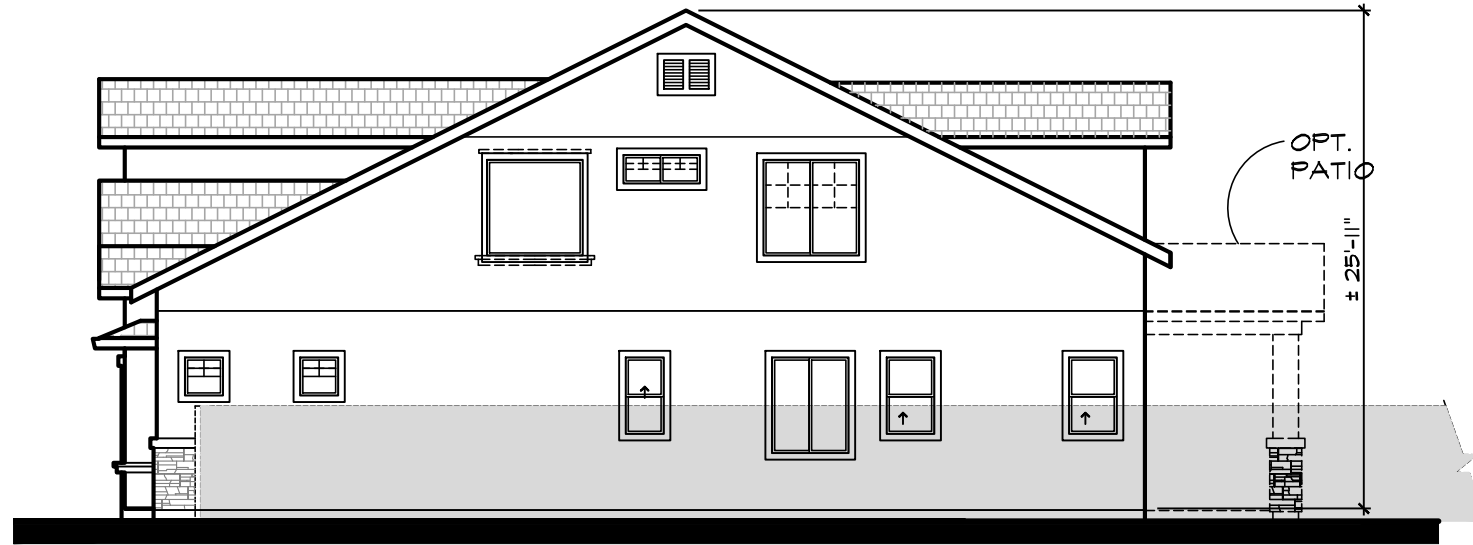

Right



Front - French Cottage



Left

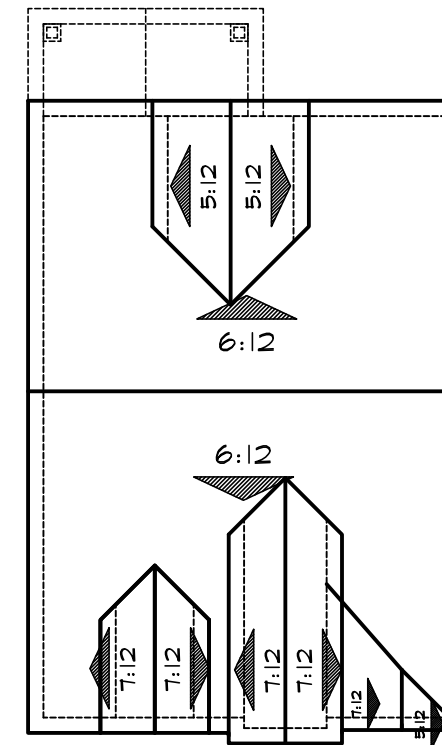

--- DENOTES WINDOW GRIDS & TRIM AT SIDE ELEVATIONS FACING STREETS.



Rear

Roof Plan 'B'



PLAN 4
Elevation B
STONEBROOK

BRENTWOOD, CA

West Coast
 HOME BUILDERS

LEGACY
 DESIGN GROUP

DATE JULY 01, 2024

4.6



Right

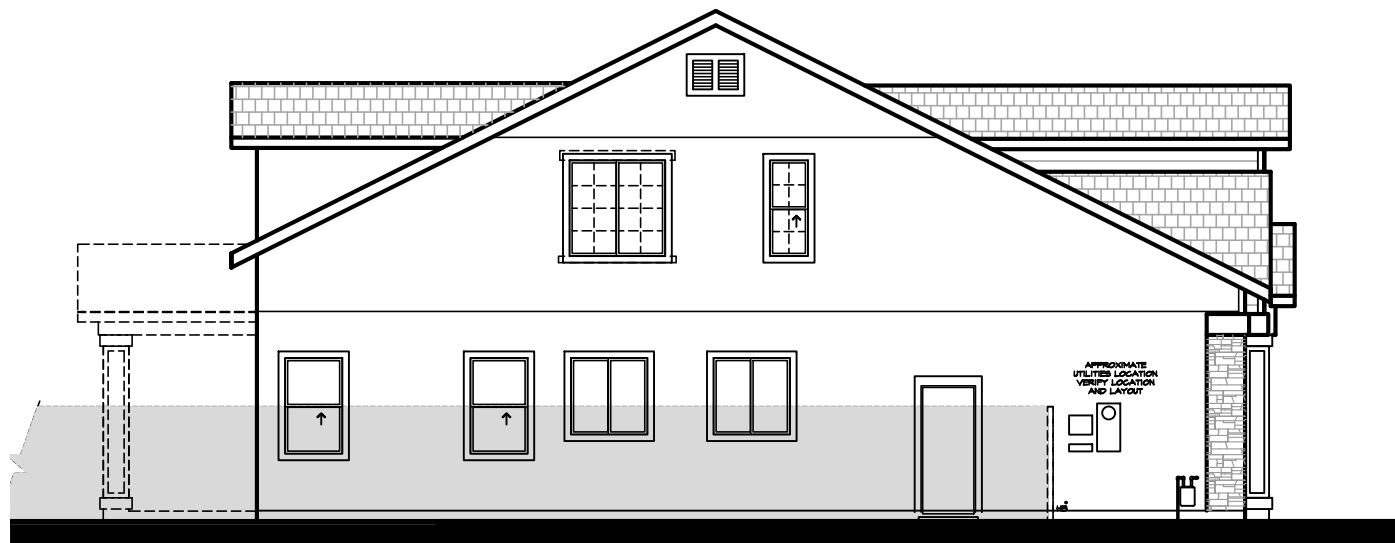

Left



Rear



Front - Craftsman

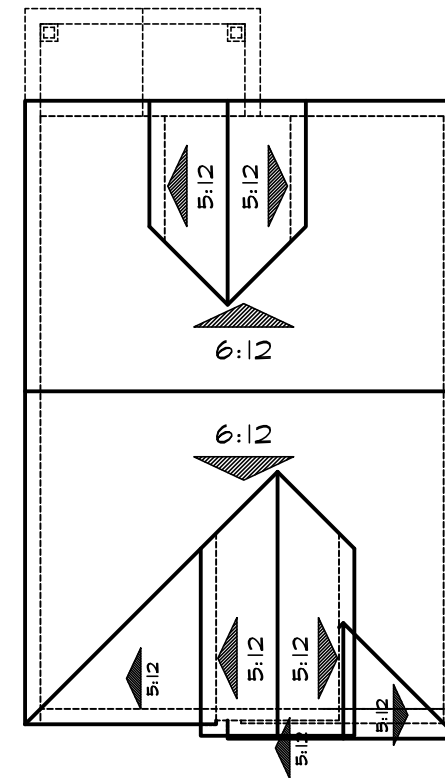

Roof Plan 'C'



--- DENOTES WINDOW GRIDS & TRIM AT SIDE ELEVATIONS FACING STREETS.

PLAN 4
Elevation C
STONEBROOK

BRENTWOOD, CA

West Coast
 HOME BUILDERS

LEGACY
 DESIGN GROUP

DATE JULY 01, 2024

4.7

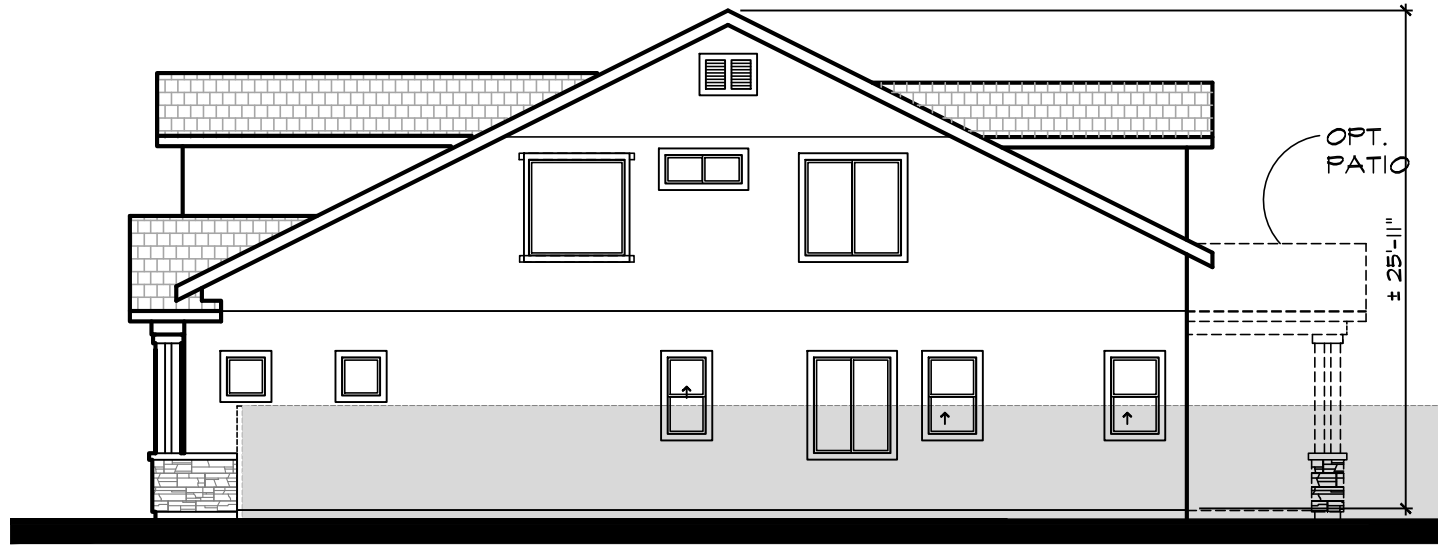

Right

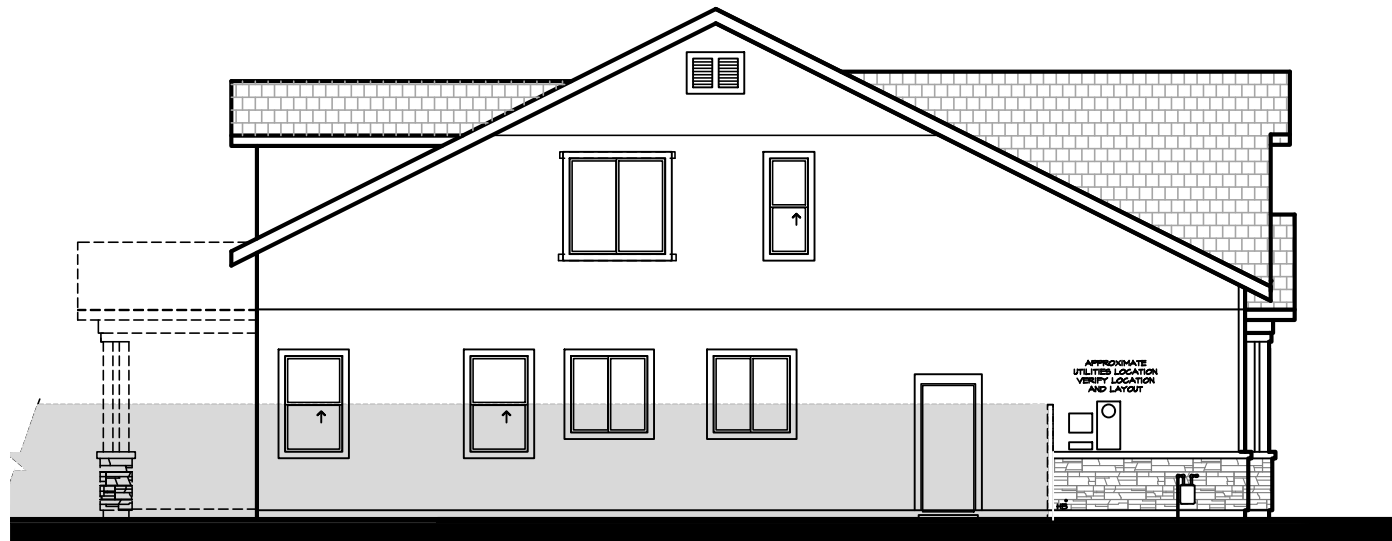

Left



Rear



Front - Bay Area Modern

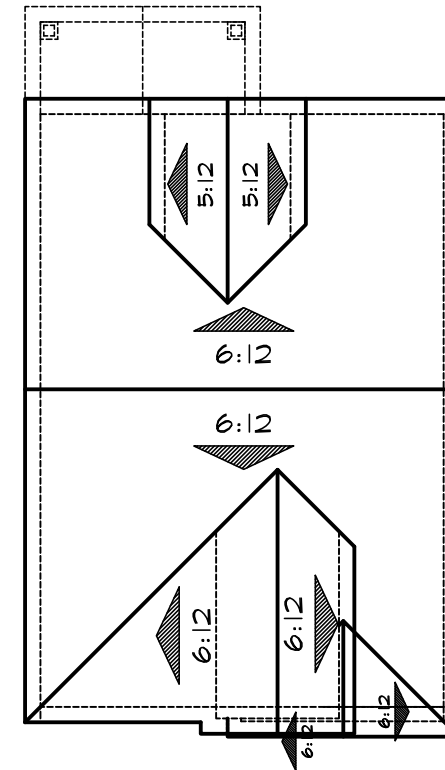
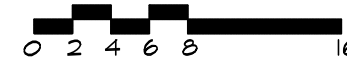

Roof Plan 'D'

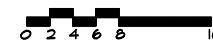

--- DENOTES WINDOW GRIDS & TRIM AT SIDE ELEVATIONS FACING STREETS.

PLAN 4
Elevation D
STONEBROOK

BRENTWOOD, CA

West Coast
 HOME BUILDERS

LEGACY
 DESIGN GROUP

DATE JULY 01, 2024

4.8



Elevation A - Tuscan



Elevation B - French Cottage



Elevation C - Craftsman



Elevation D - Bay Area Modern

MATERIAL LEGEND

- | | |
|---|---|
| <p>A VILLA CONCRETE TILE ROOFING
HIP & GABLE ROOFS
STUCCO BODY
STUCCO/FOAM TRIM
STUCCO/FOAM CORBELS
DECORATIVE WROUGHT IRON
DECORATIVE FOAM
ROLL-UP GARAGE DOORS
W/ OPT. WINDOW LITES</p> | <p>B FLAT CONCRETE TILE ROOFING
HIP & GABLE ROOFS
STUCCO BODY
STUCCO/FOAM TRIM
MOCK VENTS
DECORATIVE FOAM
SIMULATED STONE VENEER
MOCK WOOD SHUTTERS
ROLL-UP GARAGE DOORS
W/ OPT. WINDOW LITES</p> |
| <p>C FLAT CONCRETE TILE ROOFING
HIP & GABLE ROOFS
STUCCO BODY
STUCCO/FOAM TRIM
LAP SIDING
DECORATIVE FOAM
SIMULATED STONE VENEER
STUCCO/FOAM CORBELS
ROLL-UP GARAGE DOORS
W/ OPT. WINDOW LITES</p> | <p>D FLAT CONCRETE TILE ROOFING
GABLE ROOFS
STUCCO BODY
STUCCO/FOAM TRIM
BOARD & BATTEN
MOCK VENTS
DECORATIVE FOAM
WOOD KICKERS
SIMULATED STONE VENEER
ROLL-UP GARAGE DOORS
W/ OPT. WINDOW LITES</p> |

PLAN 5
Front Elevations
STONEBROOK

BRENTWOOD, CA

West Coast
HOME BUILDERS

LEGACY
DESIGN GROUP

DATE JULY 01, 2024

5.1

City of Brentwood
MINIMUM REQUIREMENTS

FRONT SETBACK - TO LIVING	10' MIN.
FRONT SETBACK - TO GARAGE	20' MIN.
SIDE YARD - SETBACK	5' MIN.
REAR YARD - SETBACK	15' MIN.
PORCH SETBACK	10' MIN.
LOT SIZE -	4,500 SQ. FT.
MAX COVERAGE - 2-STORY	40%

LOT COVERAGE 2-STORY: 40% max		
TYPICAL LOT SIZES	FOOTPRINT	APPROX. COVERAGE
45' x 100' = 4,500 SQ. FT.	1,592 SQ. FT.	35%

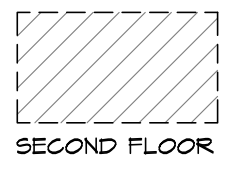
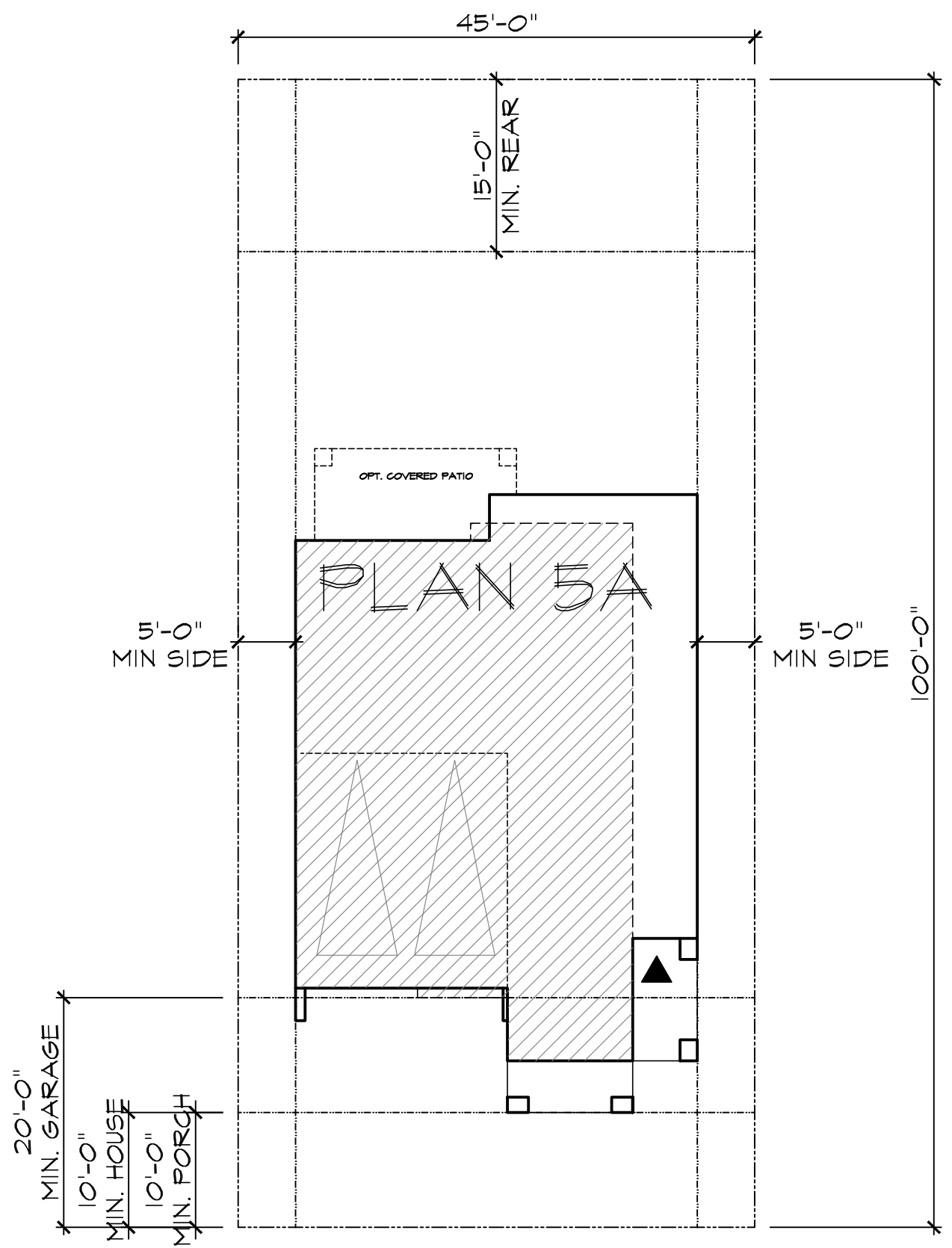

PLAN 5
Site Plan
STONEBROOK

BRENTWOOD, CA

West Coast
HOME BUILDERS

LEGACY
DESIGN GROUP

DATE JULY 01, 2024

5.2

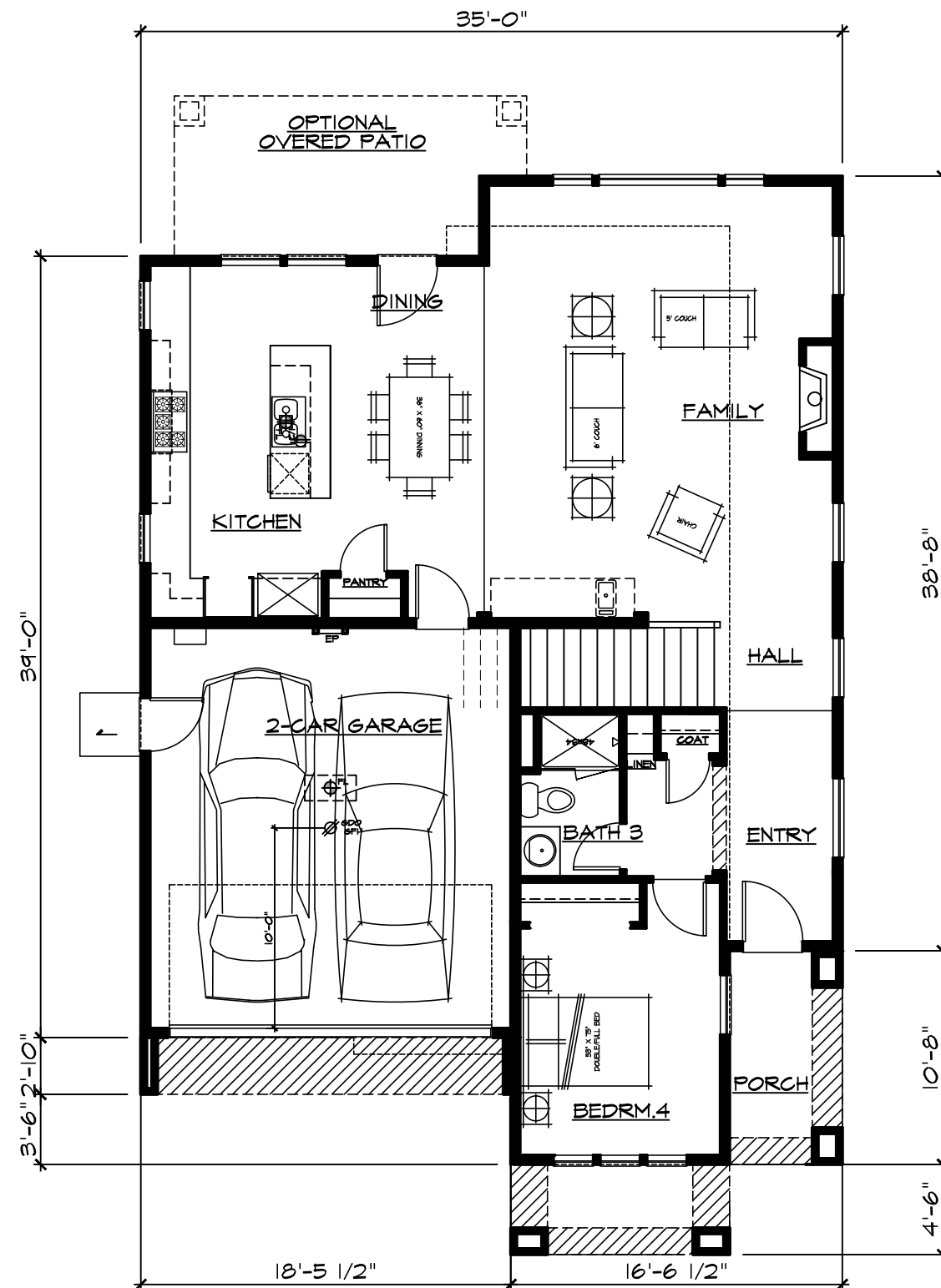

SQUARE FOOTAGE	
FIRST FLOOR	1105 SF
SECOND FLOOR	1135 SF
TOTAL LIVING AREA	2292 SF
<hr/>	
GARAGE	378 SF
PORCH	109 SF
OPTIONAL REAR PATIO	131 SF
FOOTPRINT	1592 SF

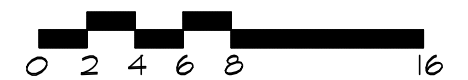

PLAN 5

First Floor

STONEBROOK

BRENTWOOD, CA

West Coast
HOME BUILDERS

LEGACY
DESIGN GROUP

DATE JULY 01, 2024

5.3

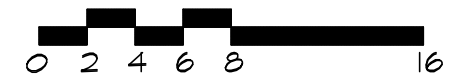
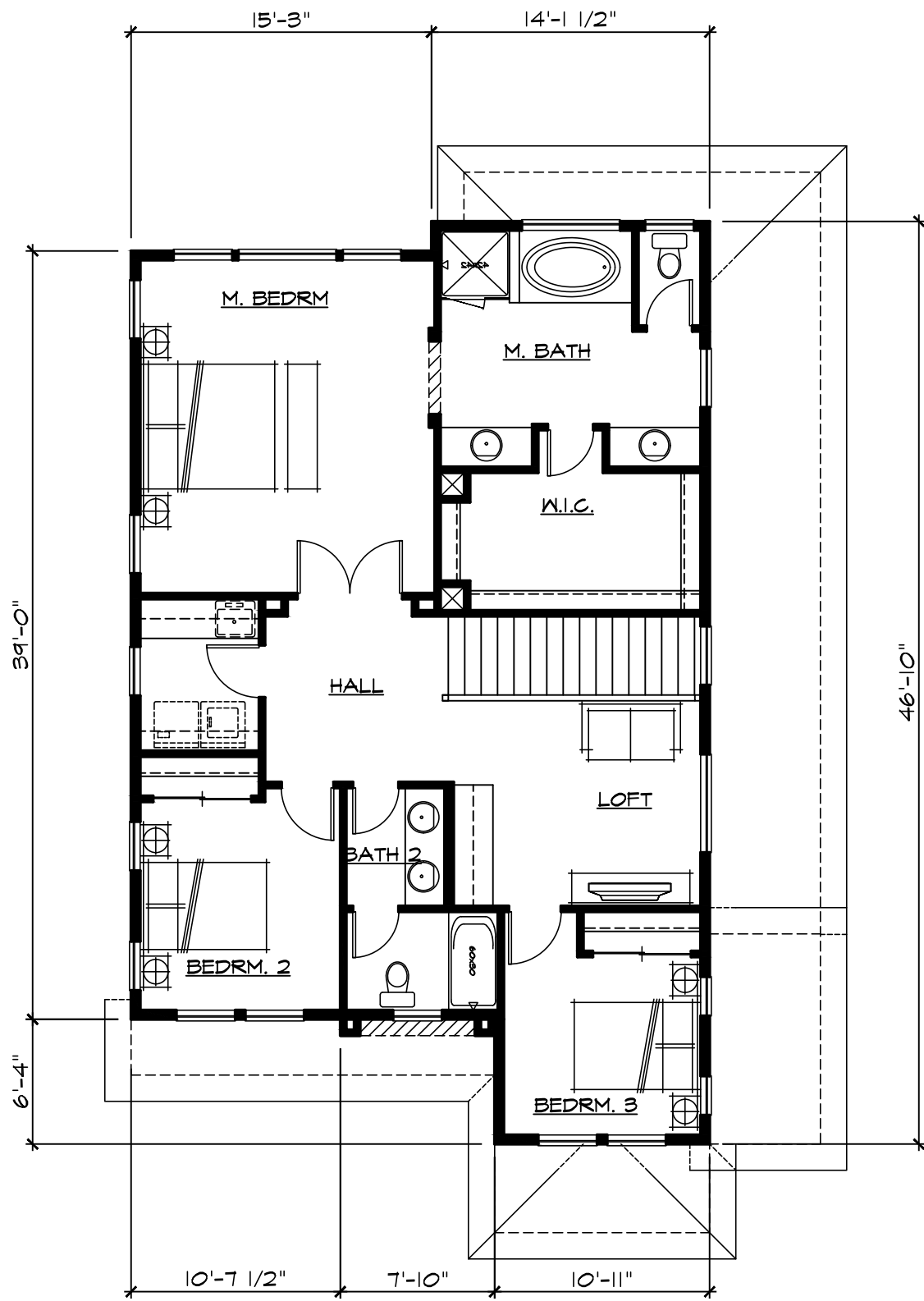

PLAN 5
Second Floor
STONEBROOK

BRENTWOOD, CA

West Coast
 HOME BUILDERS

LEGACY
DESIGN **G**ROUP

DATE JULY 01, 2024

5.4



Right



Front - Tuscan



Left

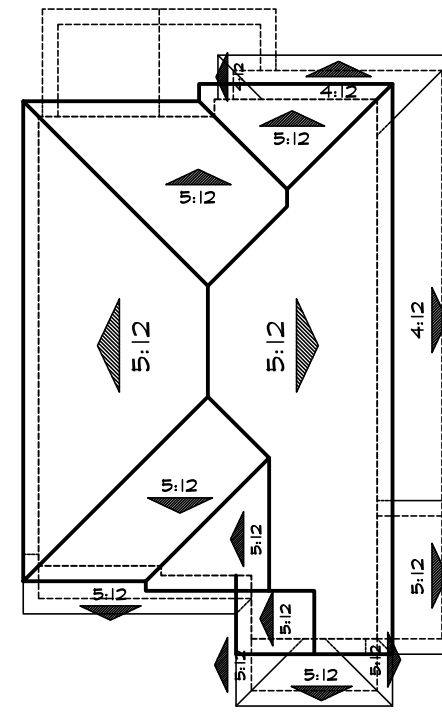

Roof Plan 'A'



--- DENOTES WINDOW GRIDS & TRIM AT SIDE ELEVATIONS FACING STREETS.



Rear

PLAN 5
Elevation A
STONEBROOK

BRENTWOOD, CA

West Coast
HOME BUILDERS

LEGACY
DESIGN GROUP

DATE JULY 01, 2024

5.5

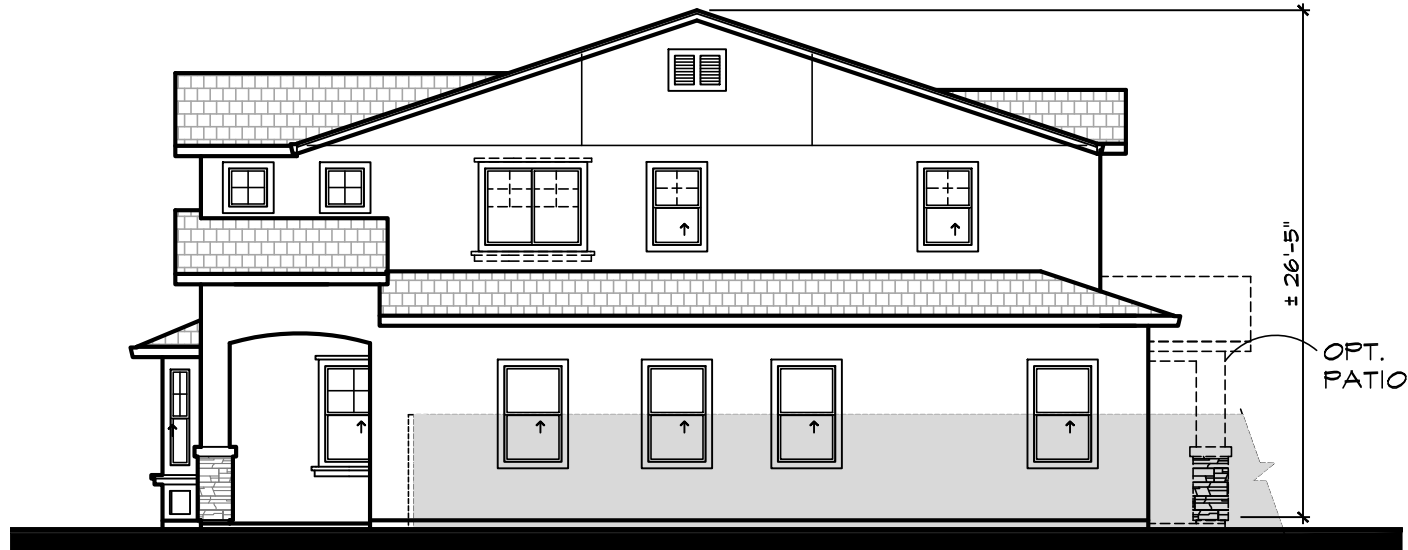

Right



Front - French Cottage



Left

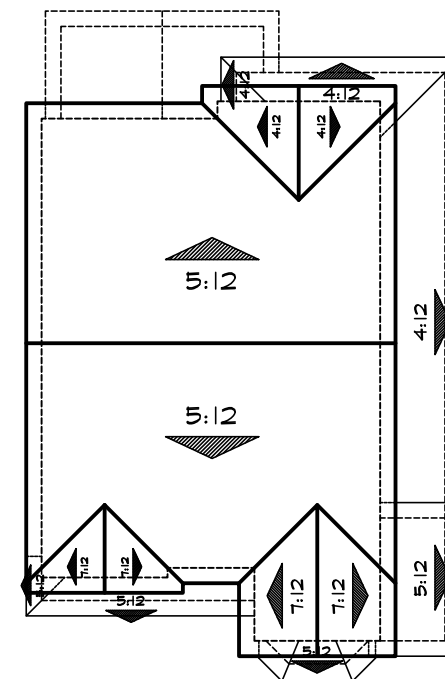

Roof Plan 'B'

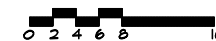

--- DENOTES WINDOW GRIDS & TRIM AT SIDE ELEVATIONS FACING STREETS.

PLAN 5
Elevation B
STONEBROOK

BRENTWOOD, CA

West Coast
 HOME BUILDERS

LEGACY
 DESIGN GROUP

DATE JULY 01, 2024

5.6



Rear

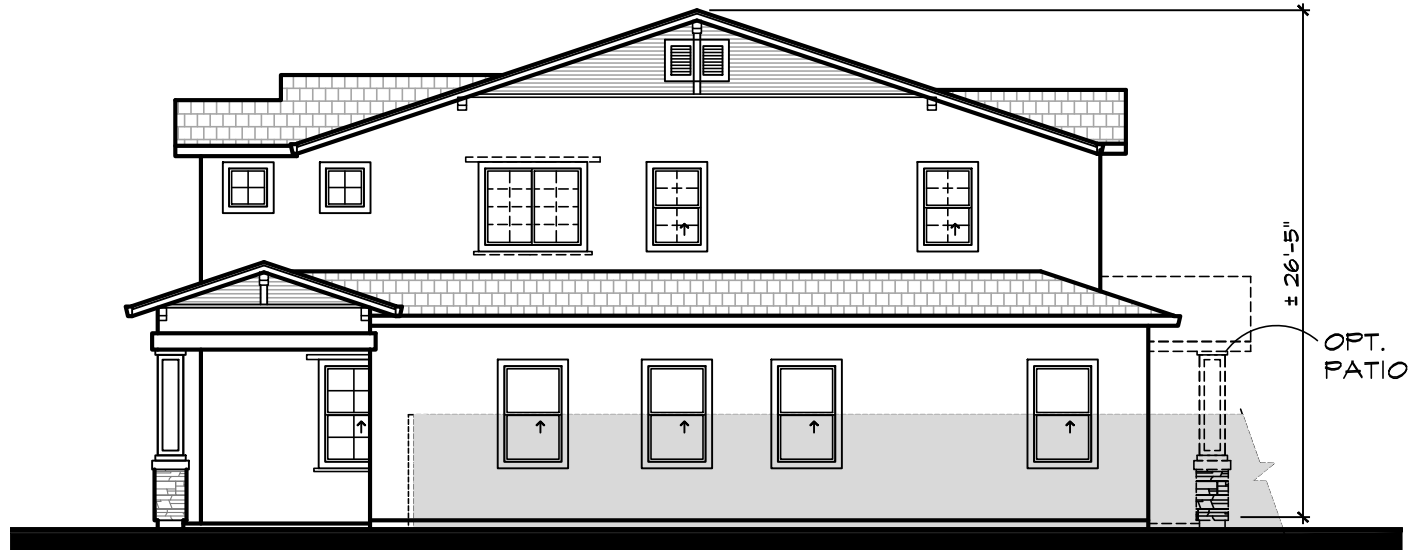

Right



Front - Craftsman

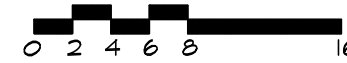

Left

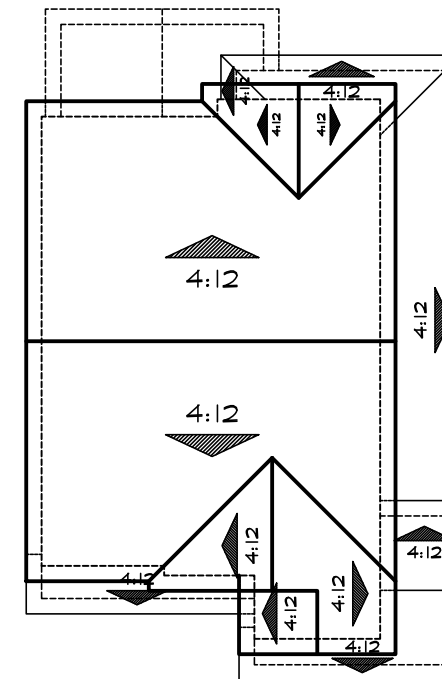

--- DENOTES WINDOW GRIDS & TRIM AT SIDE ELEVATIONS FACING STREETS.



Rear

Roof Plan 'C'



PLAN 5
Elevation C
STONEBROOK

BRENTWOOD, CA

West Coast
 HOME BUILDERS

LEGACY
 DESIGN GROUP

DATE JULY 01, 2024

5.7

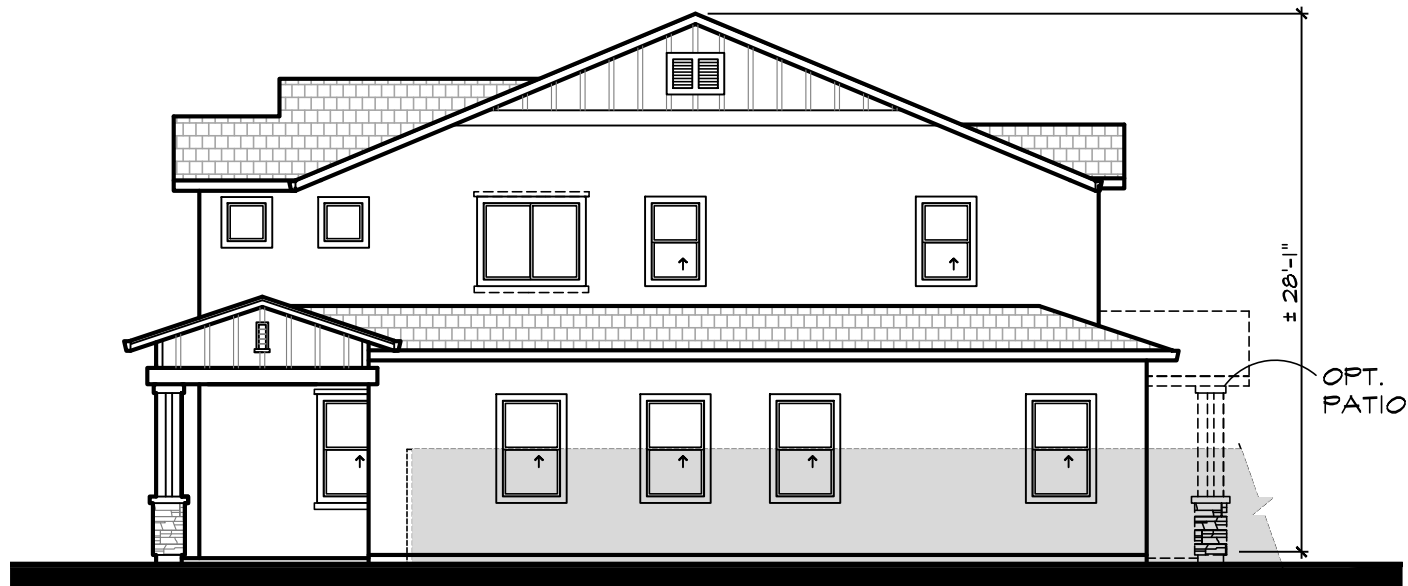

Right



Front - Bay Area Modern

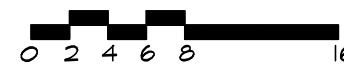

Left

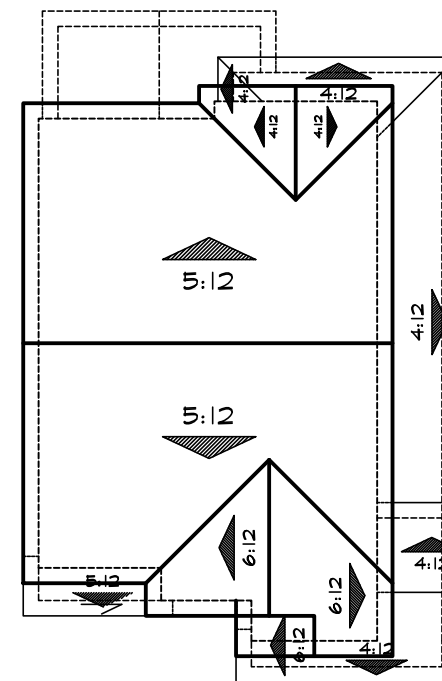

Roof Plan 'D'



DENOTES WINDOW GRIDS & TRIM AT SIDE ELEVATIONS FACING STREETS.

PLAN 5
Elevation D
STONEBROOK

BRENTWOOD, CA

West Coast
HOME BUILDERS

LEGACY
DESIGN GROUP

DATE JULY 01, 2024

5.8



Rear



Elevation A - Tuscan



Elevation B - French Cottage

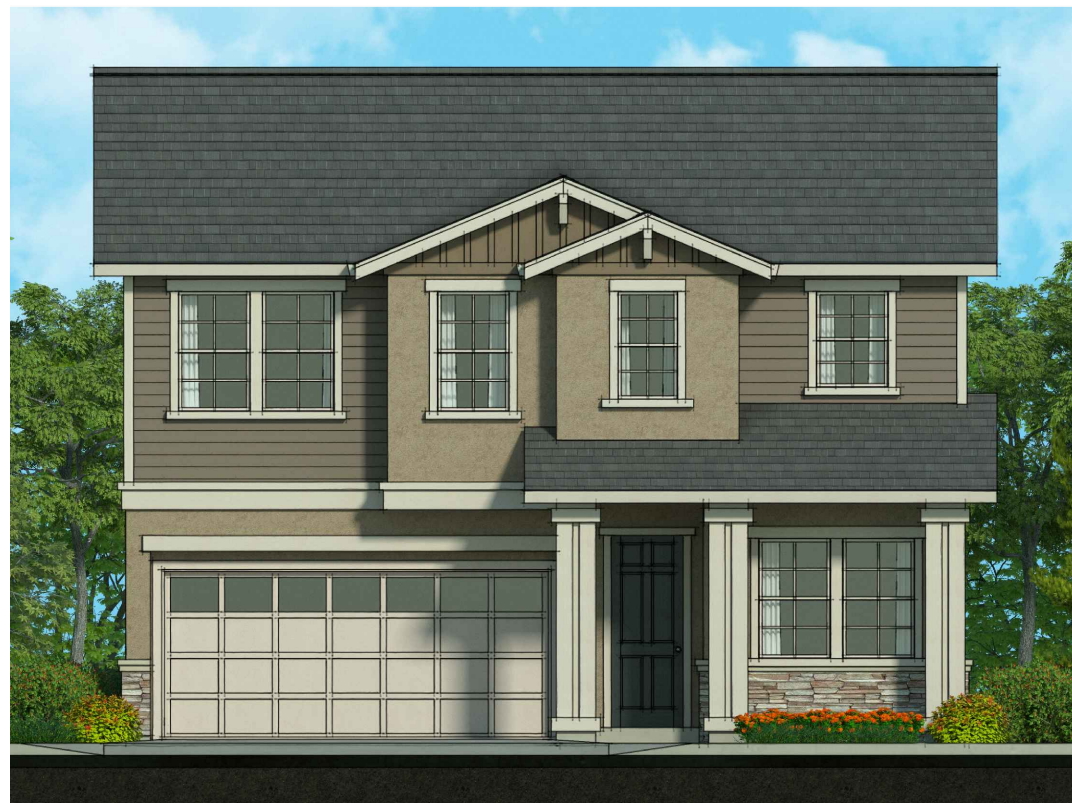

Elevation C - Craftsman



Elevation D - Bay Area Modern

MATERIAL LEGEND

- | | |
|--|---|
| <p>A VILLA CONCRETE TILE ROOFING
HIP & GABLE ROOFS
STUCCO BODY
STUCCO/FOAM TRIM
SIMULATED STONE BRICK
DECORATIVE FOAM
ROLL-UP GARAGE DOORS
W/ OPT. WINDOW LITES</p> | <p>B FLAT CONCRETE TILE ROOFING
GABLE ROOFS
STUCCO BODY
STUCCO/FOAM TRIM
MOCK VENTS
DECORATIVE FOAM
SIMULATED STONE VENEER
MOCK WOOD SHUTTERS
ROLL-UP GARAGE DOORS
W/ OPT. WINDOW LITES</p> |
| <p>C FLAT CONCRETE TILE ROOFING
GABLE ROOFS
STUCCO BODY
STUCCO/FOAM TRIM
LAP SIDING
SIMULATED STONE VENEER
STUCCO/FOAM CORBELS
BOARD & BATTEN
DECORATIVE FOAM
ROLL-UP GARAGE DOORS
W/ OPT. WINDOW LITES</p> | <p>D FLAT CONCRETE TILE ROOFING
GABLE ROOFS
STUCCO BODY
STUCCO/FOAM TRIM
BOARD & BATTEN
MOCK VENTS
SIMULATED STONE VENEER
DECORATIVE FOAM
WOOD KICKERS
ROLL-UP GARAGE DOORS
W/ OPT. WINDOW LITES</p> |

PLAN 6
Front Elevations
STONEBROOK

BRENTWOOD, CA

West Coast
HOME BUILDERS

LEGACY
DESIGN GROUP

DATE JULY 01, 2024

6.1

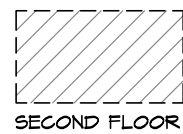
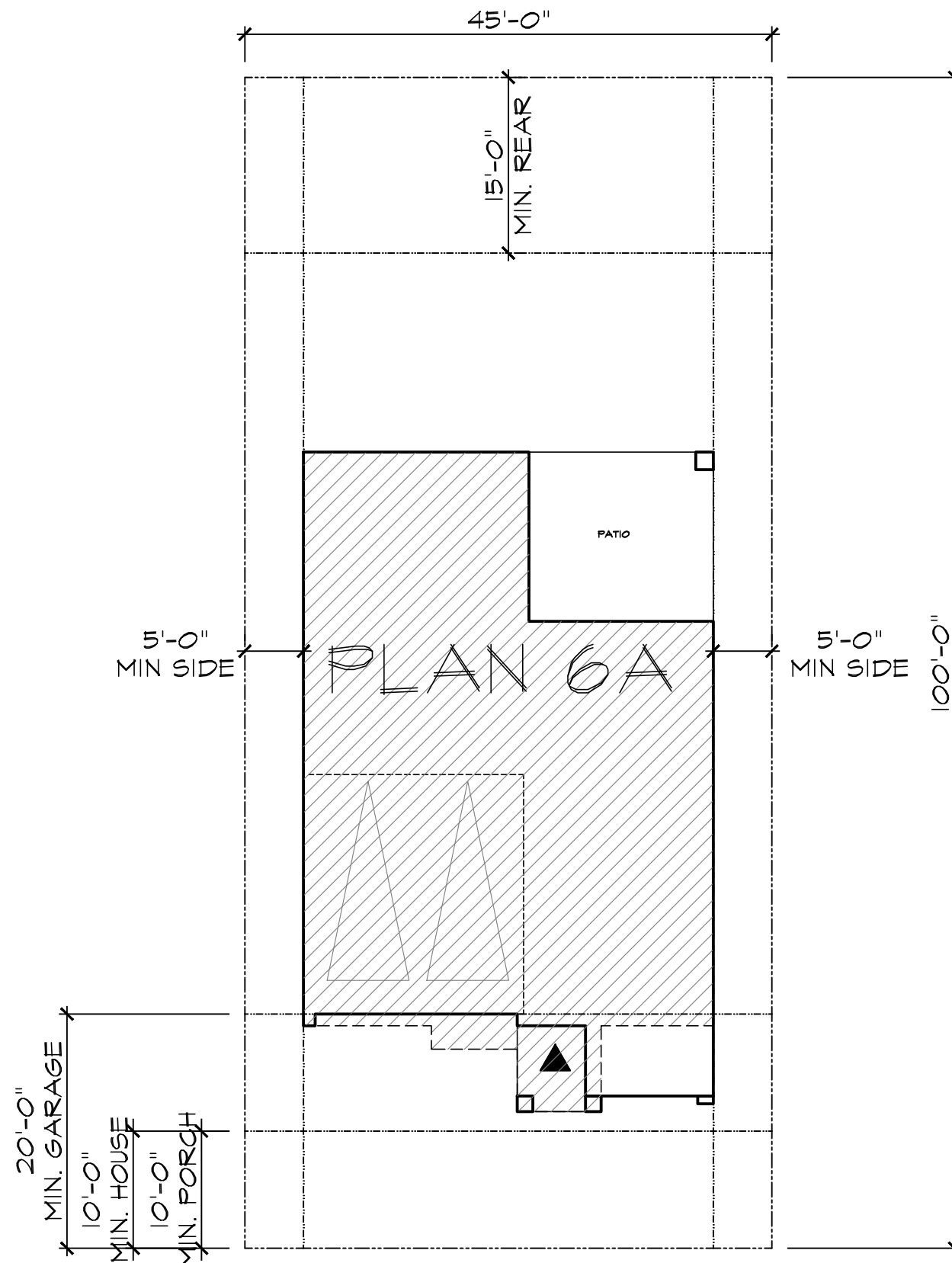

City of Brentwood
MINIMUM REQUIREMENTS

FRONT SETBACK - TO LIVING	10' MIN.
FRONT SETBACK - TO GARAGE	20' MIN.
SIDE YARD - SETBACK	5' MIN.
REAR YARD - SETBACK	15' MIN.
PORCH SETBACK	10' MIN.
LOT SIZE	4,500 SQ. FT.
MAX COVERAGE - 2-STORY	40%

LOT COVERAGE 2-STORY: 40% max		
TYPICAL LOT SIZES	FOOTPRINT	APPROX. COVERAGE
45' x 100' = 4,500 SQ. FT.	1,806 SQ. FT.	40%

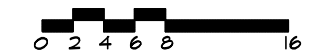

PLAN 6
Site Plan
STONEBROOK

BRENTWOOD, CA

West Coast
HOME BUILDERS

LEGACY
DESIGN GROUP

DATE JULY 01, 2024

6.2

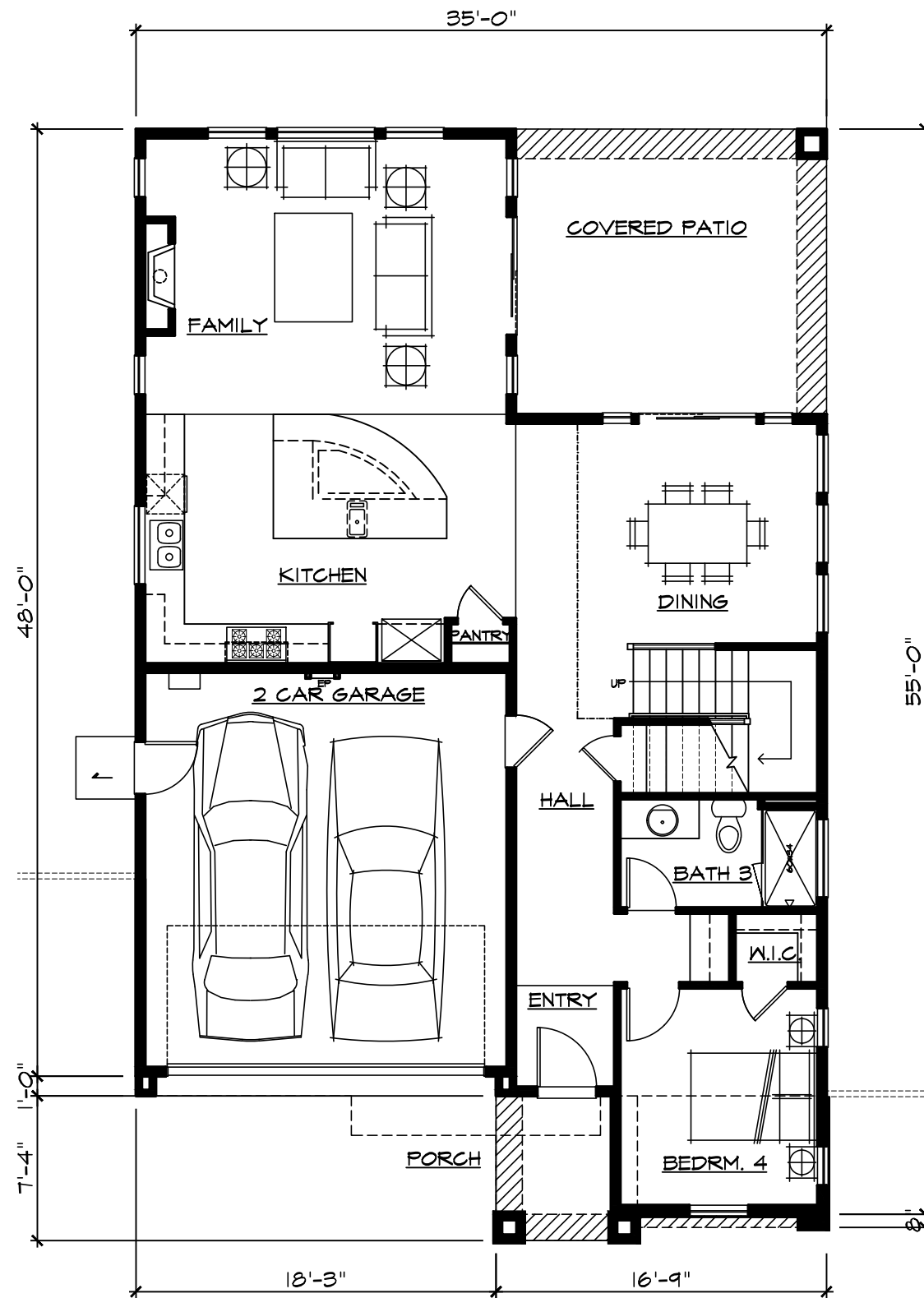

SQUARE FOOTAGE	
FIRST FLOOR	1149 SF
SECOND FLOOR	1290 SF
TOTAL LIVING AREA	2439 SF
<hr/>	
GARAGE	384 SF
COVERED PATIO	228 SF
PORCH	45 SF
FOOTPRINT W/ COVER PATIO	1806 SF



PLAN 6

First Floor

STONEBROOK

BRENTWOOD, CA

West Coast
HOME BUILDERS

LEGACY
DESIGN GROUP

DATE JULY 01, 2024

6.3

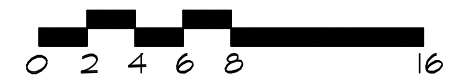
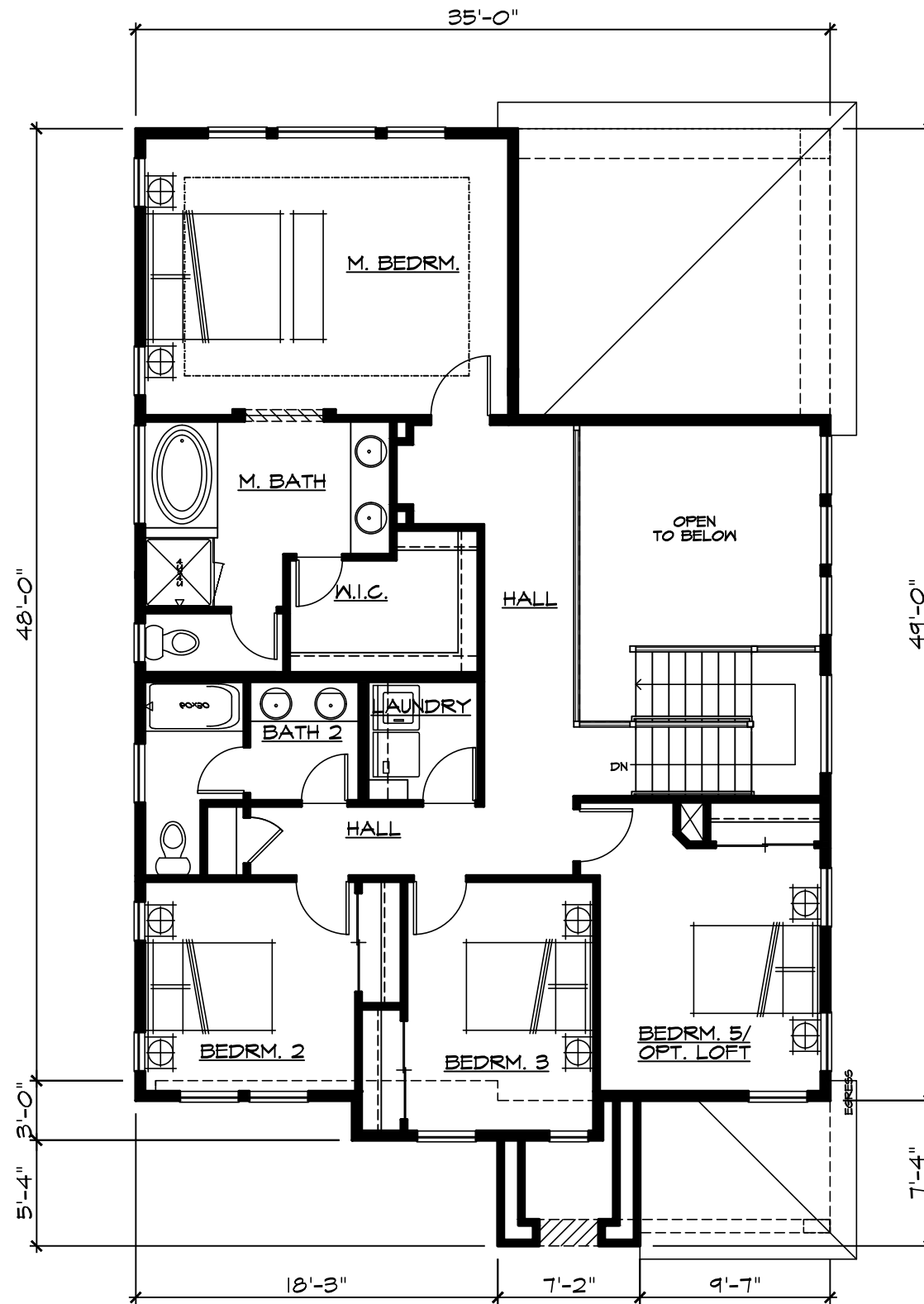

PLAN 6

Second Floor

STONEBROOK

BRENTWOOD, CA

West Coast
HOME BUILDERS

LEGACY
DESIGN GROUP

DATE JULY 01, 2024

6.4



Right



Front - Tuscan



Left

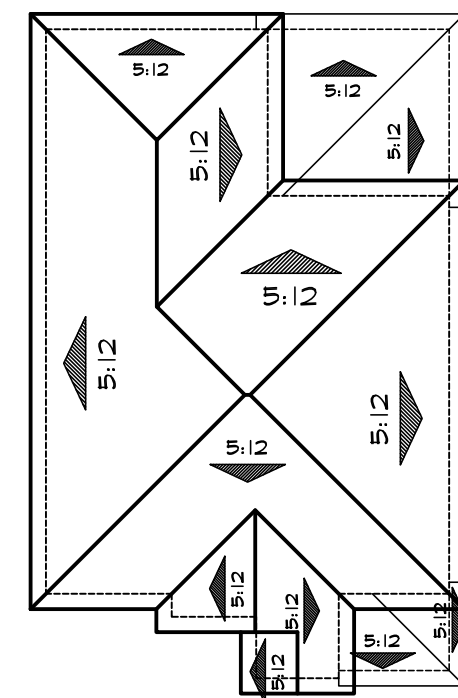

--- DENOTES WINDOW GRIDS & TRIM AT SIDE ELEVATIONS FACING STREETS.



Rear

Roof Plan 'A'



PLAN 6
Elevation A
STONEBROOK

BRENTWOOD, CA

West Coast
 HOME BUILDERS

LEGACY
 DESIGN GROUP

DATE JULY 01, 2024

6.5



Right



Front - French Cottage

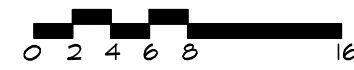

Left



Rear

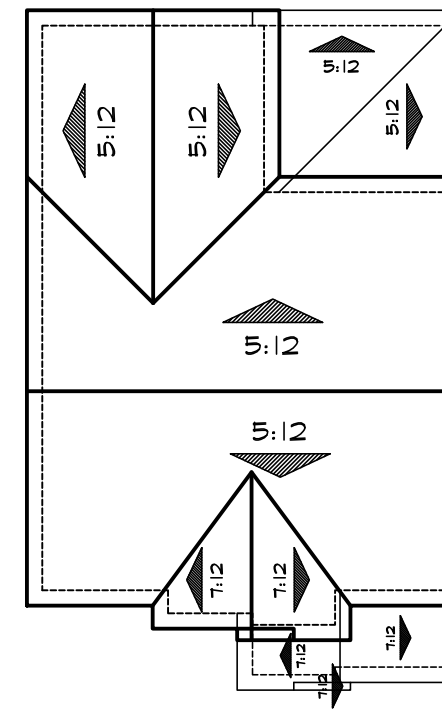

Roof Plan 'B'

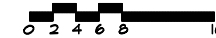

--- DENOTES WINDOW GRIDS, TRIM, & SHUTTERS AT SIDE ELEVATIONS FACING STREETS.

PLAN 6
Elevation B
STONEBROOK

BRENTWOOD, CA

West Coast
HOME BUILDERS

LEGACY
DESIGN GROUP

DATE JULY 01, 2024

6.6



Right

± 27'-0"



Front - Craftsman

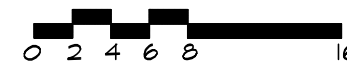

Left



Rear

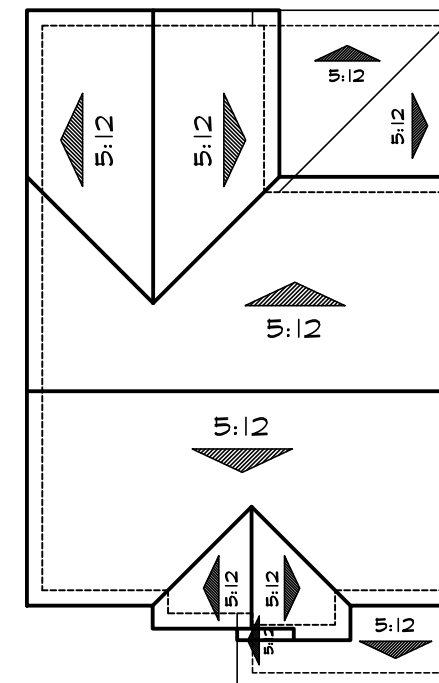

Roof Plan 'C'



--- DENOTES WINDOW GRIDS & TRIM AT SIDE ELEVATIONS FACING STREETS.

PLAN 6
Elevation C
STONEBROOK

BRENTWOOD, CA

West Coast
HOME BUILDERS

LEGACY
DESIGN GROUP

DATE JULY 01, 2024

6.7



Right

± 27'-0"



Left

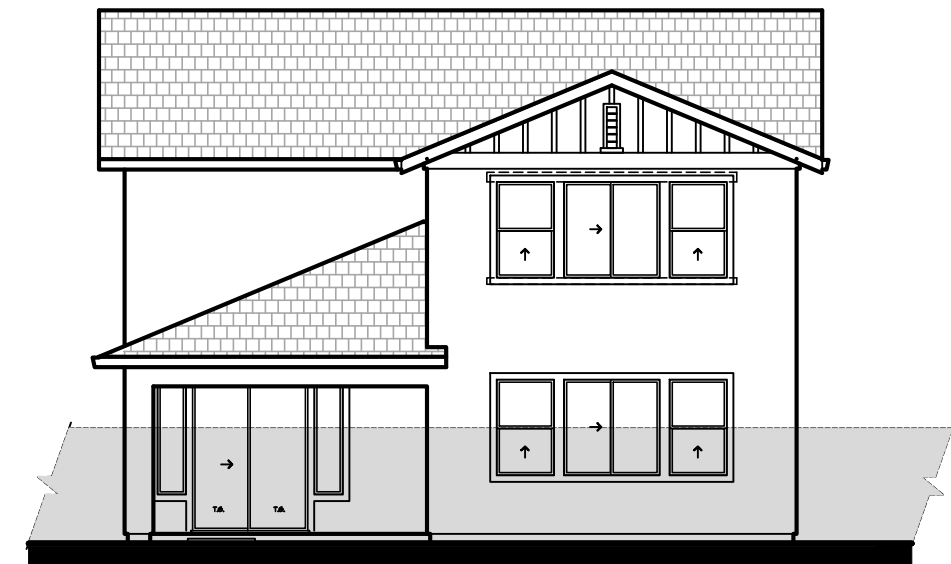

Rear



Front - Bay Area Modern

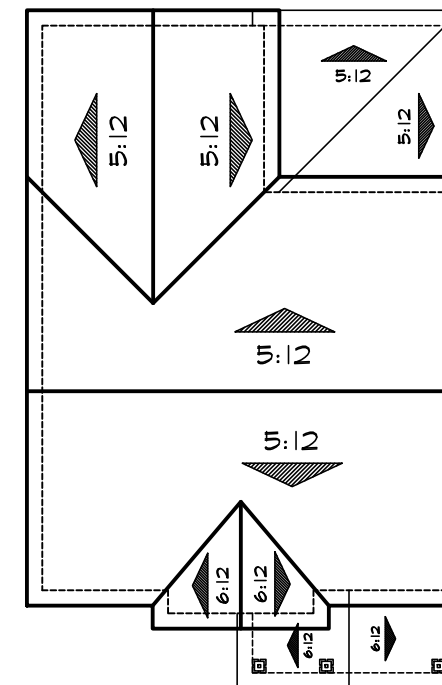

Roof Plan 'D'



DENOTES WINDOW GRIDS & TRIM AT SIDE ELEVATIONS FACING STREETS.

PLAN 6
Elevation D
STONEBROOK

BRENTWOOD, CA

West Coast
HOME BUILDERS

LEGACY
DESIGN GROUP

DATE JULY 01, 2024

6.8



Elevation A - Tuscan



Elevation B - French Cottage



Elevation C - Craftsman



Elevation D - Bay Area Modern

MATERIAL LEGEND

- | | |
|---|---|
| <p>A VILLA CONCRETE TILE ROOFING
HIP & GABLE ROOFS
STUCCO BODY
STUCCO/FOAM TRIM
SIMULATED STONE VENEER
STUCCO/FOAM CORBELS
DECORATIVE FOAM
ROLL-UP GARAGE DOORS
W/ OPT. WINDOW LITES</p> | <p>B FLAT CONCRETE TILE ROOFING
HIP & GABLE ROOFS
STUCCO BODY
STUCCO/FOAM TRIM
MOCK VENTS
DECORATIVE FOAM
SIMULATED STONE VENEER
ROLL-UP GARAGE DOORS
W/ OPT. WINDOW LITES</p> |
| <p>C FLAT CONCRETE TILE ROOFING
GABLE ROOFS
STUCCO BODY
STUCCO/FOAM TRIM
LAP SIDING
WOOD TRIM
DECORATIVE FOAM
SIMULATED STONE VENEER
STUCCO/FOAM CORBELS
ROLL-UP GARAGE DOORS
W/ OPT. WINDOW LITES</p> | <p>D FLAT CONCRETE TILE ROOFING
GABLE ROOFS
STUCCO BODY
STUCCO/FOAM TRIM
BOARD & BATTEN
MOCK VENTS
SIMULATED STONE VENEER
DECORATIVE FOAM
WOOD KICKERS
ROLL-UP GARAGE DOORS
W/ OPT. WINDOW LITES</p> |

PLAN 7
Front Elevations
STONEBROOK

BRENTWOOD, CA

West Coast
HOME BUILDERS

LEGACY
DESIGN GROUP

DATE JULY 01, 2024

7.1

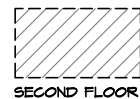
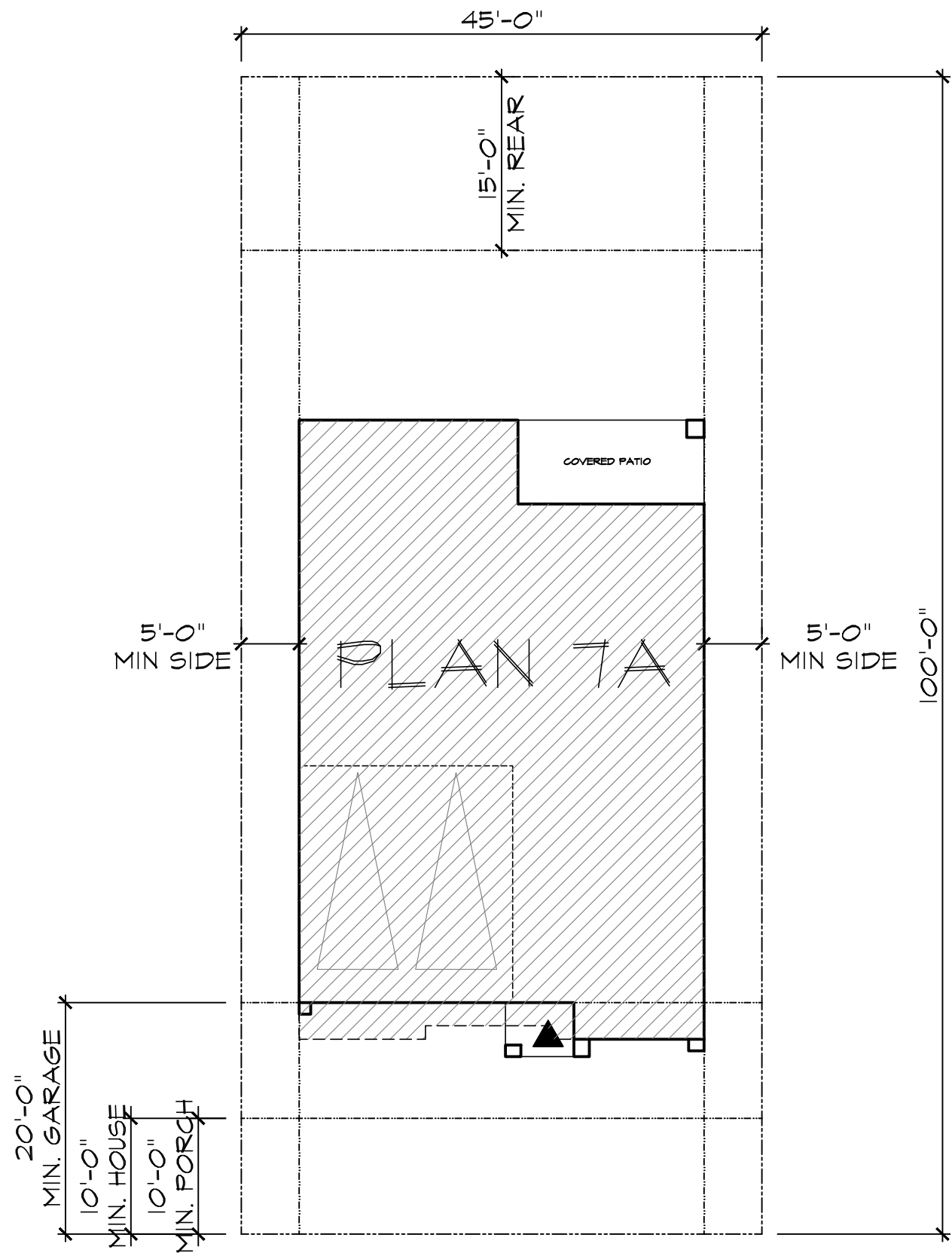

SECOND FLOOR

City of Brentwood
MINIMUM REQUIREMENTS

FRONT SETBACK - TO LIVING	10' MIN.
FRONT SETBACK - TO GARAGE	20' MIN.
SIDE YARD - SETBACK	5' MIN.
REAR YARD - SETBACK	15' MIN.
PORCH SETBACK	10' MIN.
LOT SIZE	4,500 SQ. FT.
MAX COVERAGE - 2-STORY	40%

LOT COVERAGE		
2-STORY: 40% max		
TYPICAL LOT SIZES	FOOTPRINT	APPROX. COVERAGE
45' x 100' = 4,500 SQ. FT.	1,826 SQ. FT.	40%

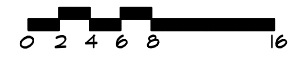

PLAN 7
SitePlan
STONEBROOK

BRENTWOOD, CA

West Coast
HOME BUILDERS

LEGACY
DESIGN GROUP

DATE JULY 01, 2024

7.2

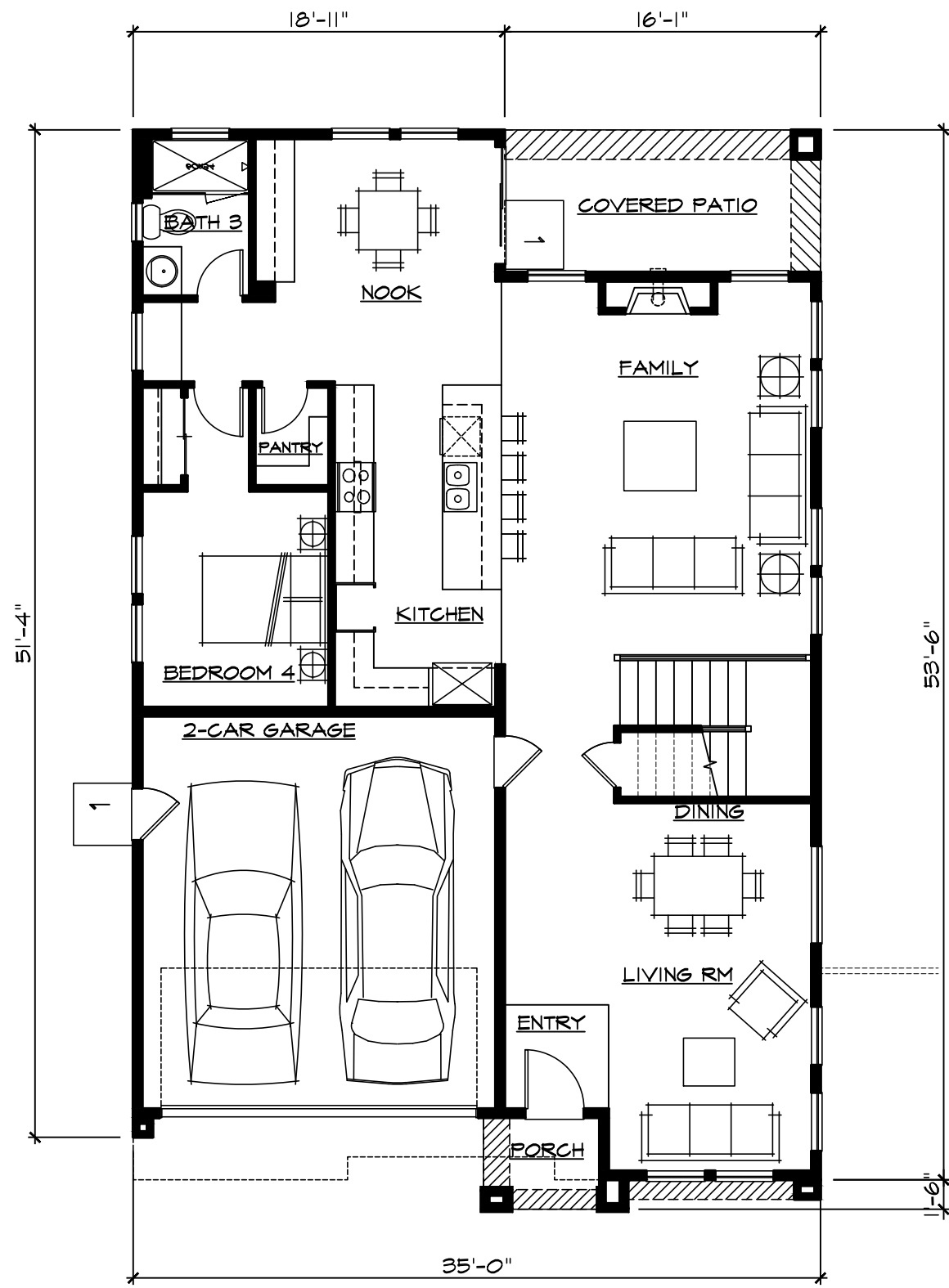

SQUARE FOOTAGE	
FIRST FLOOR	1303 SF
SECOND FLOOR	1341 SF
TOTAL LIVING AREA	2644 SF
GARAGE	378 SF
PORCH	28 SF
FOOTPRINT	1826 SF

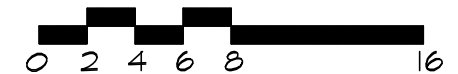

PLAN 7

First Floor

STONEBROOK

BRENTWOOD, CA

West Coast
HOME BUILDERS

LEGACY
DESIGN GROUP

DATE JULY 01, 2024

7.3

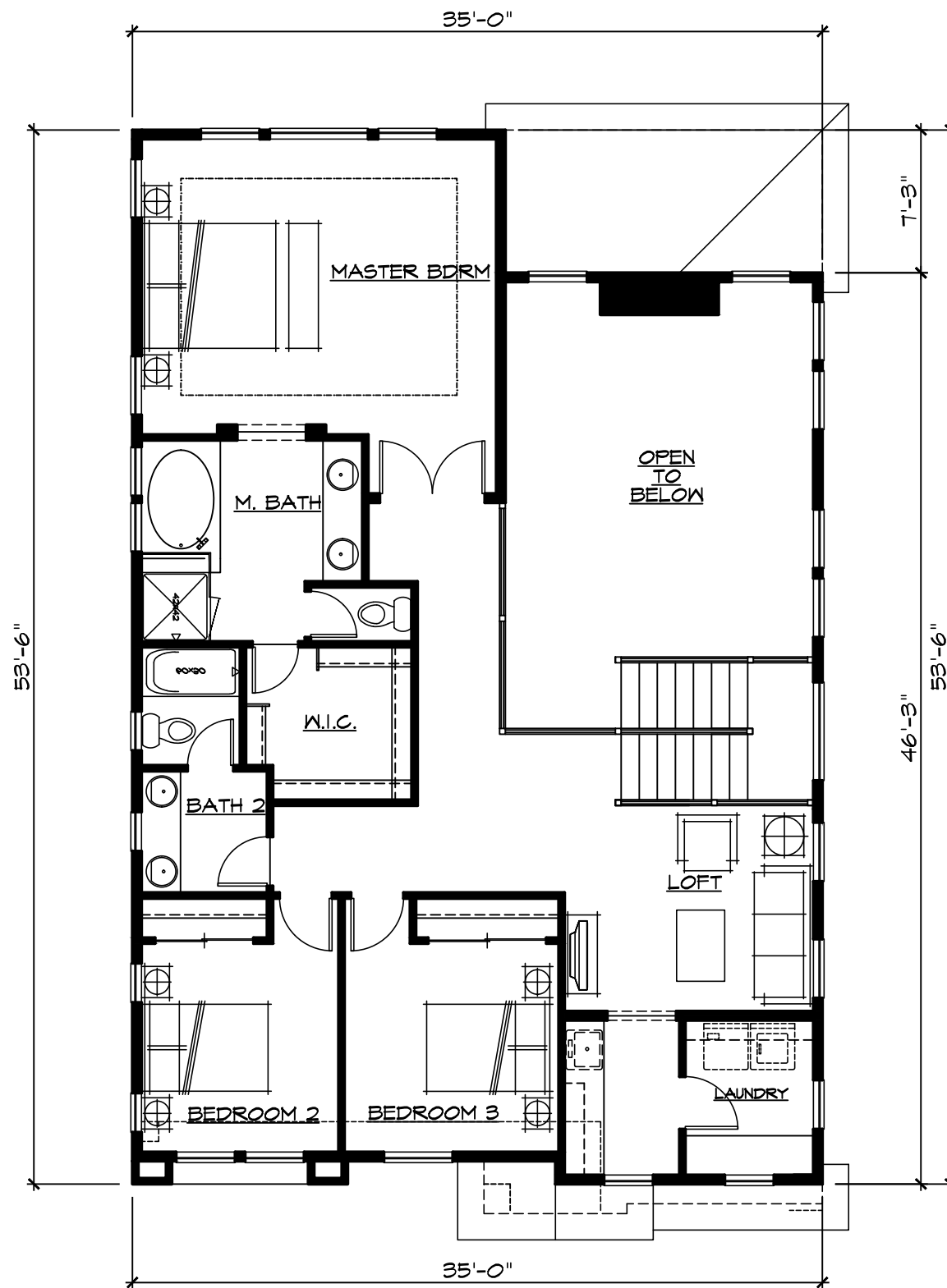

PLAN 7
Second Floor
STONEBROOK

BRENTWOOD, CA

West Coast
 HOME BUILDERS

LEGACY
DESIGN GROUP

DATE JULY 01, 2024

7.4



Right



Left



Rear



Front - Tuscan

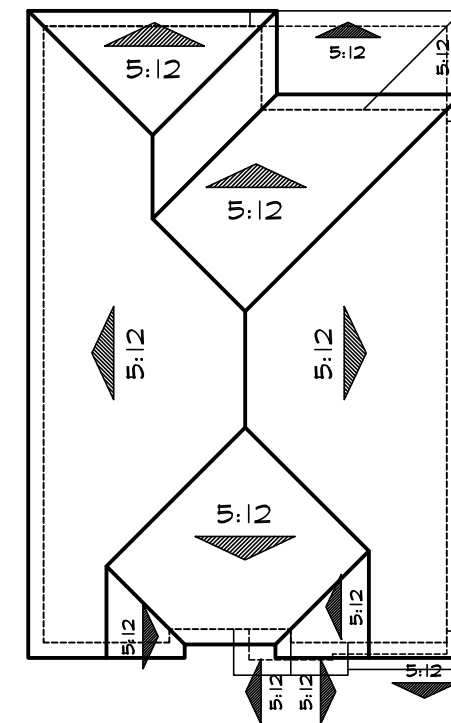
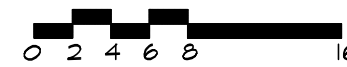

Roof Plan 'A'



--- DENOTES WINDOW GRIDS & TRIM AT SIDE ELEVATIONS FACING STREETS.

PLAN 7
Elevation A
STONEBROOK

BRENTWOOD, CA

West Coast
HOME BUILDERS

LEGACY
DESIGN GROUP

DATE JULY 01, 2024

7.5

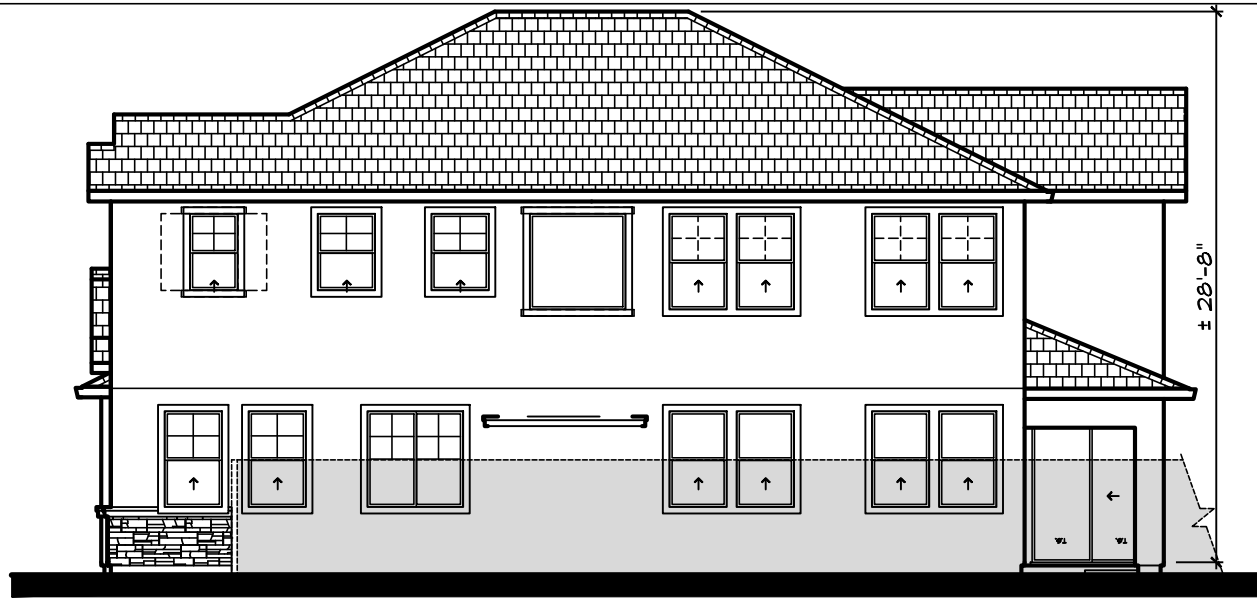

Right

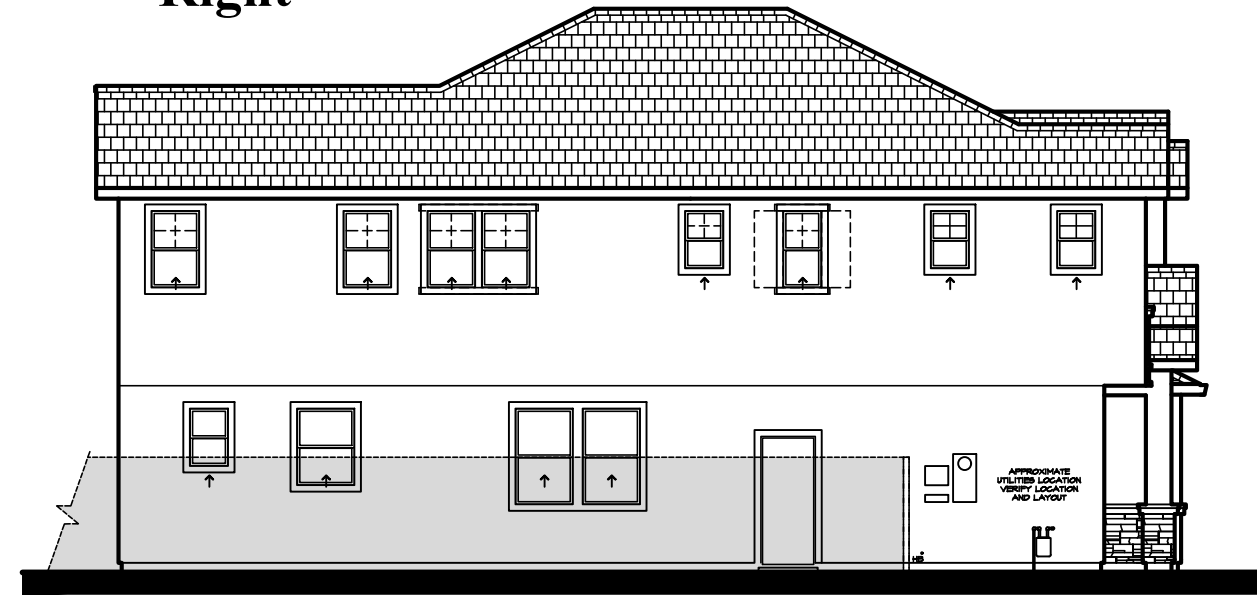

Left



Rear



Front - French Cottage

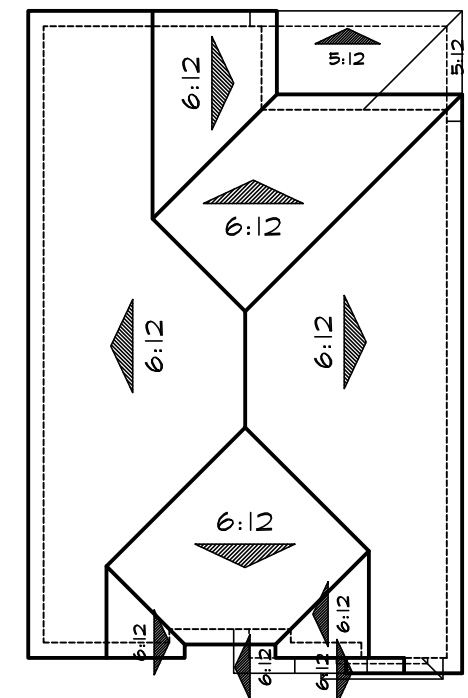
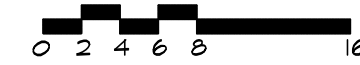

Roof Plan 'B'



--- DENOTES WINDOW GRIDS, TRIM, & SHUTTERS AT SIDE ELEVATIONS FACING STREETS.

PLAN 7
Elevation B
STONEBROOK

BRENTWOOD, CA

West Coast
HOME BUILDERS

LEGACY
DESIGN GROUP

DATE JULY 01, 2024

7.6

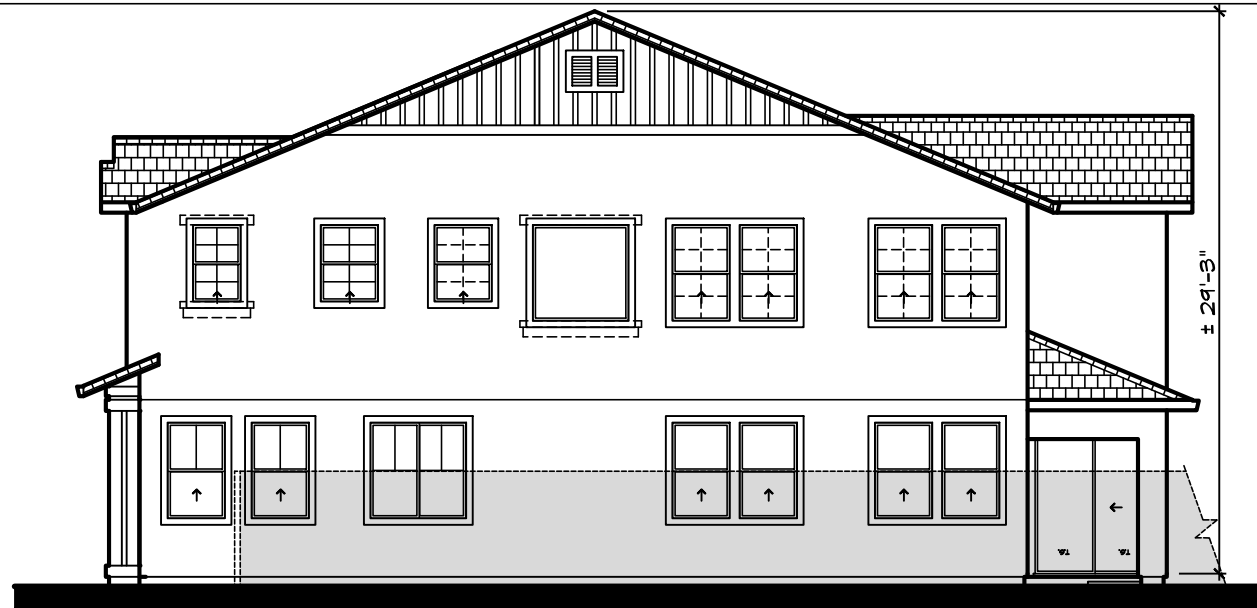

Right

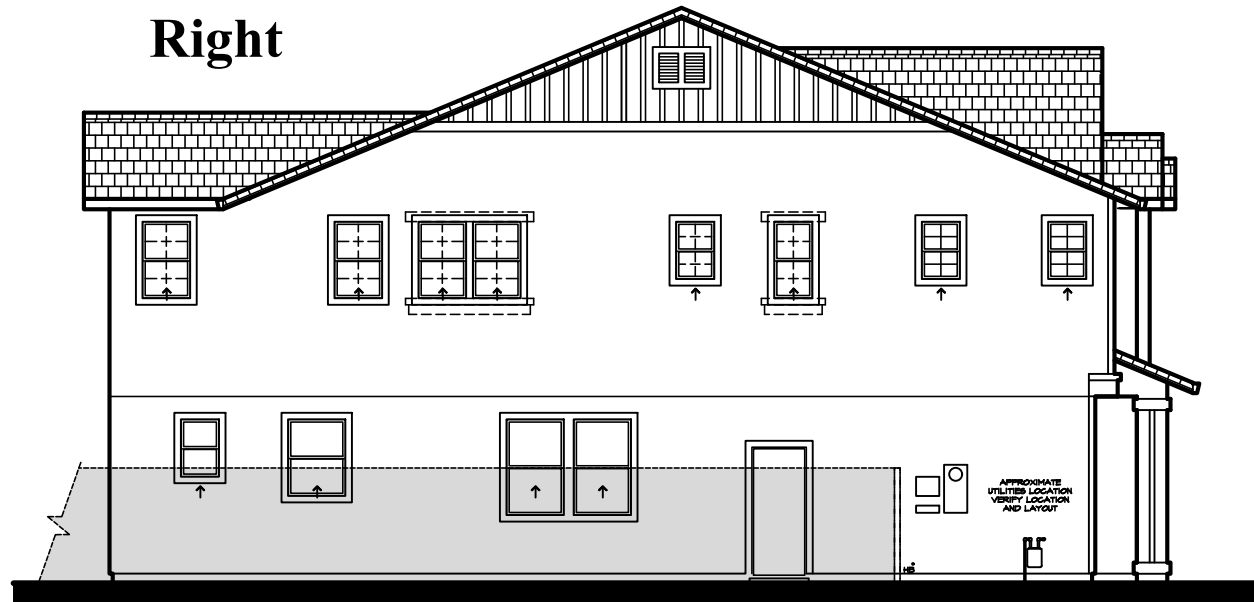

Left



Rear



Front - Craftsman

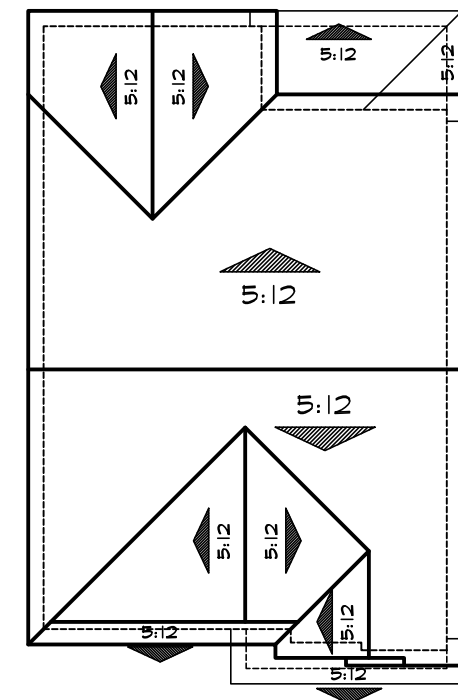
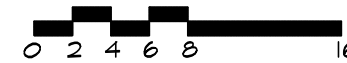

Roof Plan 'C'



--- DENOTES WINDOW GRIDS & TRIM AT SIDE ELEVATIONS FACING STREETS.

PLAN 7
Elevation C
STONEBROOK

BRENTWOOD, CA

West Coast
HOME BUILDERS

LEGACY
DESIGN GROUP

DATE JULY 01, 2024

7.7

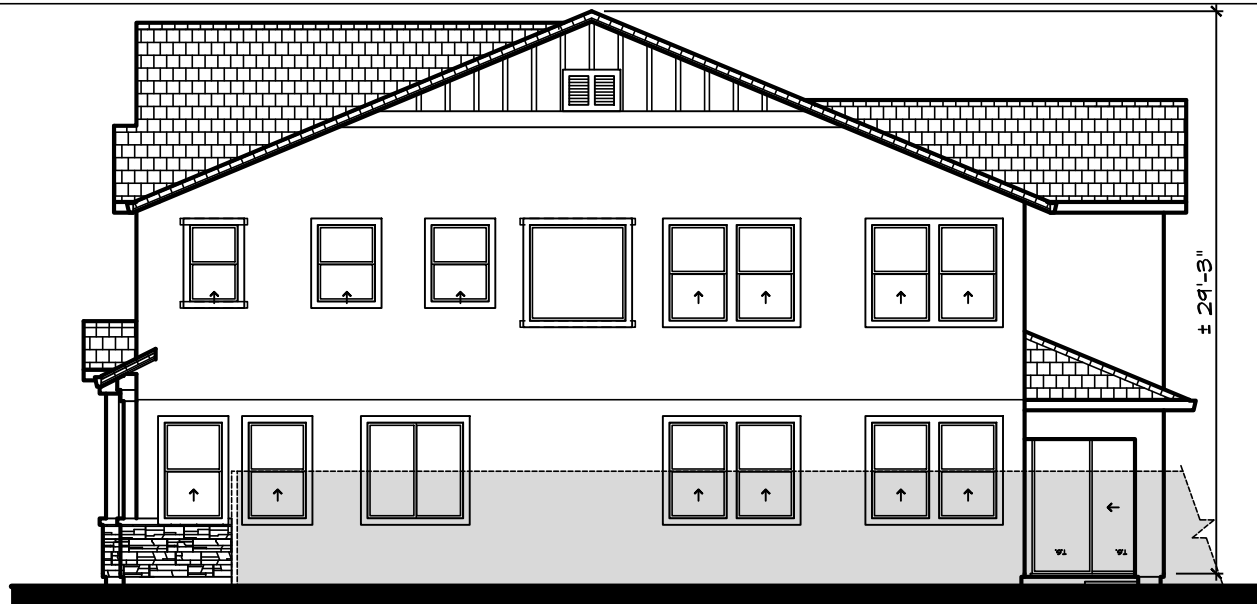

Right



Left



Rear



Front - Bay Area Modern

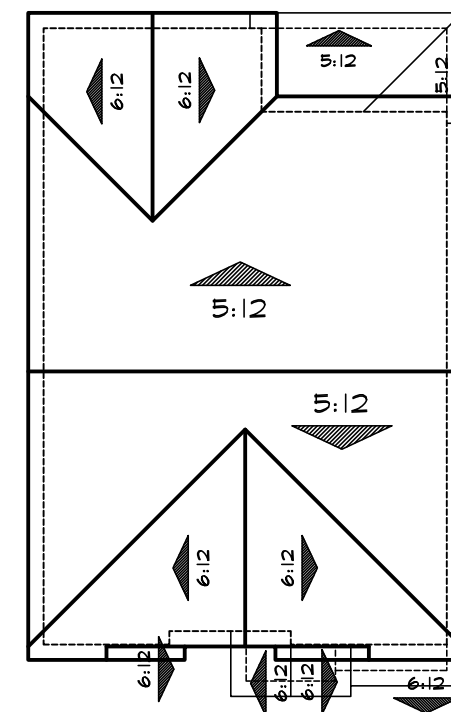
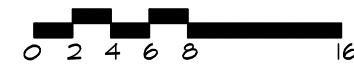

Roof Plan 'D'



DENOTES WINDOW GRIDS & TRIM AT SIDE ELEVATIONS FACING STREETS.

PLAN 7
Elevation D
STONEBROOK

BRENTWOOD, CA

West Coast
 HOME BUILDERS

LEGACY
 DESIGN GROUP

DATE JULY 01, 2024

7.8



Elevation A - Tuscan



Elevation B - French Cottage



Elevation C - Craftsman



Elevation D - Bay Area Modern

MATERIAL LEGEND

- | | |
|--|---|
| <p>A VILLA CONCRETE TILE ROOFING
HIP & GABLE ROOFS
STUCCO BODY
STUCCO/FOAM TRIM
STUCCO/FOAM CORBELS
DECORATIVE FOAM
DECORATIVE WROUGHT IRON
ROLL-UP GARAGE DOORS
W/ OPT. WINDOW LITES</p> | <p>B FLAT CONCRETE TILE ROOFING
HIP & GABLE ROOFS
STUCCO BODY
STUCCO/FOAM TRIM
MOCK VENTS
DECORATIVE FOAM
SIMULATED STONE VENEER
ROLL-UP GARAGE DOORS
W/ OPT. WINDOW LITES</p> |
| <p>C FLAT CONCRETE TILE ROOFING
GABLE ROOFS
STUCCO BODY
STUCCO/FOAM TRIM
LAP SIDING
DECORATIVE FOAM
SIMULATED STONE VENEER
STUCCO/FOAM CORBELS
WOOD RAILING
WOOD SHAKES
ROLL-UP GARAGE DOORS
W/ OPT. WINDOW LITES</p> | <p>D FLAT CONCRETE TILE ROOFING
GABLE ROOFS
STUCCO BODY
STUCCO/FOAM TRIM
BOARD & BATTEN
MOCK VENTS
DECORATIVE FOAM
WOOD KICKERS
SIMULATED STONE VENEER
ROLL-UP GARAGE DOORS
W/ OPT. WINDOW LITES</p> |

PLAN 8
Front Elevations
STONEBROOK

BRENTWOOD, CA

West Coast
HOME BUILDERS

LEGACY
DESIGN GROUP

DATE JULY 01, 2024

8.1

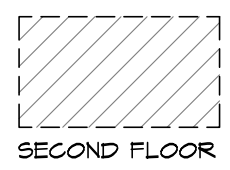
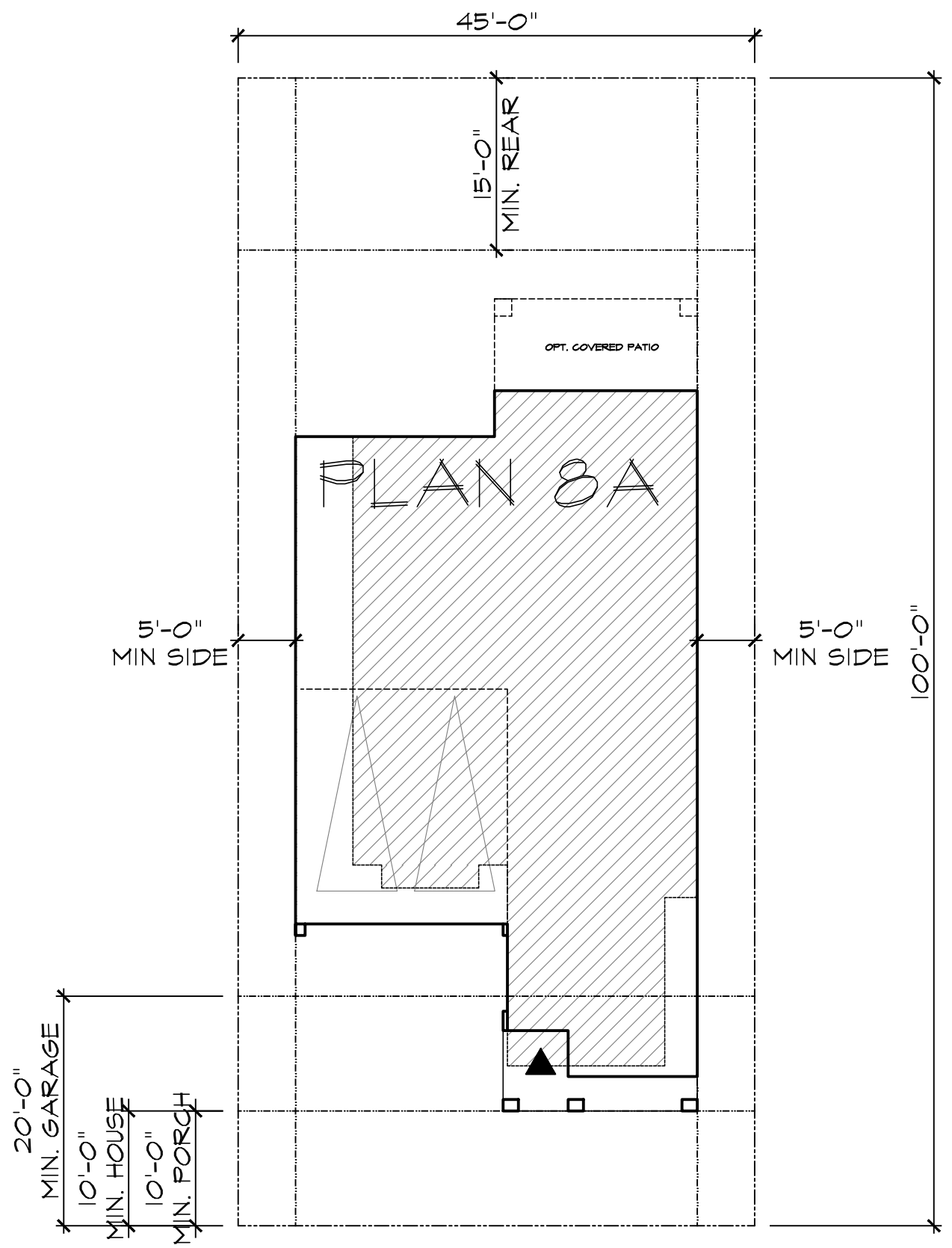

City of Brentwood
MINIMUM REQUIREMENTS

FRONT SETBACK - TO LIVING	10' MIN.
FRONT SETBACK - TO GARAGE	20' MIN.
SIDE YARD - SETBACK	5' MIN.
REAR YARD - SETBACK	15' MIN.
PORCH SETBACK	10' MIN.
LOT SIZE	4,500 SQ. FT.
MAX COVERAGE - 2-STORY	40%

LOT COVERAGE
2-STORY: 40% max

TYPICAL LOT SIZES	FOOTPRINT	APPROX. COVERAGE
45' x 100' = 4,500 SQ. FT.	1,829 SQ. FT.	40%



PLAN 8
Site Plan
STONEBROOK
BRENTWOOD, CA

West Coast
HOME BUILDERS

LEGACY
DESIGN GROUP

DATE JULY 01, 2024

8.2

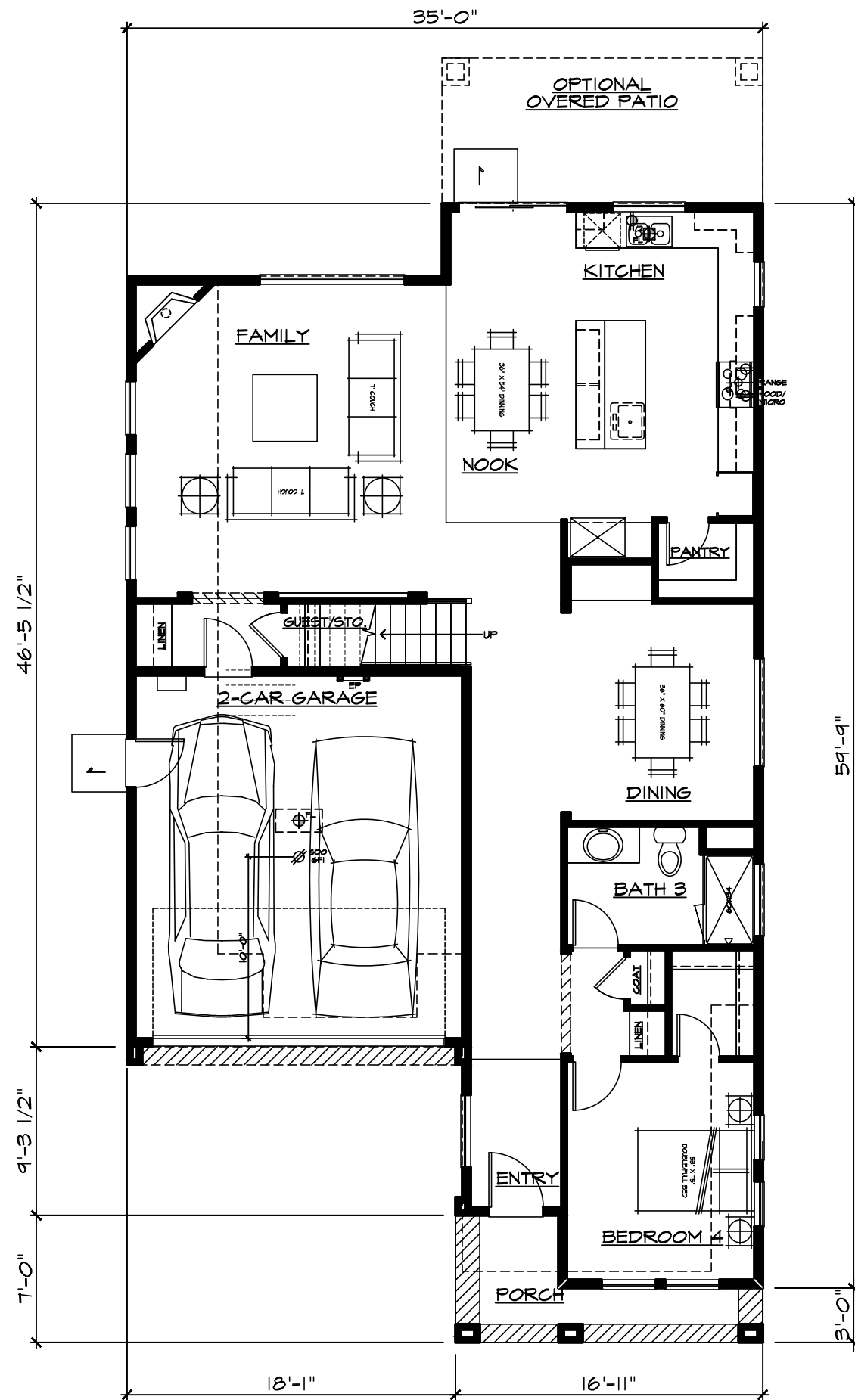

SQUARE FOOTAGE	
FIRST FLOOR	1378 SF
SECOND FLOOR	1394 SF
TOTAL LIVING AREA	2772 SF
<hr/>	
GARAGE	378 SF
PORCH	73 SF
OPT. REAR PATIO	141 SF
FOOTPRINT	1829 SF



PLAN 8

First Floor

STONEBROOK

BRENTWOOD, CA

West Coast
HOME BUILDERS

LEGACY
DESIGN GROUP

DATE JULY 01, 2024

8.3

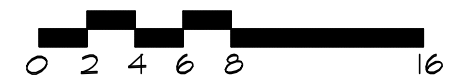
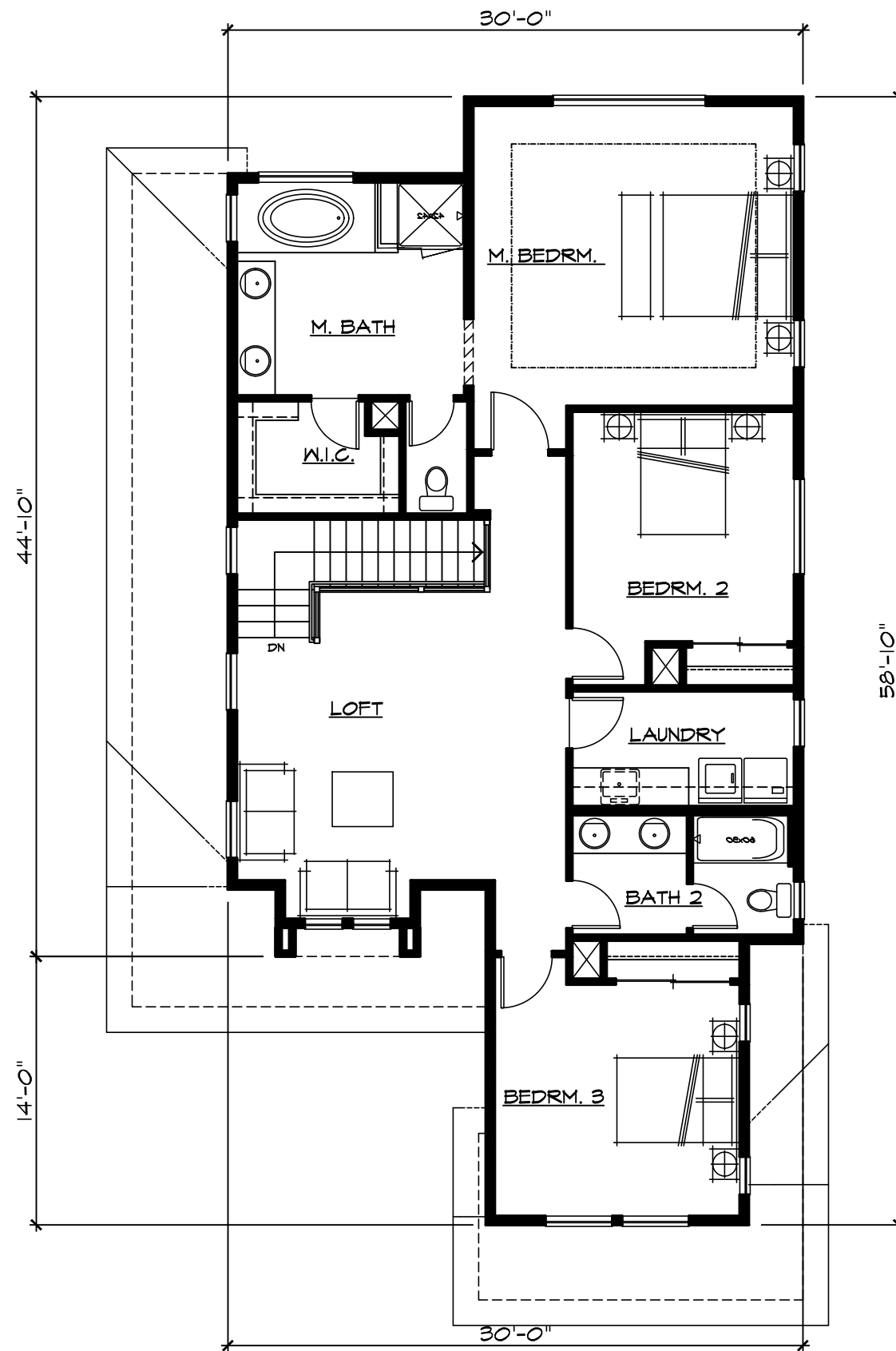

PLAN 8

Second Floor

STONEBROOK

BRENTWOOD, CA

West Coast
HOME BUILDERS

LEGACY
DESIGN GROUP

DATE

JULY 01, 2024

8.4



Right



Front - Tuscan



Left

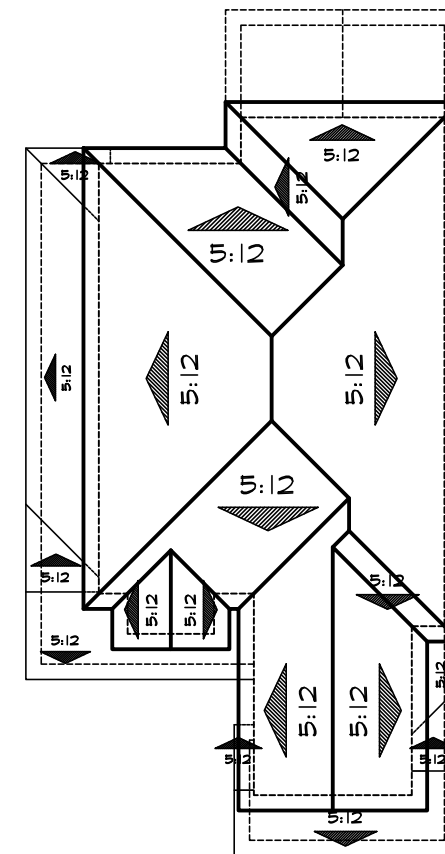

Roof Plan 'A'



--- DENOTES WINDOW GRIDS & TRIM AT SIDE ELEVATIONS FACING STREETS.

PLAN 8
Elevation A
STONEBROOK

BRENTWOOD, CA

West Coast
 HOME BUILDERS

LEGACY
 DESIGN GROUP

DATE JULY 01, 2024

8.5



Rear



Right



Front - French Cottage



Left

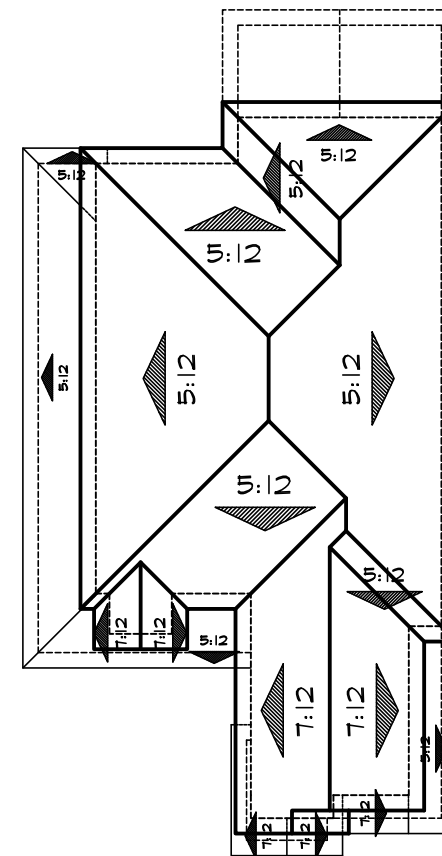

Roof Plan 'B'



--- DENOTES WINDOW GRIDS & TRIM AT SIDE ELEVATIONS FACING STREETS.



Rear

PLAN 8
Elevation B
STONEBROOK

BRENTWOOD, CA

West Coast
 HOME BUILDERS

LEGACY
 DESIGN GROUP

DATE JULY 01, 2024

8.6

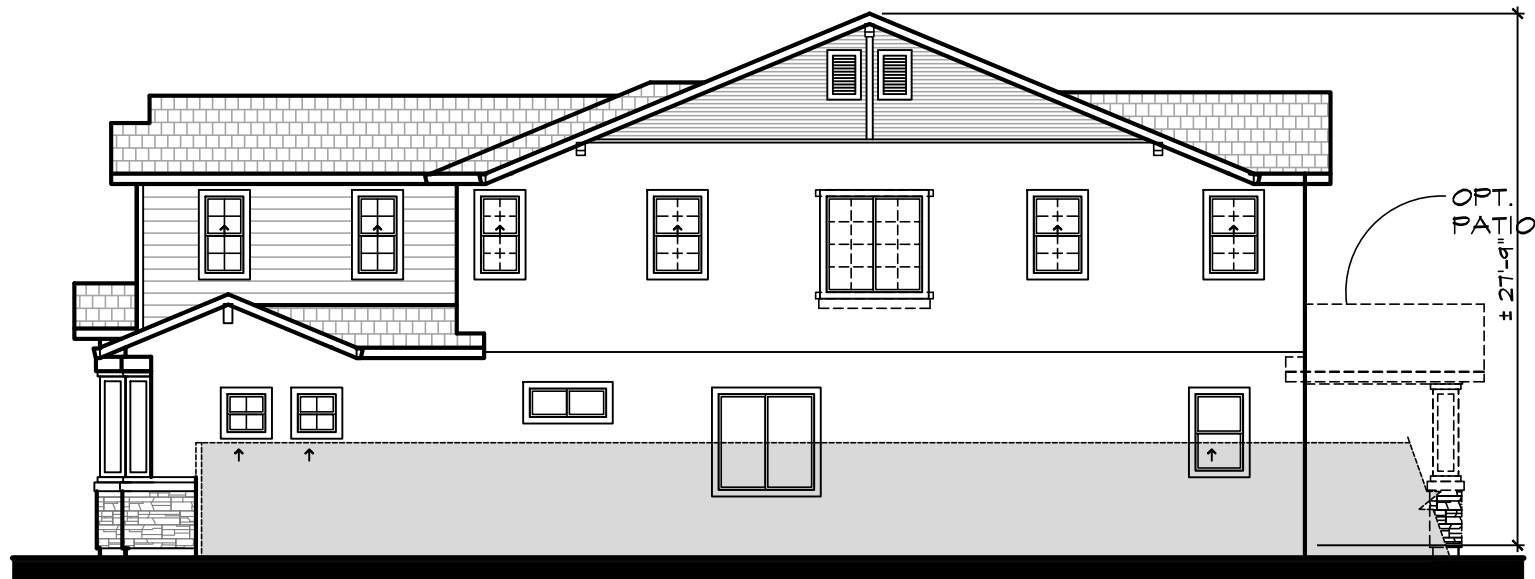

Right



Front - Craftsman

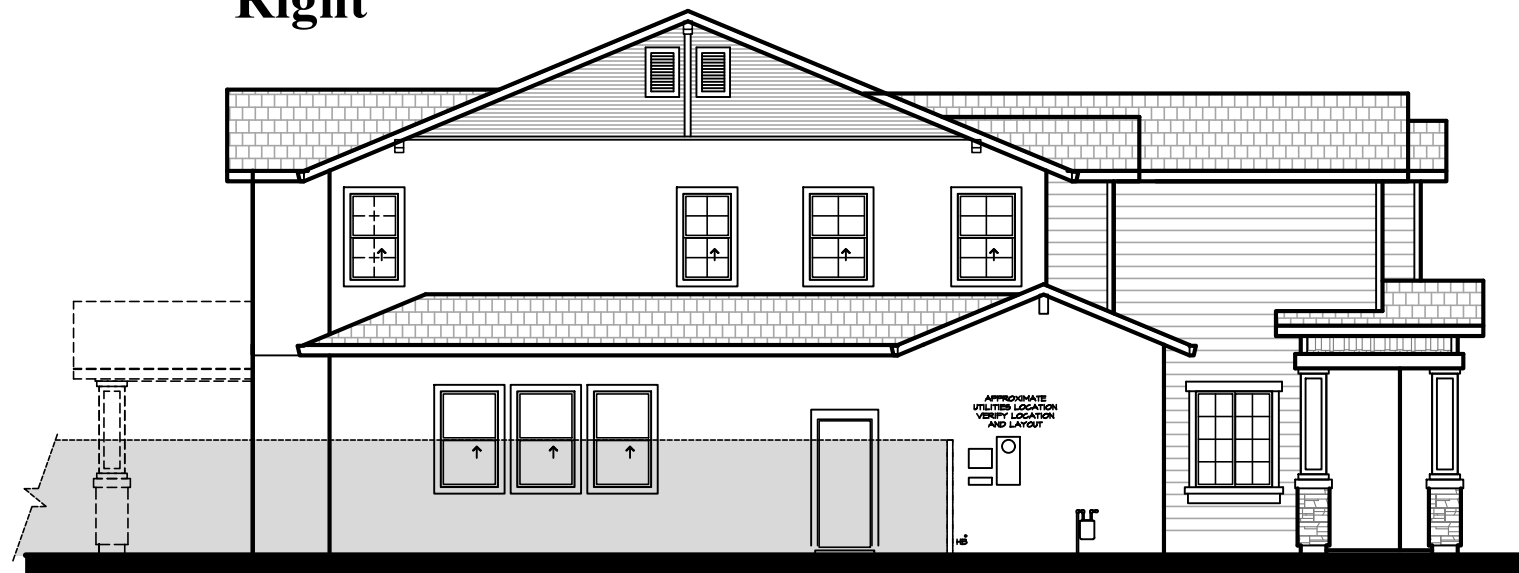
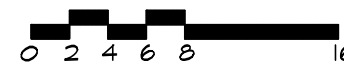

Left

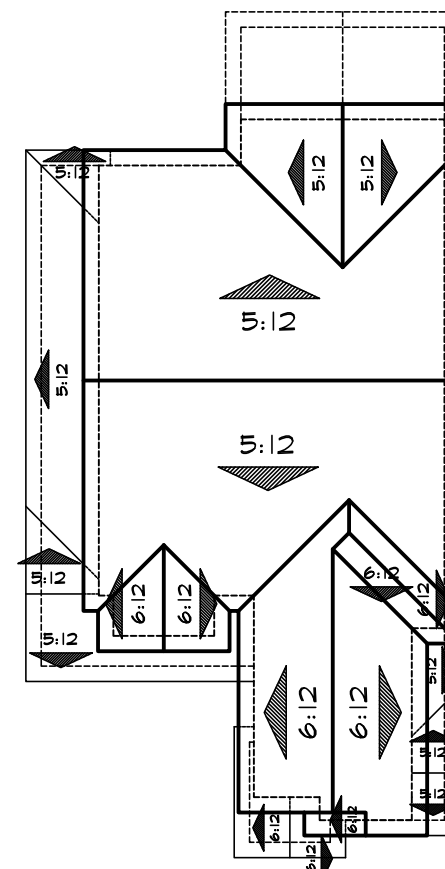

Roof Plan 'C'

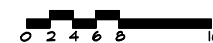

--- DENOTES WINDOW GRIDS & TRIM AT SIDE ELEVATIONS FACING STREETS.



Rear

PLAN 8
Elevation C
STONEBROOK

BRENTWOOD, CA

West Coast
 HOME BUILDERS

LEGACY
DESIGN GROUP

DATE JULY 01, 2024

8.7

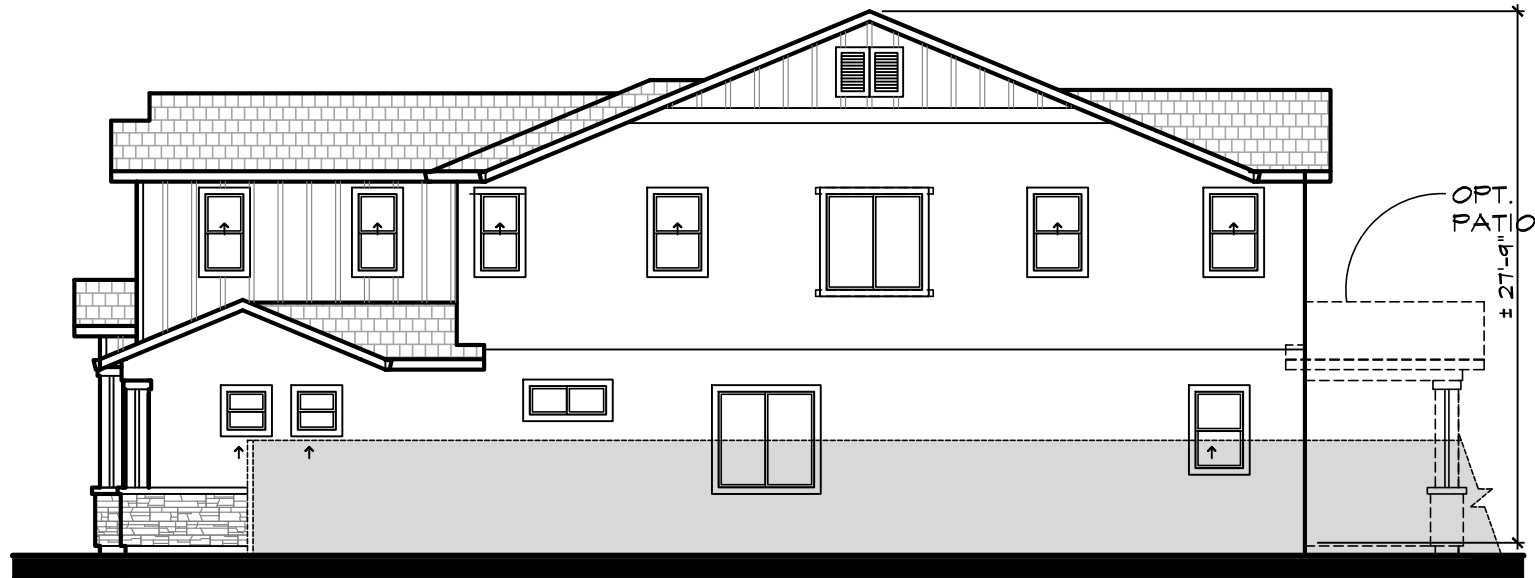

Right



Front - Bay Area Modern

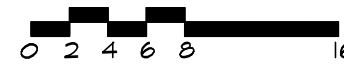

Left

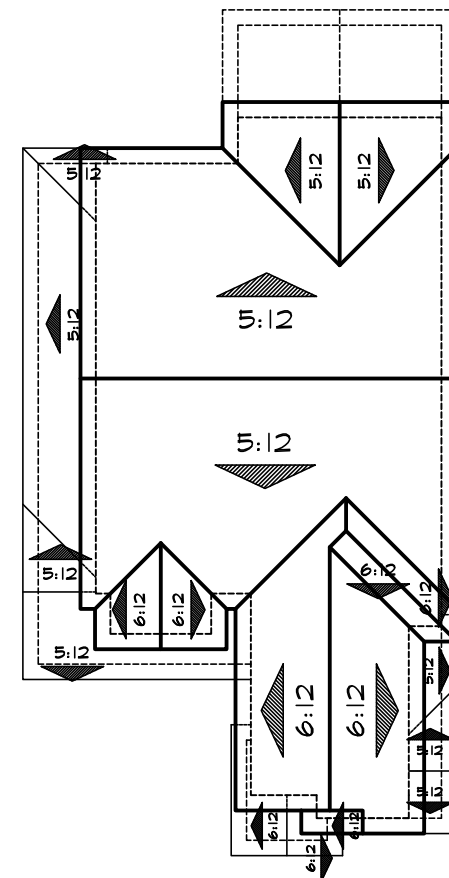

Roof Plan 'D'

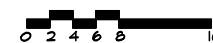

--- DENOTES WINDOW GRIDS & TRIM AT SIDE ELEVATIONS FACING STREETS.



Rear

PLAN 8
Elevation D
STONEBROOK

BRENTWOOD, CA

West Coast
HOME BUILDERS

LEGACY
DESIGN GROUP

DATE JULY 01, 2024

8.8



Elevation A - Tuscan



Elevation B - French Cottage

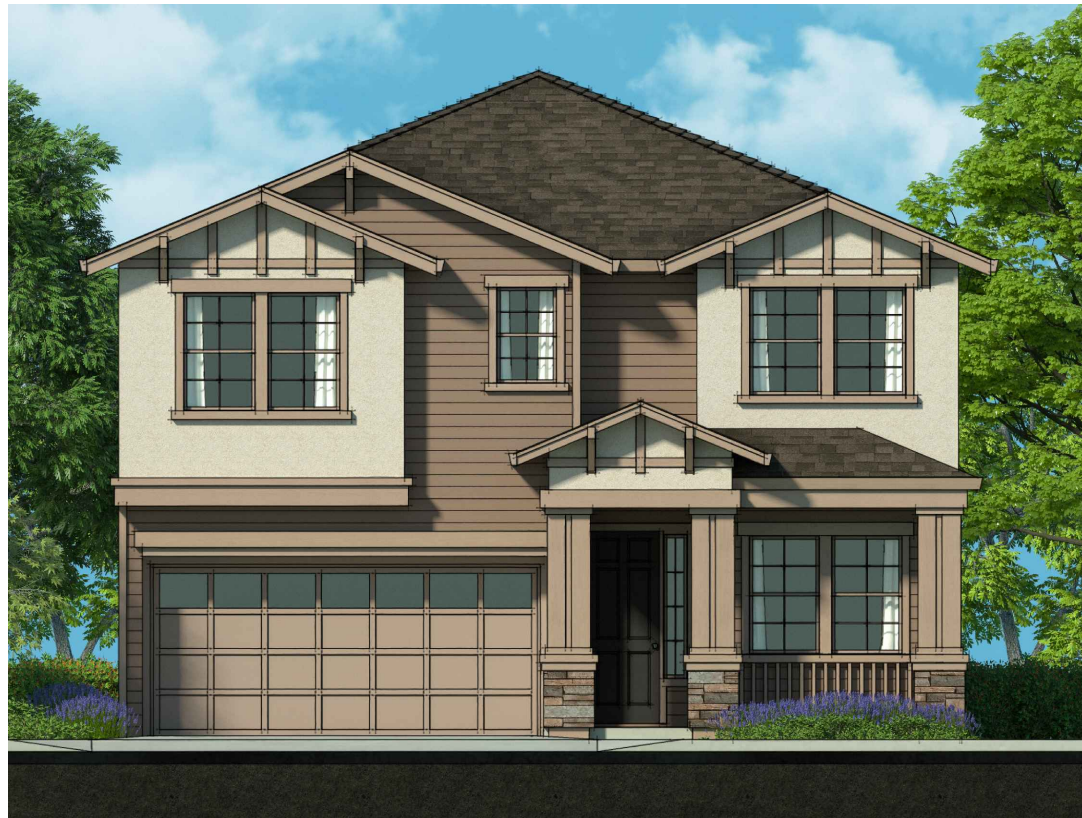

Elevation C - Craftsman



Elevation D - Bay Area Modern

MATERIAL LEGEND

- A** VILLA CONCRETE TILE ROOFING
HIP ROOFS
STUCCO BODY
STUCCO/FOAM TRIM
SIMULATED BRICK VENEER
DECORATIVE FOAM
ROLL-UP GARAGE DOORS
W/ OPT. WINDOW LITES
- B** FLAT CONCRETE TILE ROOFING
HIP & GABLE ROOFS
STUCCO BODY
STUCCO/FOAM TRIM
MOCK VENTS
DECORATIVE FOAM
SIMULATED STONE VENEER
MOCK WOOD SHUTTERS
ROLL-UP GARAGE DOORS
W/ OPT. WINDOW LITES
- C** FLAT CONCRETE TILE ROOFING
HIP & GABLE ROOFS
STUCCO BODY
STUCCO/FOAM TRIM
LAP SIDING
DECORATIVE FOAM
SIMULATED STONE VENEER
STUCCO/FOAM CORBELS
WOOD RAILING
ROLL-UP GARAGE DOORS
W/ OPT. WINDOW LITES
- D** FLAT CONCRETE TILE ROOFING
GABLE ROOFS
STUCCO BODY
STUCCO/FOAM TRIM
BOARD & BATTEN
MOCK VENTS
SIMULATED STONE VENEER
WOOD KICKERS
ROLL-UP GARAGE DOORS
W/ OPT. WINDOW LITES

PLAN 9
Front Elevations
STONEBROOK

BRENTWOOD, CA

West Coast
HOME BUILDERS

LEGACY
DESIGN GROUP

DATE

JULY 01, 2024

9.1

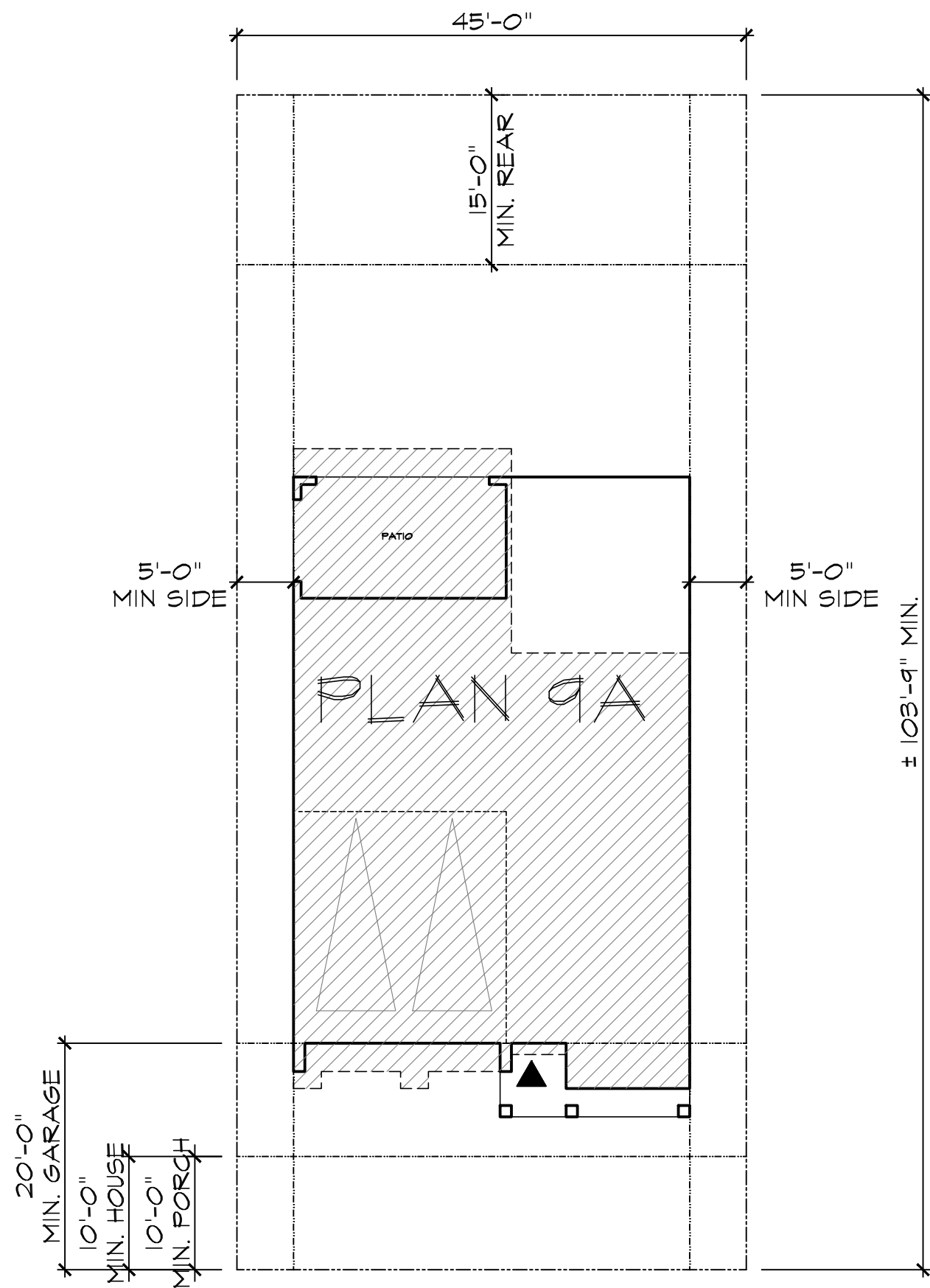

City of Brentwood

MINIMUM REQUIREMENTS

FRONT SETBACK - TO LIVING	10' MIN.
FRONT SETBACK - TO GARAGE	20' MIN.
SIDE YARD - SETBACK	5' MIN.
REAR YARD - SETBACK	15' MIN.
PORCH SETBACK	10' MIN.
LOT SIZE	4,500 SQ. FT.
MAX COVERAGE - 2-STORY	40%

LOT COVERAGE		
2-STORY: 40% max		
TYPICAL LOT SIZES	FOOTPRINT	APPROX. COVERAGE
45' x 103'-9" = 4,668 SQ. FT.	1,858 SQ. FT.	40%



PLAN 9

Site Plan

STONEBROOK

BRENTWOOD, CA

West Coast
HOME BUILDERS

LEGACY
DESIGN GROUP

DATE JULY 01, 2024

9.2

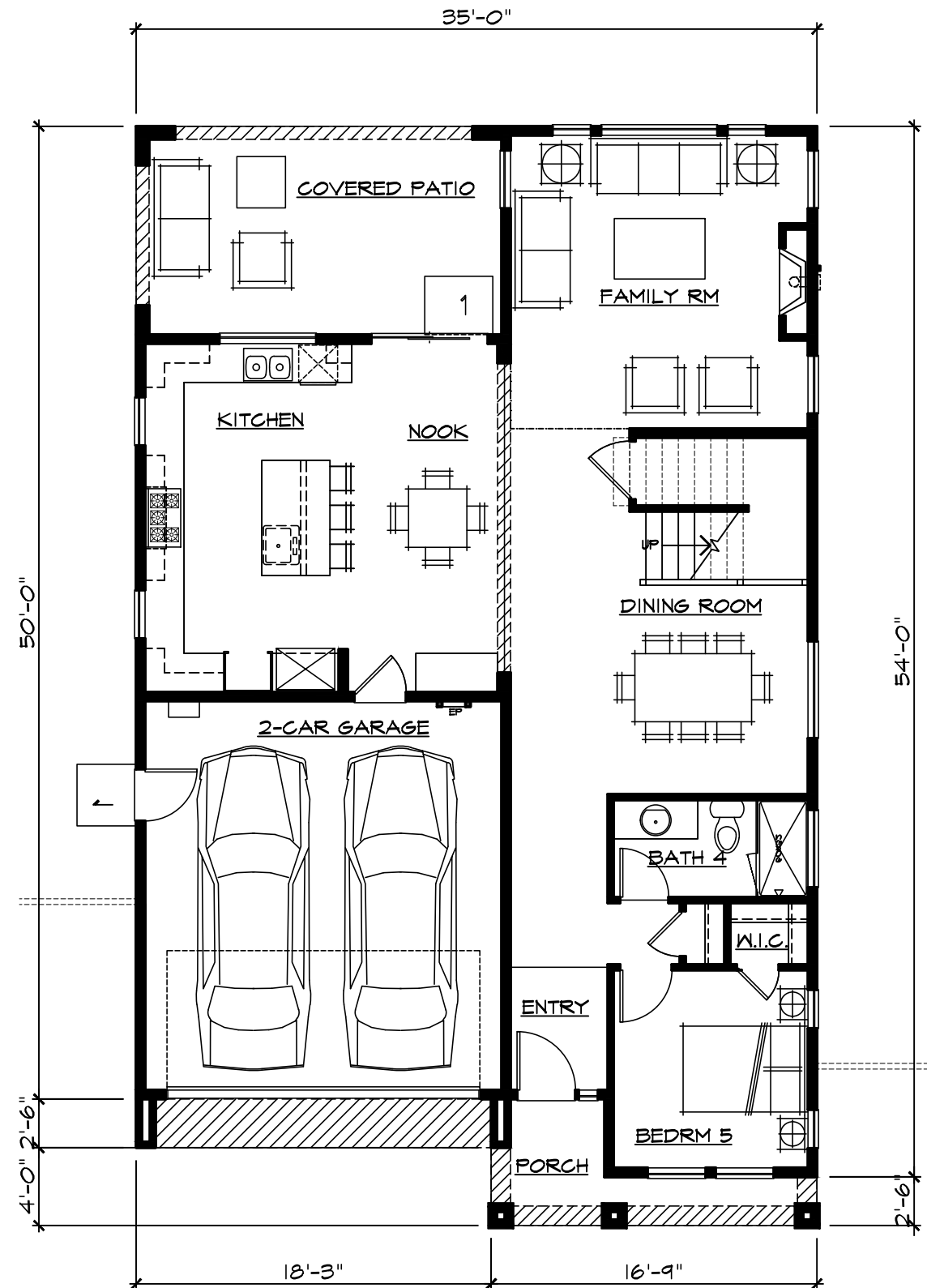

SQUARE FOOTAGE	
FIRST FLOOR	1208 SF
SECOND FLOOR	1579 SF
TOTAL LIVING AREA	2787 SF
GARAGE	384 SF
PORCH	65 SF
COVER PATIO	201 SF
FOOTPRINT W/ PATIO	1858 SF



PLAN 9

First Floor

STONEBROOK

BRENTWOOD, CA

West Coast
HOME BUILDERS

LEGACY
DESIGN GROUP

DATE JULY 01, 2024

9.3

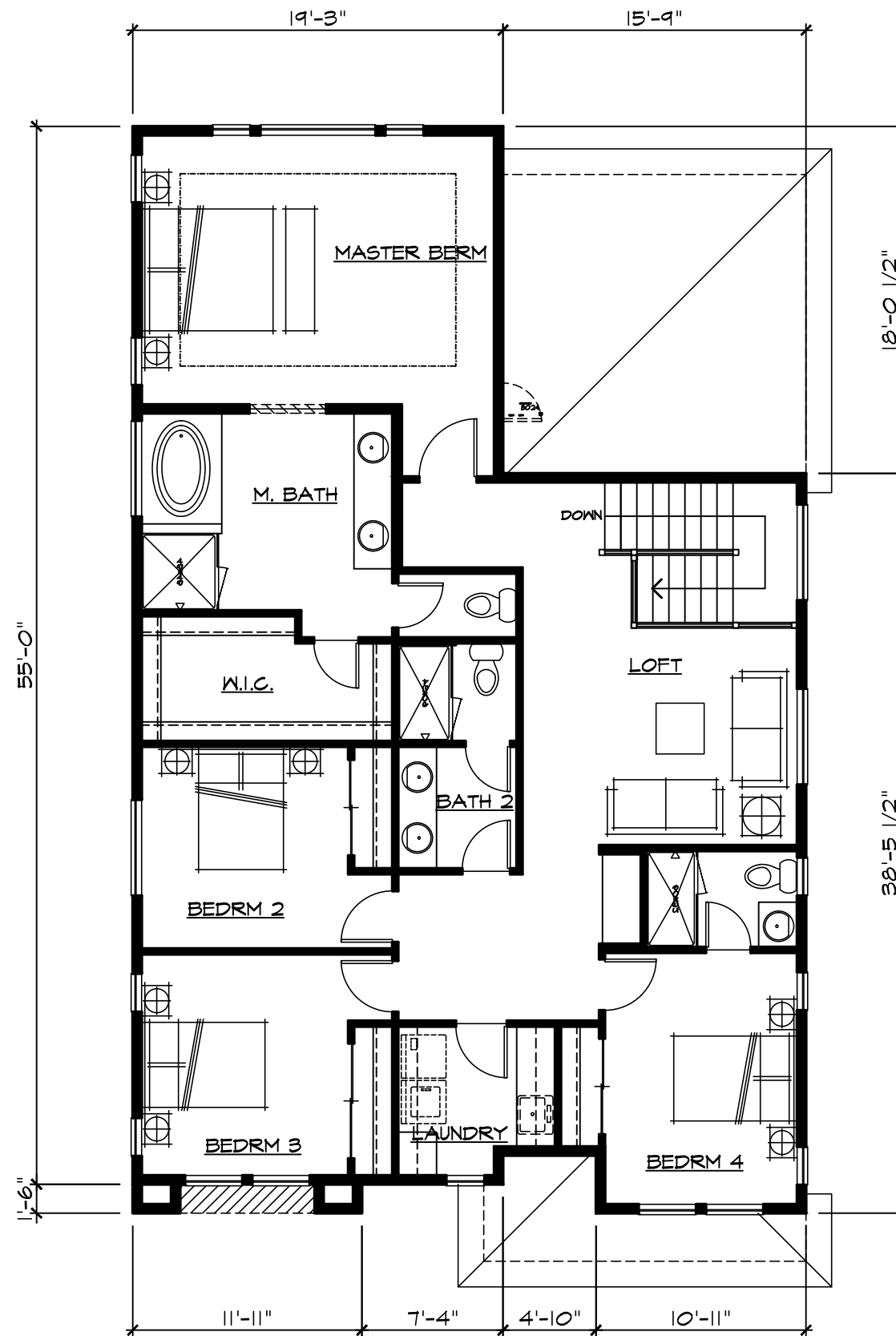

PLAN 9

Second Floor

STONEBROOK

BRENTWOOD, CA

West Coast
HOME BUILDERS

LEGACY
DESIGN GROUP

DATE JULY 01, 2024

9.4



Right



Front - Tuscan



Left

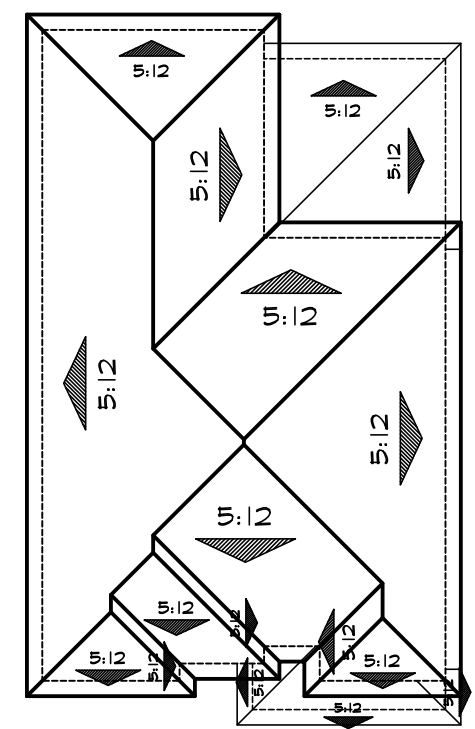

--- DENOTES WINDOW GRIDS & TRIM AT SIDE ELEVATIONS FACING STREETS.



Rear

Roof Plan 'A'

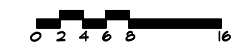

PLAN 9
Elevation A
STONEBROOK

BRENTWOOD, CA

West Coast
 HOME BUILDERS

LEGACY
DESIGN GROUP

DATE JULY 01, 2024

9.5

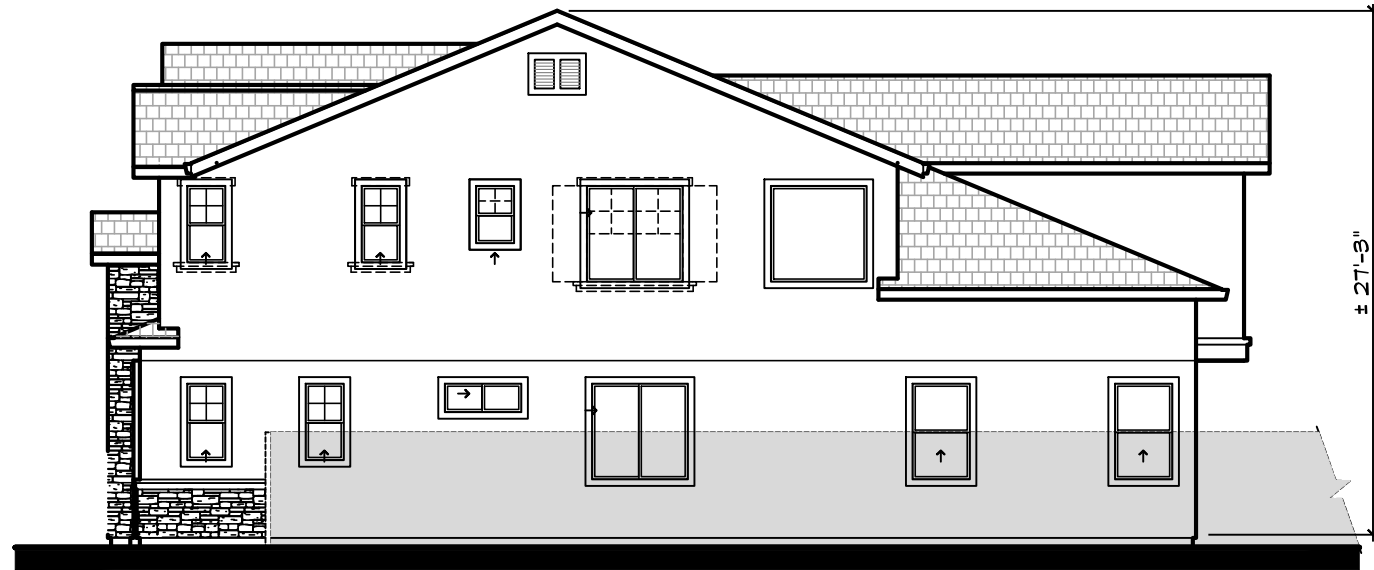

Right



Front - French Cottage

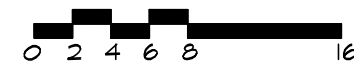

Left

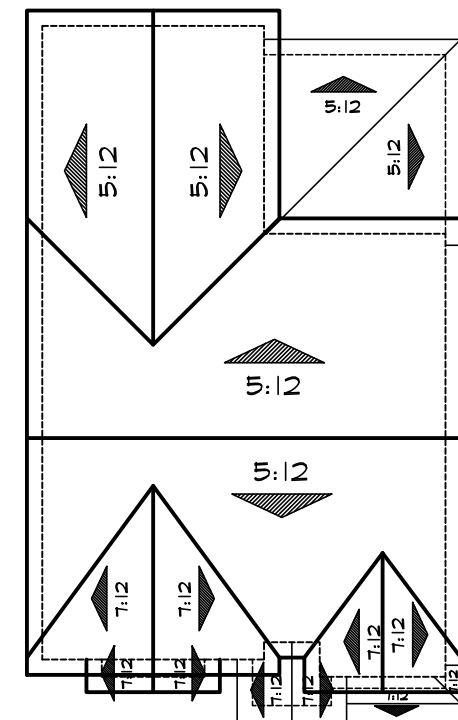

Roof Plan 'B'

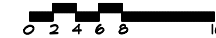

--- DENOTES WINDOW GRIDS, TRIM, & SHUTTERS AT SIDE ELEVATIONS FACING STREETS.



Rear

PLAN 9
Elevation B
STONEBROOK

BRENTWOOD, CA

West Coast
HOME BUILDERS

LEGACY
DESIGN GROUP

DATE JULY 01, 2024

9.6



Right

± 27'-3"



Front - Craftsman

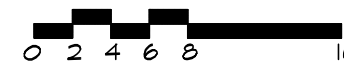

Left

APPROXIMATE UTILITIES LOCATION VERIFY LOCATION AND LAYOUT



Rear

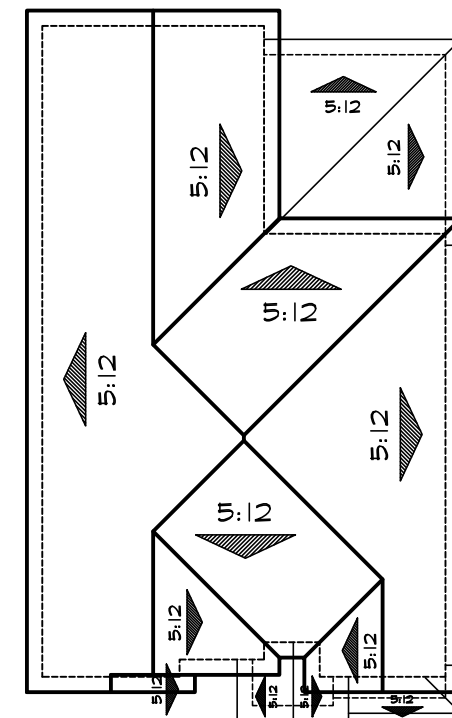

Roof Plan 'C'



--- DENOTES WINDOW GRIDS & TRIM AT SIDE ELEVATIONS FACING STREETS.

PLAN 9
Elevation C
STONEBROOK

BRENTWOOD, CA

West Coast
HOME BUILDERS

LEGACY
DESIGN GROUP

DATE JULY 01, 2024

9.7

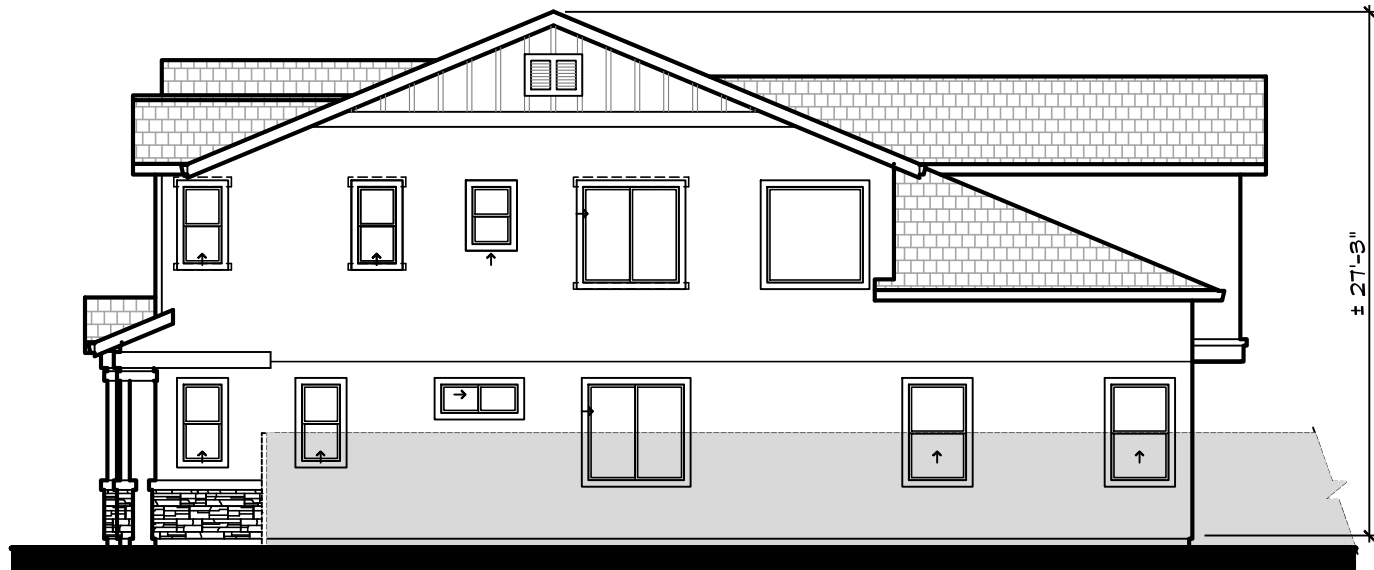

Right



Front - Bay Area Modern



Left

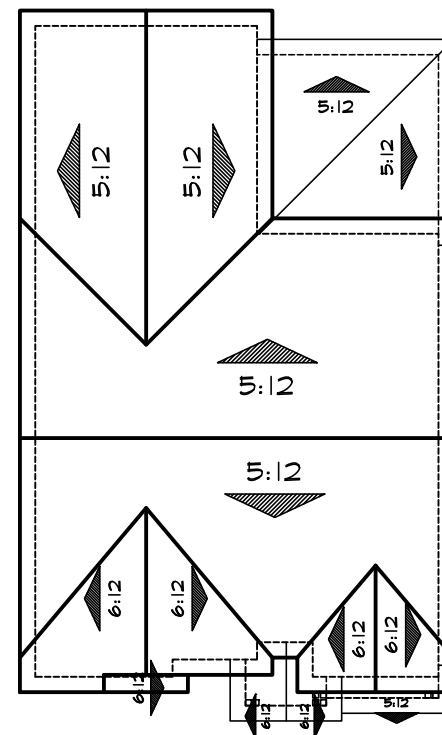

Roof Plan 'D'



--- DENOTES WINDOW GRIDS AT SIDE ELEVATIONS FACING STREETS.



Rear

PLAN 9
Elevation D
STONEBROOK

BRENTWOOD, CA

West Coast
 HOME BUILDERS

LEGACY
 DESIGN GROUP

DATE JULY 01, 2024

9.8



Elevation A - Tuscan



Elevation B - French Cottage



Elevation C - Craftsman

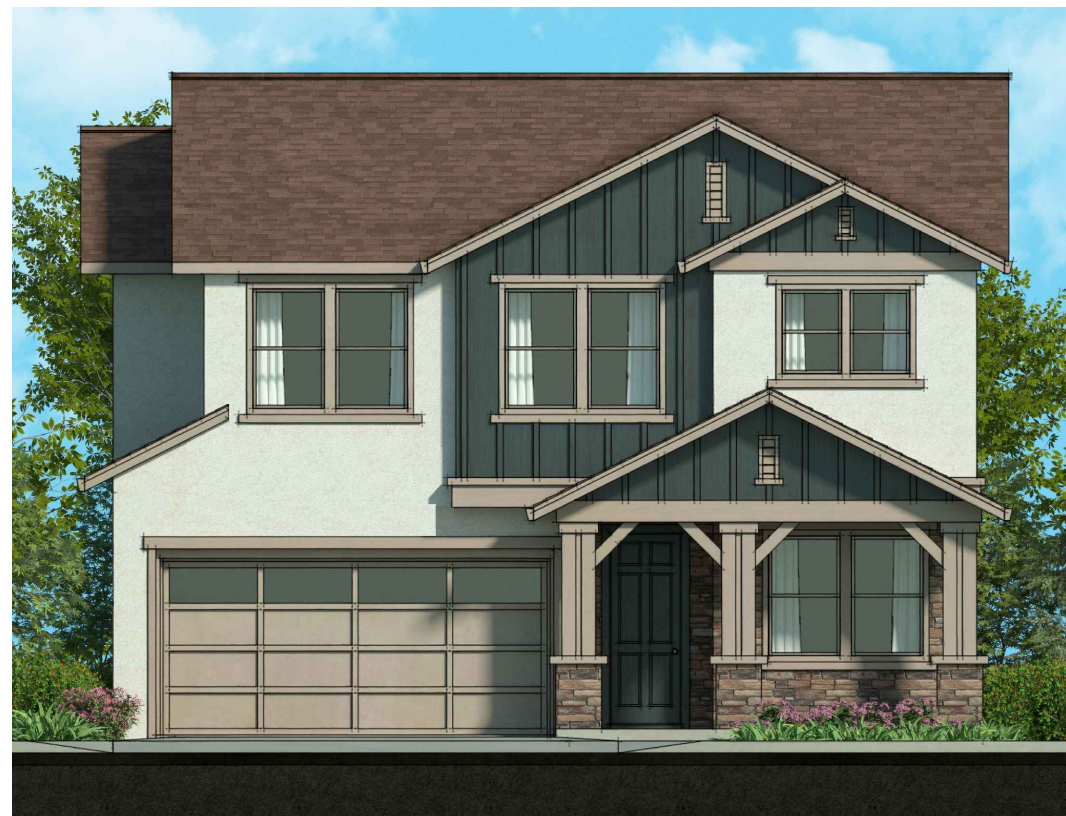

Elevation D - Bay Area Modern

MATERIAL LEGEND

- | | |
|--|---|
| <p>A VILLA CONCRETE TILE ROOFING
HIP & GABLE ROOFS
STUCCO BODY
STUCCO/FOAM TRIM
SIMULATED BRICK VENEER
DECORATIVE FOAM
WOOD KICKERS
DECORATIVE WROUGHT IRON
ROLL-UP GARAGE DOORS
W/ OPT. WINDOW LITES</p> | <p>B FLAT CONCRETE TILE ROOFING
HIP & GABLE ROOFS
STUCCO BODY
STUCCO/FOAM TRIM
MOCK VENTS
DECORATIVE FOAM
SIMULATED STONE VENEER
MOCK WOOD SHUTTERS
ROLL-UP GARAGE DOORS
W/ OPT. WINDOW LITES</p> |
| <p>C FLAT CONCRETE TILE ROOFING
GABLE ROOFS
STUCCO BODY
STUCCO/FOAM TRIM
LAP SIDING
DECORATIVE FOAM
STUCCO/FOAM CORBELS
WOOD RAILING
ROLL-UP GARAGE DOORS
W/ OPT. WINDOW LITES</p> | <p>D FLAT CONCRETE TILE ROOFING
GABLE ROOFS
STUCCO BODY
STUCCO/FOAM TRIM
BOARD & BATTEN
WOOD KICKERS
DECORATIVE FOAM
MOCK VENTS
SIMULATED STONE VENEER
ROLL-UP GARAGE DOORS
W/ OPT. WINDOW LITES</p> |

PLAN 10
Front Elevations
STONEBROOK

BRENTWOOD, CA

West Coast
HOME BUILDERS

LEGACY
DESIGN GROUP

DATE JULY 01, 2024

10.1

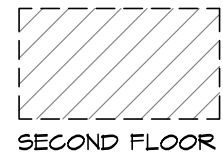
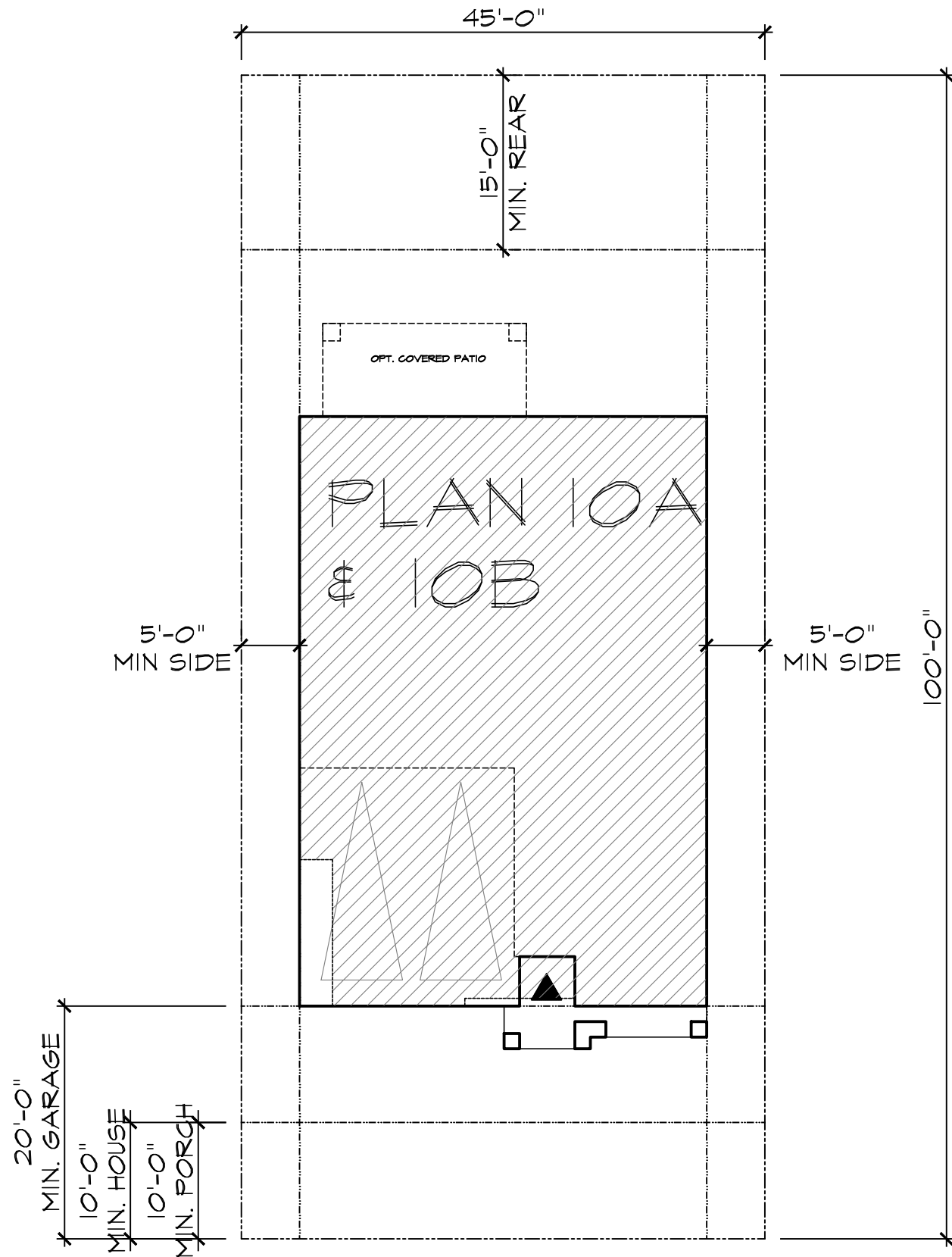

City of Brentwood
MINIMUM REQUIREMENTS

FRONT SETBACK - TO LIVING	10' MIN.
FRONT SETBACK - TO GARAGE	20' MIN.
SIDE YARD - SETBACK	5' MIN.
REAR YARD - SETBACK	15' MIN.
PORCH SETBACK	10' MIN.
LOT SIZE -	4,500 SQ. FT.
MAX COVERAGE - 2-STORY	40%

LOT COVERAGE		
2-STORY: 40% max		
TYPICAL LOT SIZES	FOOTPRINT	APPROX. COVERAGE
45' x 100' = 4,500 SQ. FT.	1,828 SQ. FT.	40%

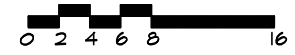

PLAN 10
Site Plan
STONEBROOK
BRENTWOOD, CA

West Coast
HOME BUILDERS
LEGACY
DESIGN GROUP
DATE JULY 01, 2024

10.2

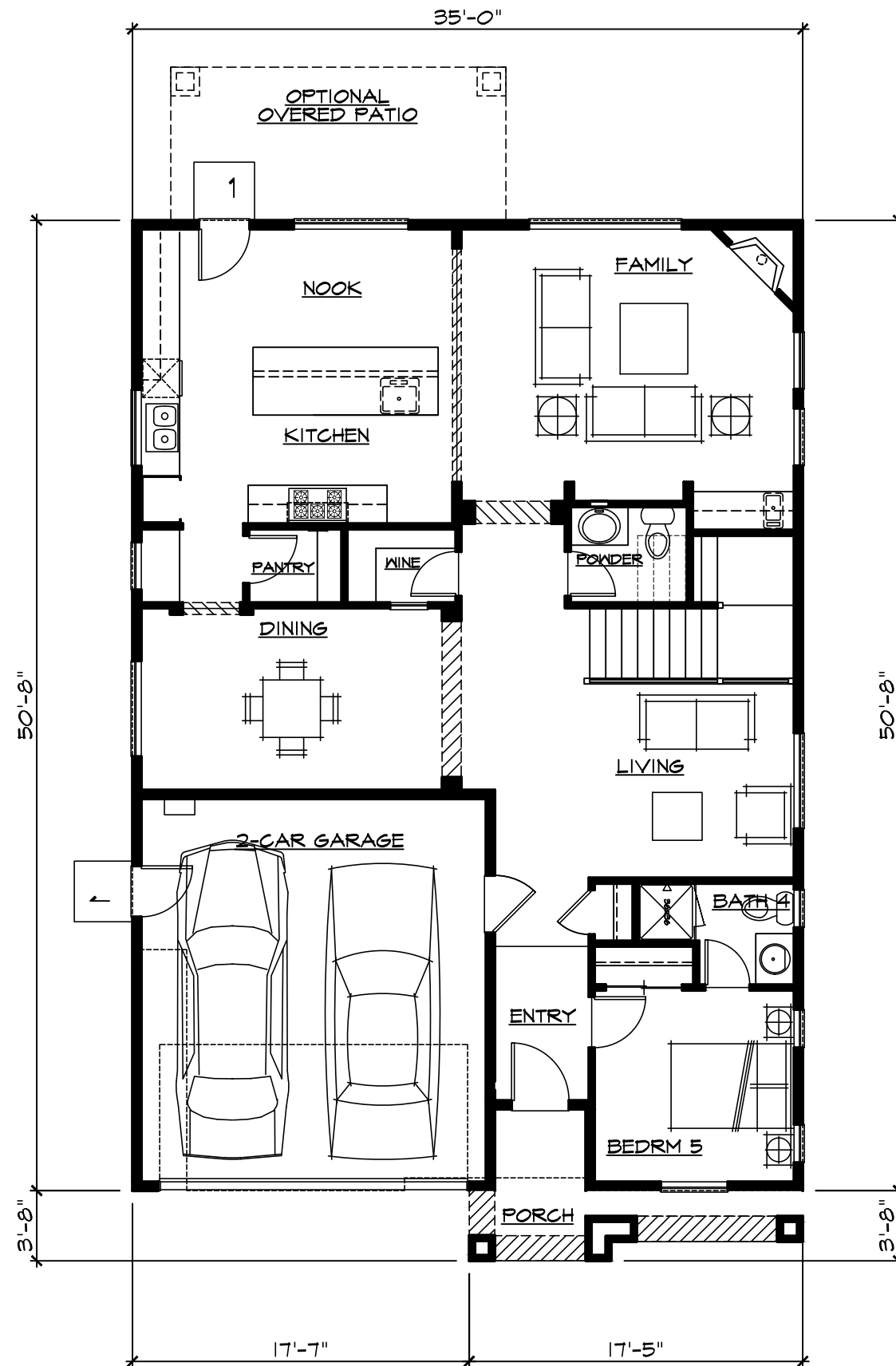

SQUARE FOOTAGE	
FIRST FLOOR	1374 SF
SECOND FLOOR	1414 SF
TOTAL LIVING AREA	2788 SF
<hr/>	
GARAGE	380 SF
PORCH	74 SF
OPT. REAR PATIO	140 SF
FOOTPRINT	1828 SF



PLAN 10

First Floor

STONEBROOK

BRENTWOOD, CA

West Coast
HOME BUILDERS

LEGACY
DESIGN GROUP

DATE JULY 01, 2024

10.3

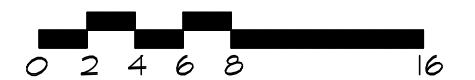
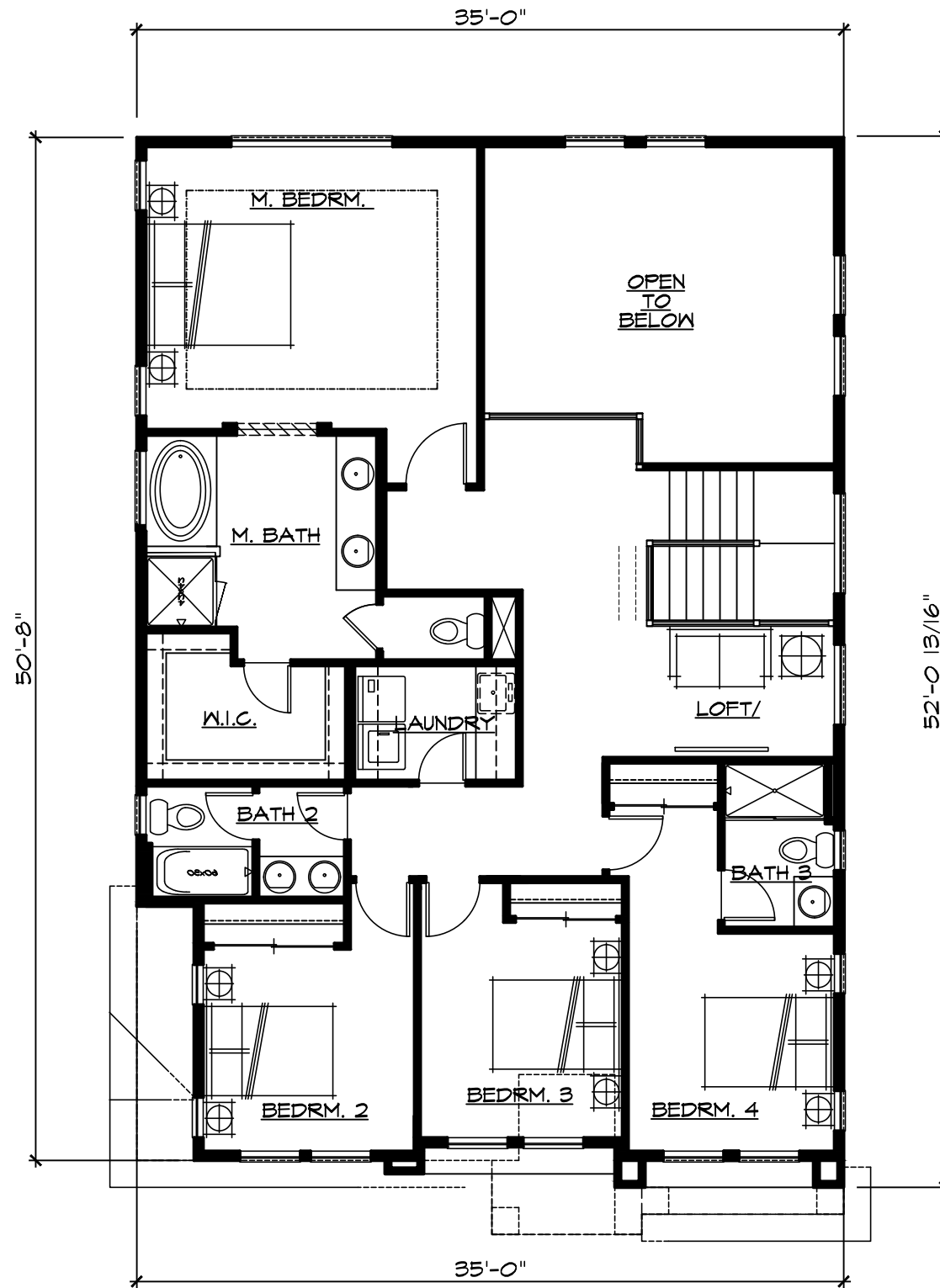

PLAN 10

Second Floor

STONEBROOK

BRENTWOOD, CA

West Coast
HOME BUILDERS

LEGACY
DESIGN GROUP

DATE JULY 01, 2024

10.4



Right



Front - Tuscan

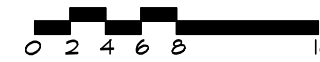

Left

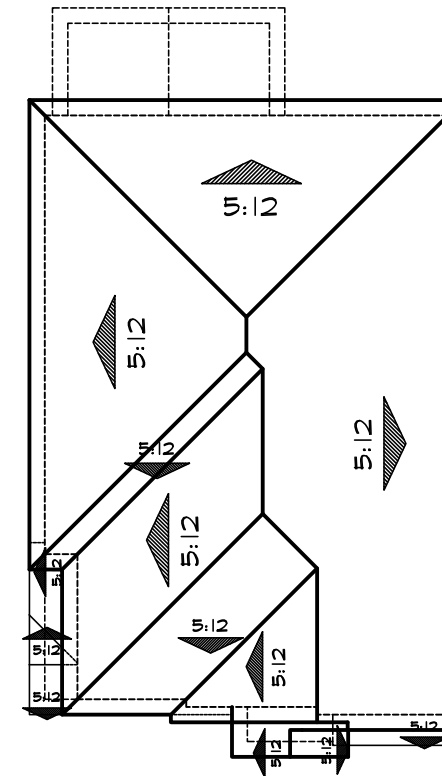

Roof Plan 'A'

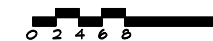

DENOTES WINDOW GRIDS & TRIM AT SIDE ELEVATIONS FACING STREETS.

PLAN 10
Elevation A
STONEBROOK

BRENTWOOD, CA

West Coast
HOME BUILDERS

LEGACY
DESIGN GROUP

DATE JULY 01, 2024

10.5



Rear



Right



Left



Rear



Front - French Cottage

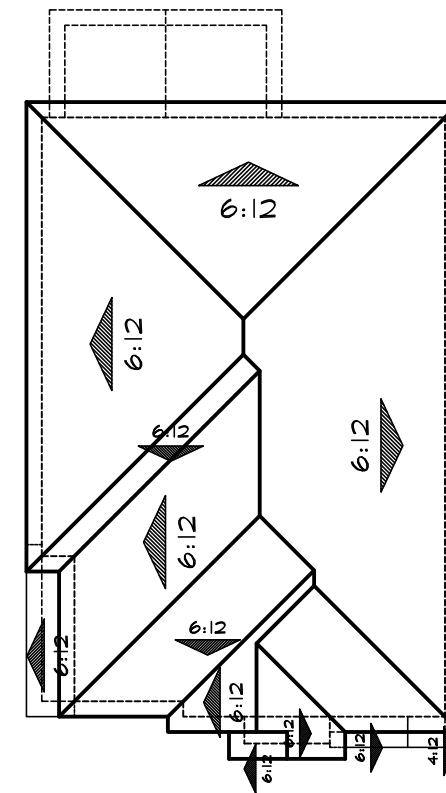

Roof Plan 'B'

--- DENOTES WINDOW GRIDS & TRIM AT SIDE ELEVATIONS FACING STREETS.

PLAN 10
Elevation B
STONEBROOK

BRENTWOOD, CA

West Coast
 HOME BUILDERS

LEGACY
 DESIGN GROUP

DATE JULY 01, 2024

10.6

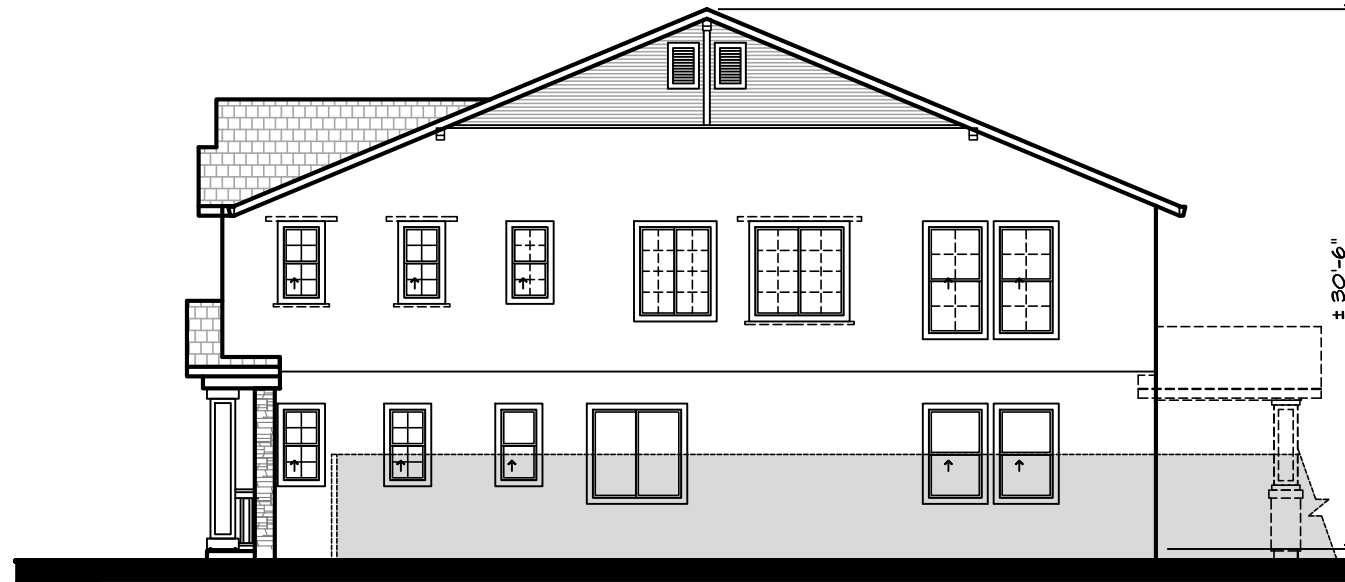

Right

± 30'-6"



Left

APPROXIMATE
UTILITIES LOCATION
VERIFY LOCATION
AND LAYOUT



Rear



Front - Craftsman

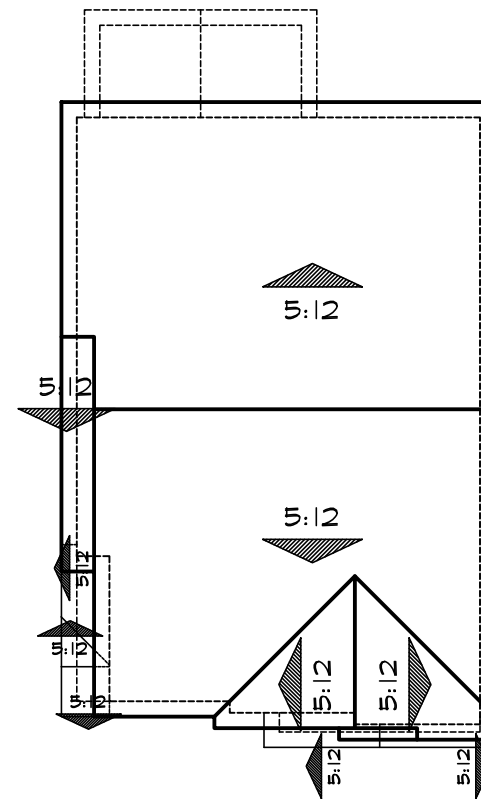

Roof Plan 'C'



--- DENOTES WINDOW GRIDS & TRIM AT
SIDE ELEVATIONS FACING STREETS.

PLAN 10
Elevation C
STONEBROOK

BRENTWOOD, CA

West Coast
HOME BUILDERS

LEGACY
DESIGN GROUP

DATE JULY 01, 2024

10.7

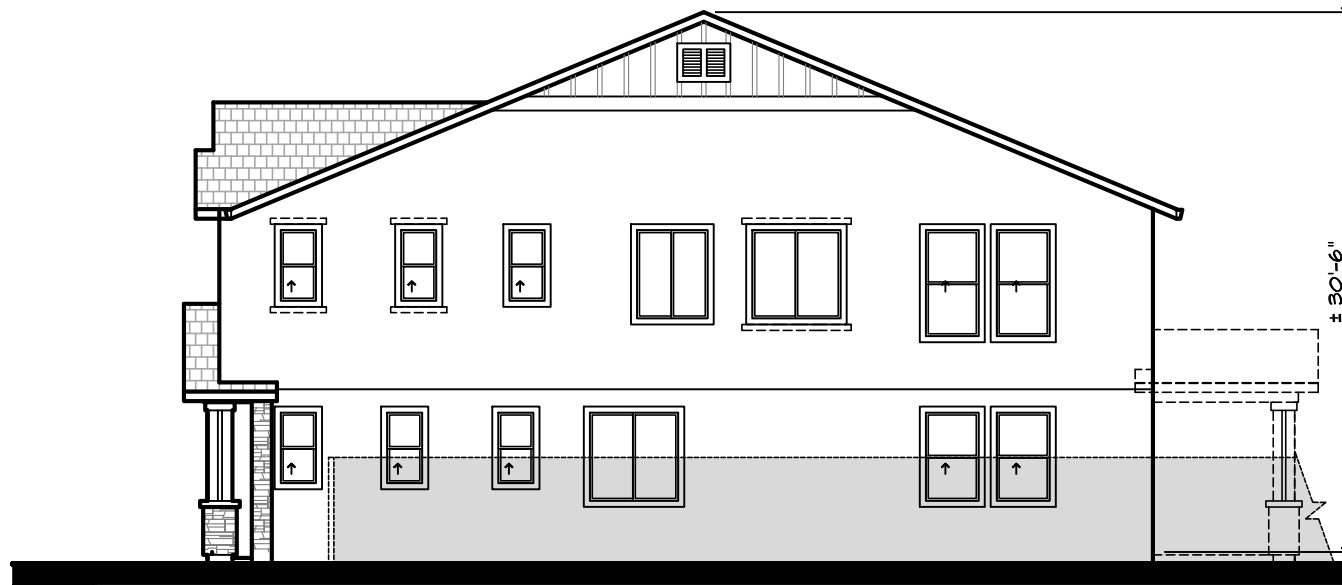

Right



Left



Rear



Front - Bay Area Modern

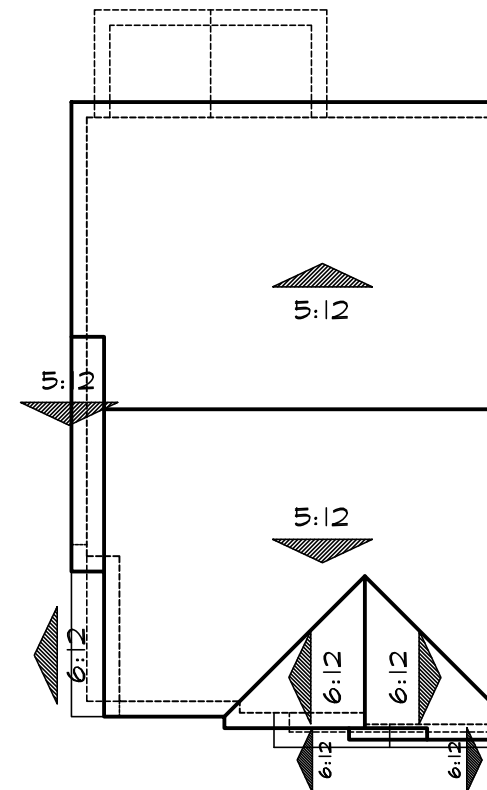
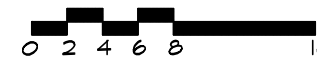

Roof Plan 'D'



--- DENOTES WINDOW GRIDS & TRIM AT SIDE ELEVATIONS FACING STREETS.

PLAN 10
Elevation D
STONEBROOK

BRENTWOOD, CA

West Coast
 HOME BUILDERS

LEGACY
 DESIGN GROUP

DATE JULY 01, 2024

10.8



Elevation A - Tuscan



Elevation B - French Cottage



Elevation C - Craftsman



Elevation D - Bay Area Modern

MATERIAL LEGEND

- | | |
|---|---|
| <p>A VILLA CONCRETE TILE ROOFING
HIP & GABLE ROOFS
STUCCO BODY
STUCCO/FOAM TRIM
SIMULATED STONE VENEER
STUCCO/FOAM CORBELS
DECORATIVE FOAM
ROLL-UP GARAGE DOORS
W/ OPT. WINDOW LITES</p> | <p>B FLAT CONCRETE TILE ROOFING
GABLE ROOFS
STUCCO BODY
STUCCO/FOAM TRIM
MOCK VENTS
DECORATIVE FOAM
SIMULATED STONE VENEER
WOOD RAILING
ROLL-UP GARAGE DOORS
W/ OPT. WINDOW LITES</p> |
| <p>C FLAT CONCRETE TILE ROOFING
HIP & GABLE ROOFS
STUCCO BODY
STUCCO/FOAM TRIM
LAP SIDING
DECORATIVE FOAM
SIMULATED STONE VENEER
STUCCO/FOAM CORBELS
WOOD TRIM
ROLL-UP GARAGE DOORS
W/ OPT. WINDOW LITES</p> | <p>D FLAT CONCRETE TILE ROOFING
GABLE ROOFS
STUCCO BODY
STUCCO/FOAM TRIM
BOARD & BATTEN
MOCK VENTS
SIMULATED STONE VENEER
DECORATIVE FOAM
WOOD KICKERS
ROLL-UP GARAGE DOORS
W/ OPT. WINDOW LITES</p> |

PLAN 11
Front Elevations
STONEBROOK

BRENTWOOD, CA

West Coast
HOME BUILDERS

LEGACY
DESIGN GROUP

DATE JULY 01, 2024

11.1

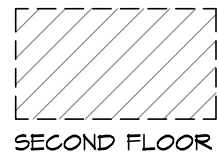
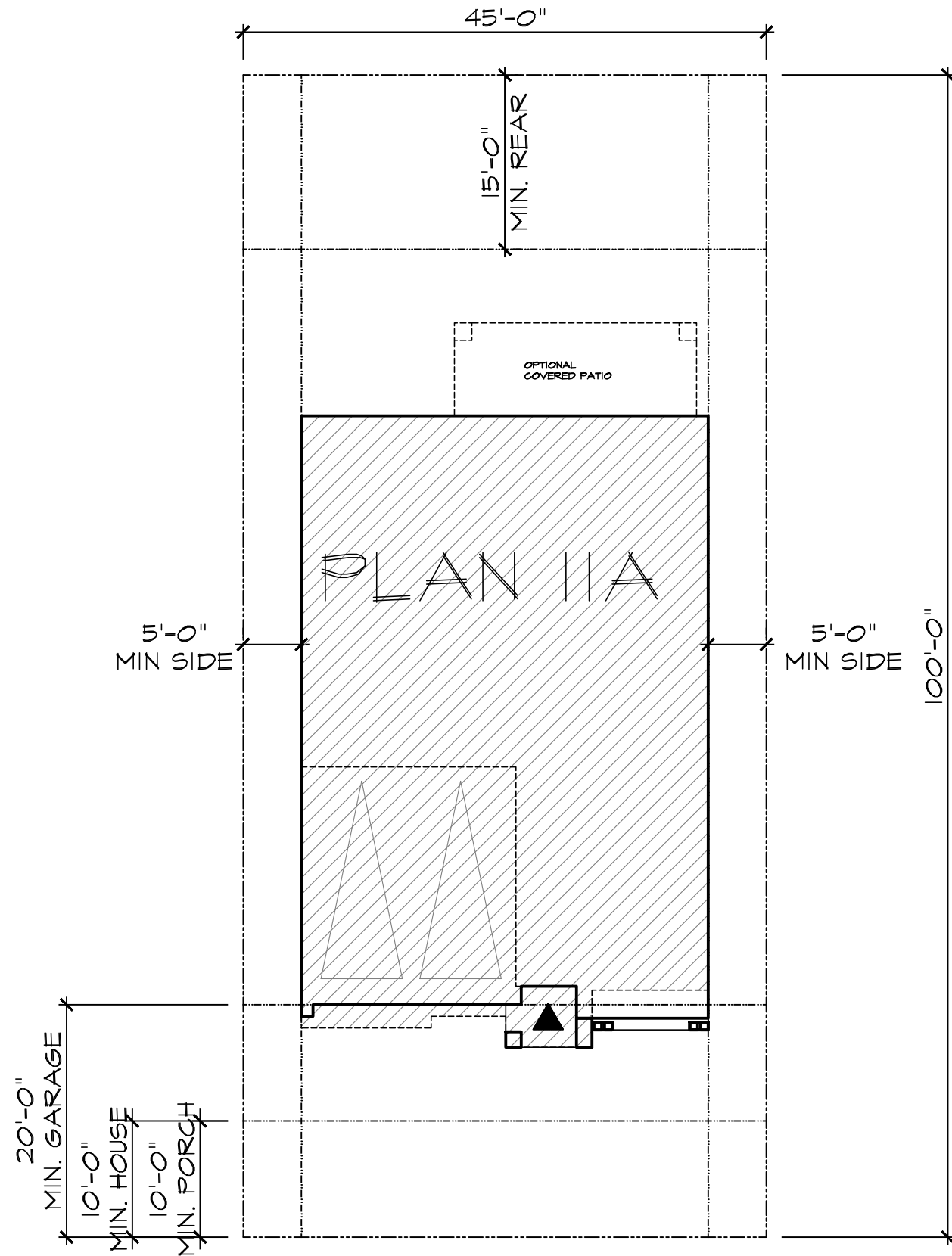

City of Brentwood
MINIMUM REQUIREMENTS

FRONT SETBACK - TO LIVING	10' MIN.
FRONT SETBACK - TO GARAGE	20' MIN.
SIDE YARD - SETBACK	5' MIN.
REAR YARD - SETBACK	15' MIN.
PORCH SETBACK	10' MIN.
LOT SIZE -	4,500 SQ. FT.
MAX COVERAGE - 2-STORY	40%

LOT COVERAGE 2-STORY: 40% max		
TYPICAL LOT SIZES	FOOTPRINT	APPROX. COVERAGE
45' x 100' = 4,500 SQ. FT.	1,822 SQ. FT.	40%

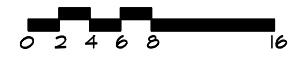

PLAN 11
Site Plan
STONEBROOK

BRENTWOOD, CA

West Coast
HOME BUILDERS

LEGACY
DESIGN GROUP

DATE

JULY 01, 2024

11.2

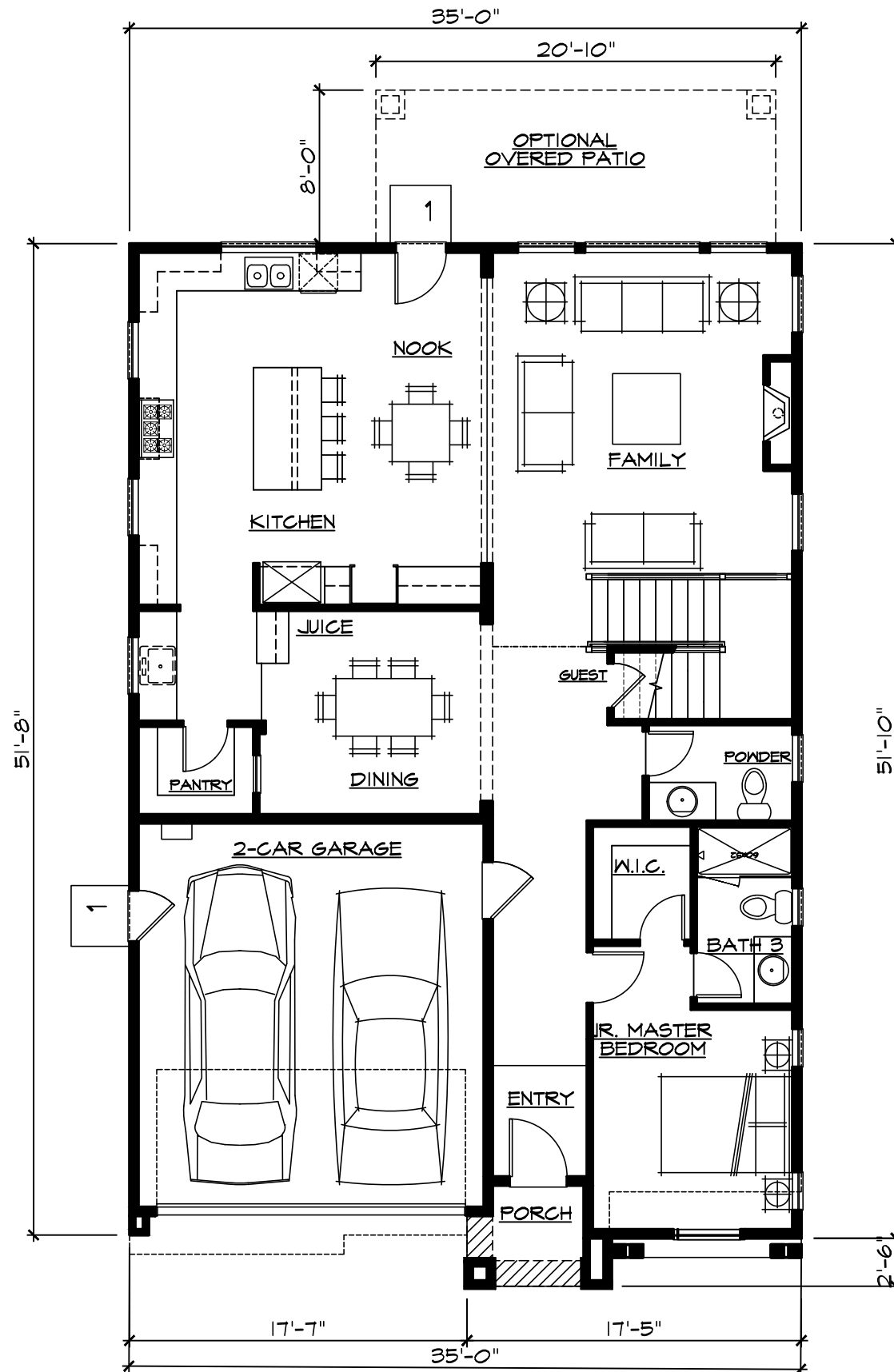

SQUARE FOOTAGE	
FIRST FLOOR	1401 SF
SECOND FLOOR	1430 SF
TOTAL LIVING AREA	2831 SF
<hr/>	
GARAGE	378 SF
PORCH	43 SF
FOOTPRINT	1822 SF

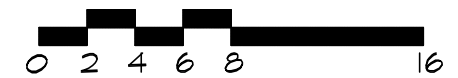

PLAN 11

First Floor

STONEBROOK

BRENTWOOD, CA

West Coast
HOME BUILDERS

LEGACY
DESIGN GROUP

DATE JULY 01, 2024

11.3

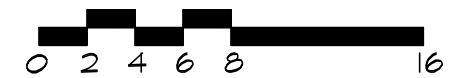
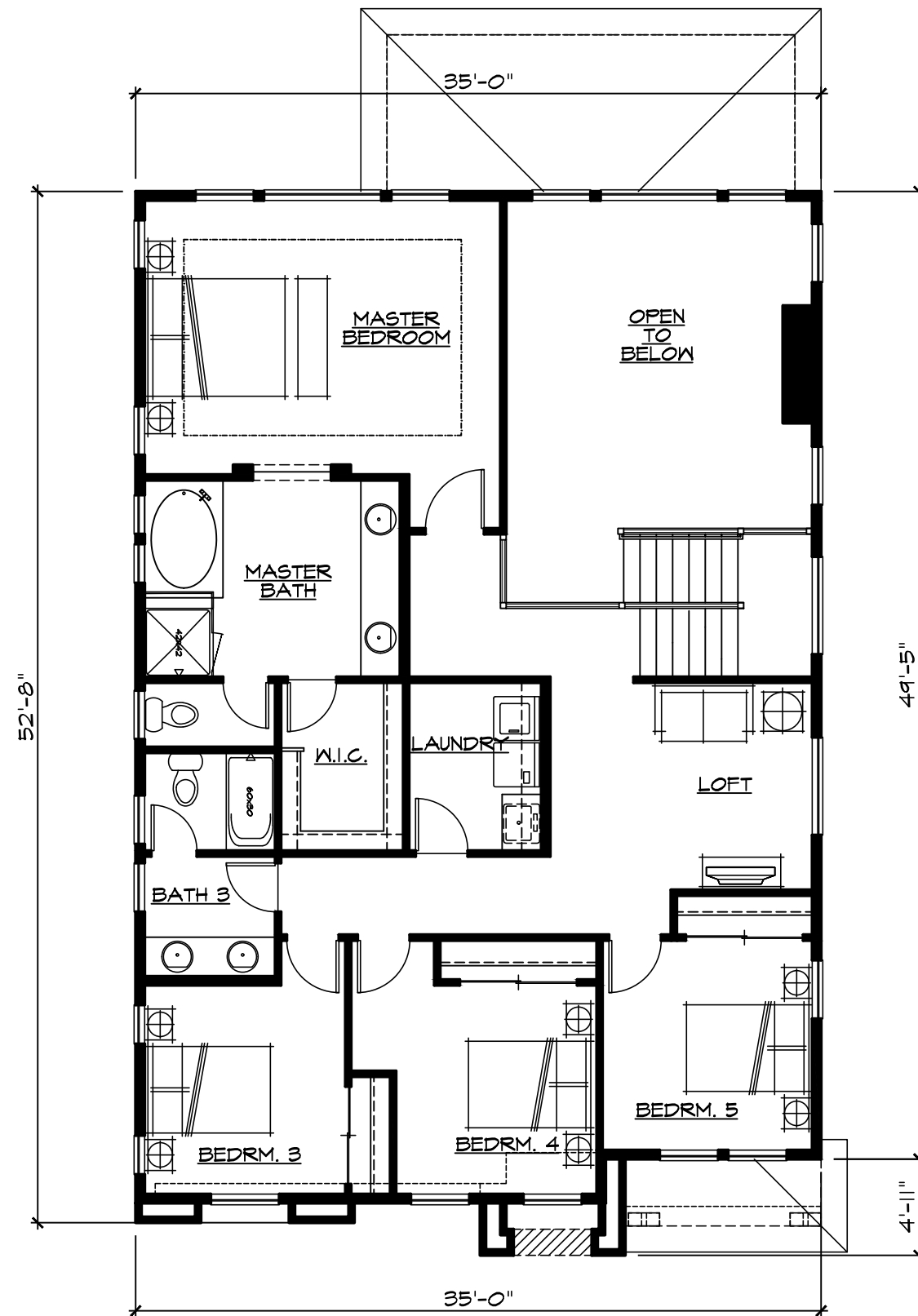

PLAN 11
Second Floor
STONEBROOK

BRENTWOOD, CA

West Coast
 HOME BUILDERS

LEGACY
DESIGN GROUP

DATE JULY 01, 2024

11.4

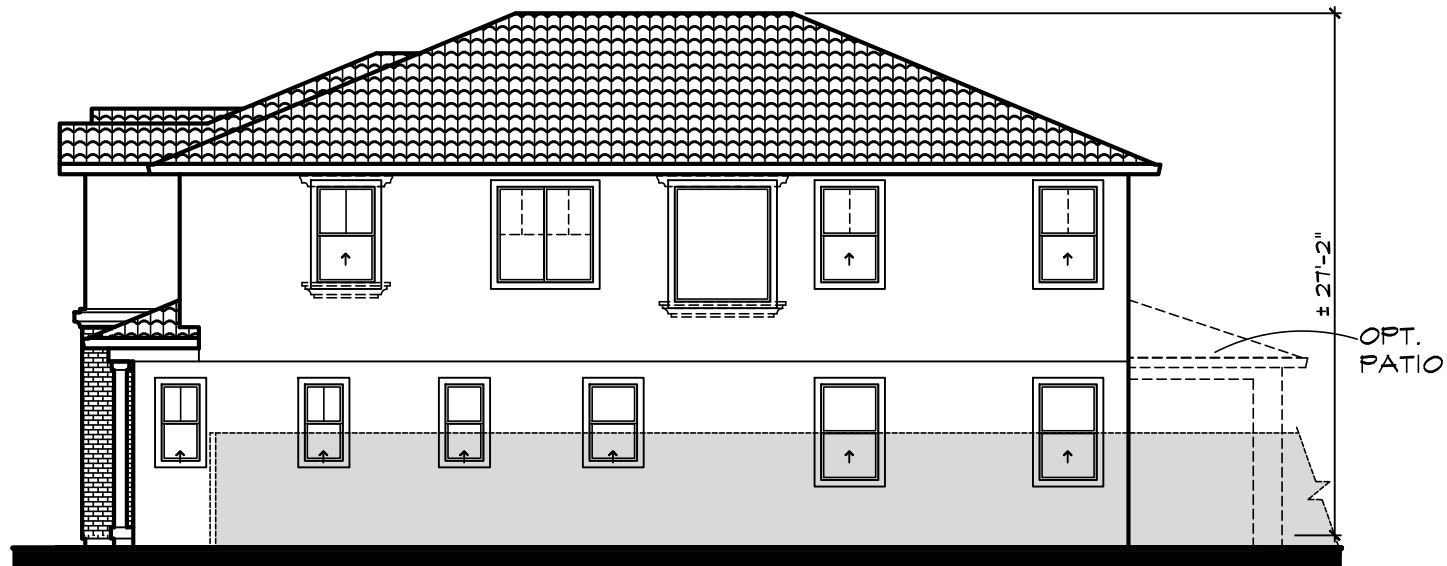

Right



Front - Tuscan

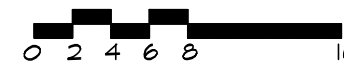

Left

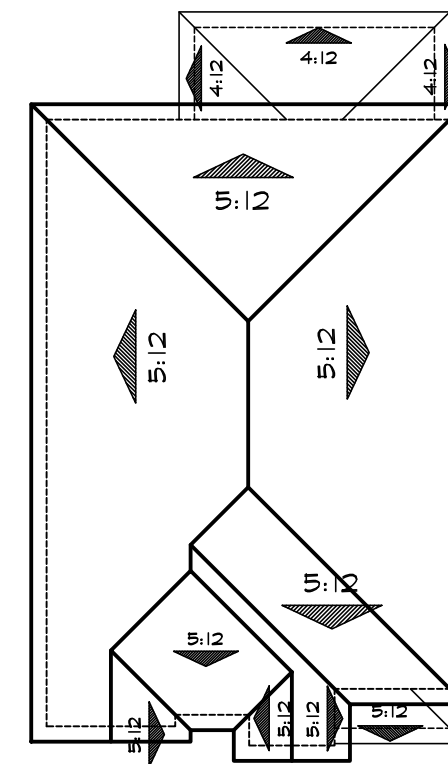

Roof Plan 'A'



--- DENOTES WINDOW GRIDS & TRIM AT SIDE ELEVATIONS FACING STREETS.

PLAN 11
Elevation A
STONEBROOK

BRENTWOOD, CA

West Coast
 HOME BUILDERS

LEGACY
 DESIGN GROUP

DATE JULY 01, 2024

11.5



Rear

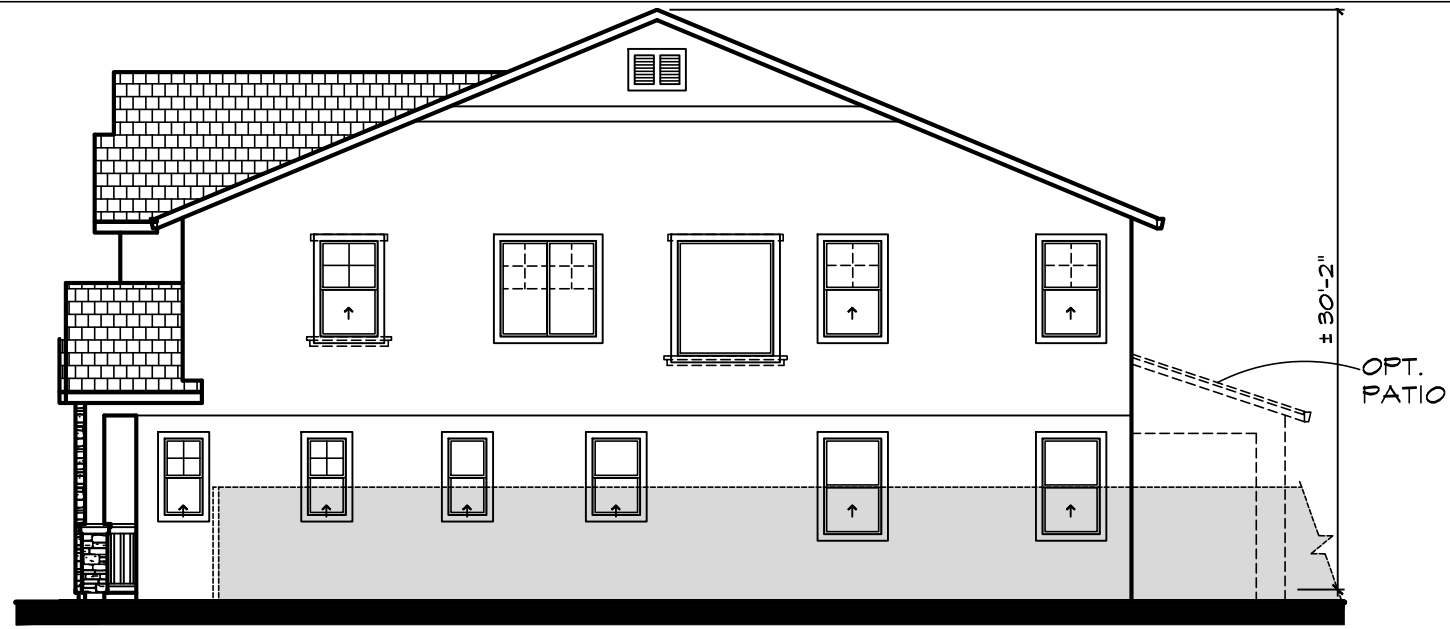

Right



Front - French Cottage

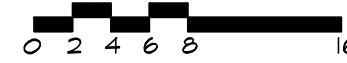

Left

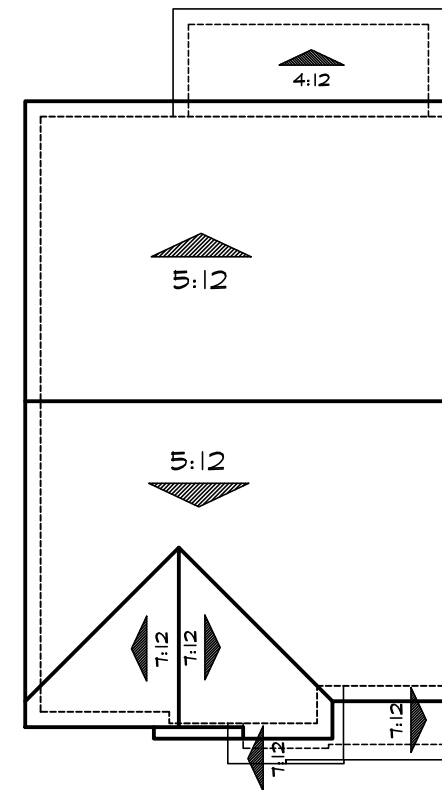

Roof Plan 'B'

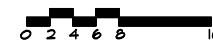

--- DENOTES WINDOW GRIDS & TRIM AT SIDE ELEVATIONS FACING STREETS.

PLAN 11
Elevation B
STONEBROOK

BRENTWOOD, CA

West Coast
HOME BUILDERS

LEGACY
DESIGN GROUP

DATE JULY 01, 2024

11.6

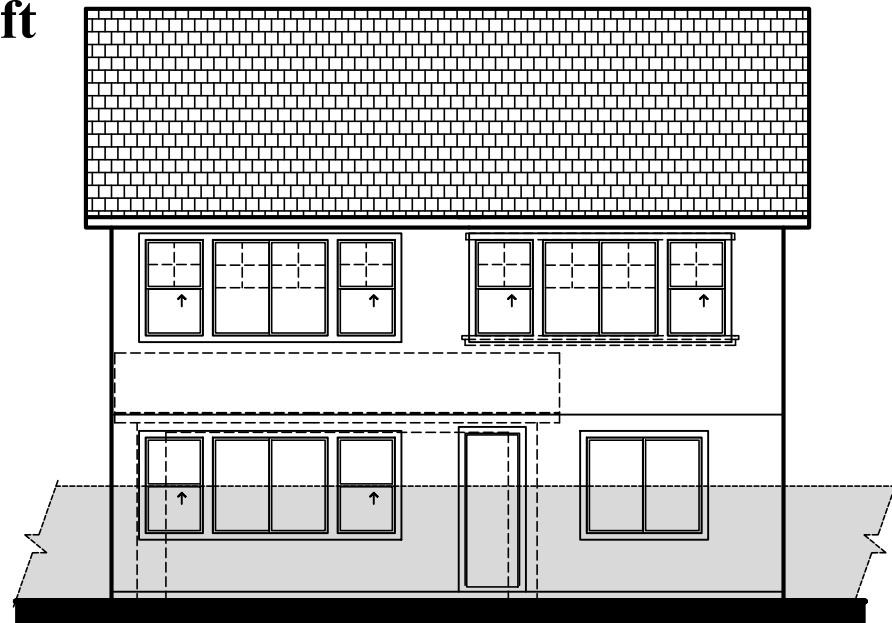

Rear

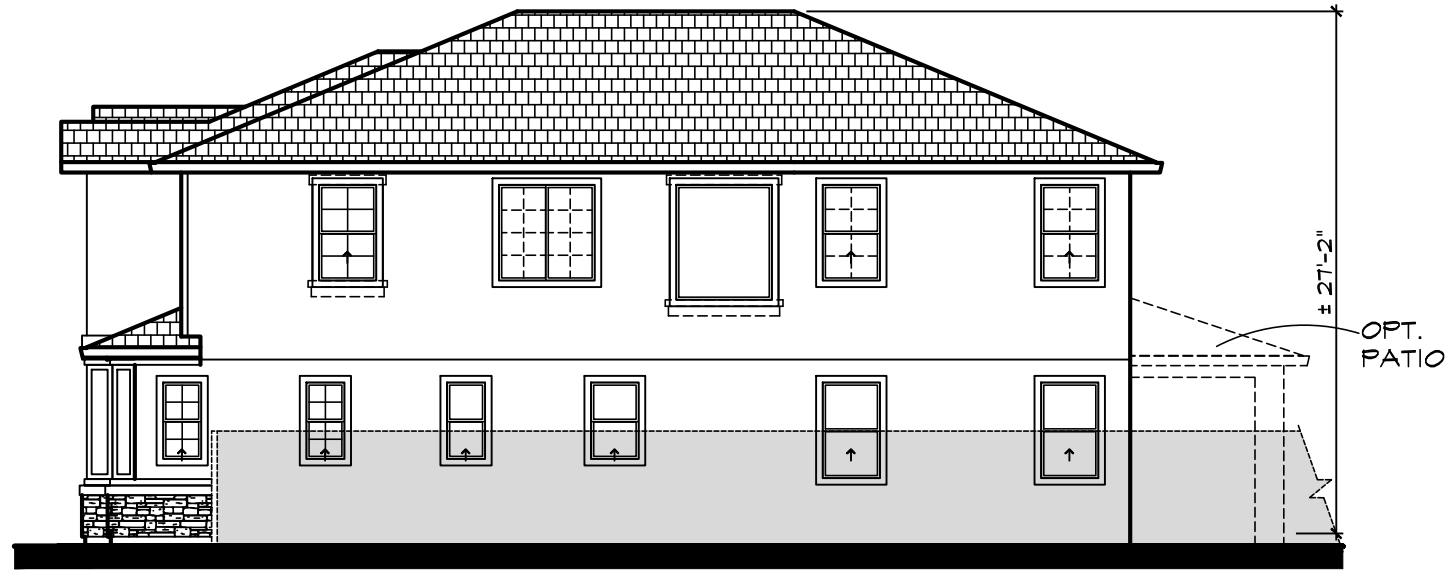

Right



Front - Craftsman

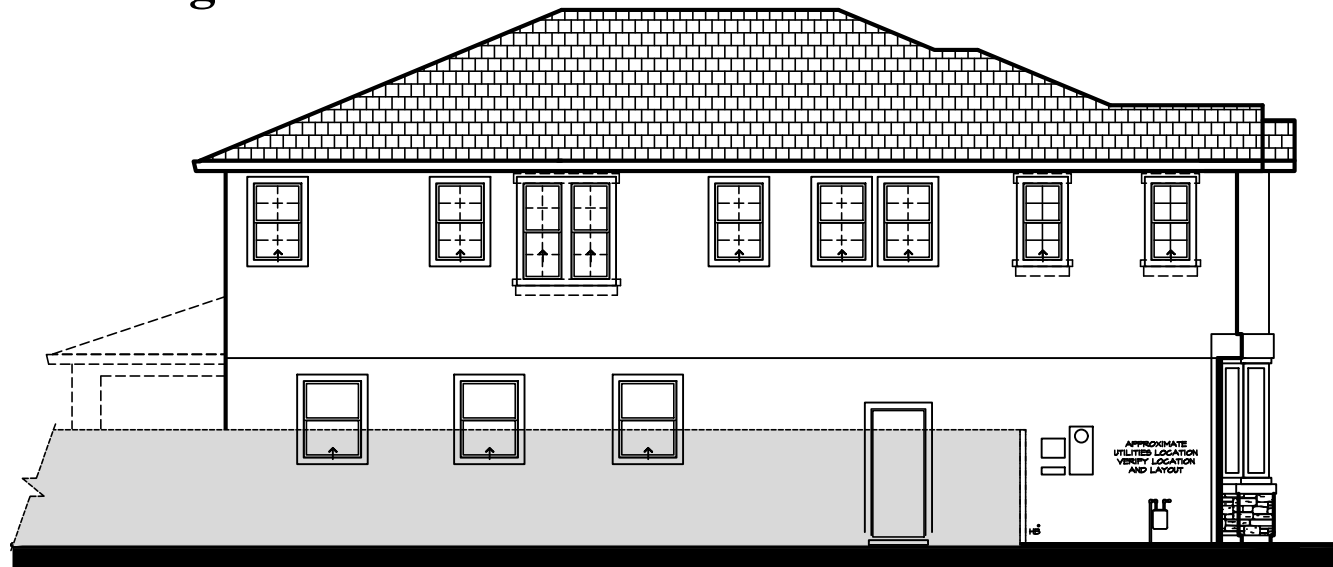
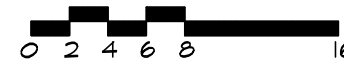

Left

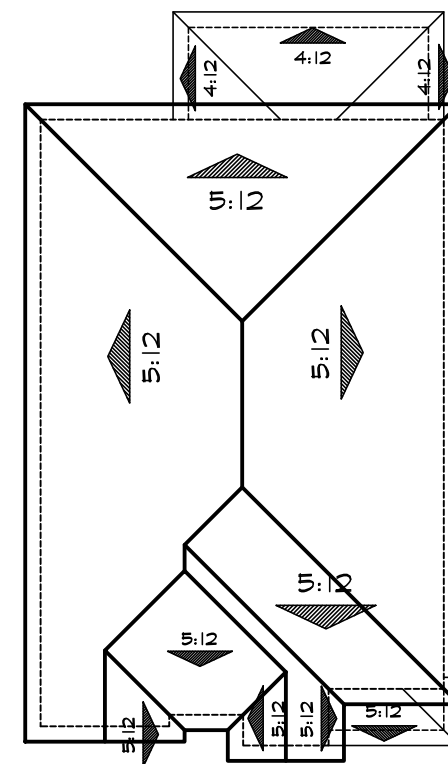

Roof Plan 'C'



--- DENOTES WINDOW GRIDS & TRIM AT SIDE ELEVATIONS FACING STREETS.

PLAN 11
Elevation C
STONEBROOK

BRENTWOOD, CA

West Coast
HOME BUILDERS

LEGACY
DESIGN GROUP

DATE JULY 01, 2024

11.7



Rear

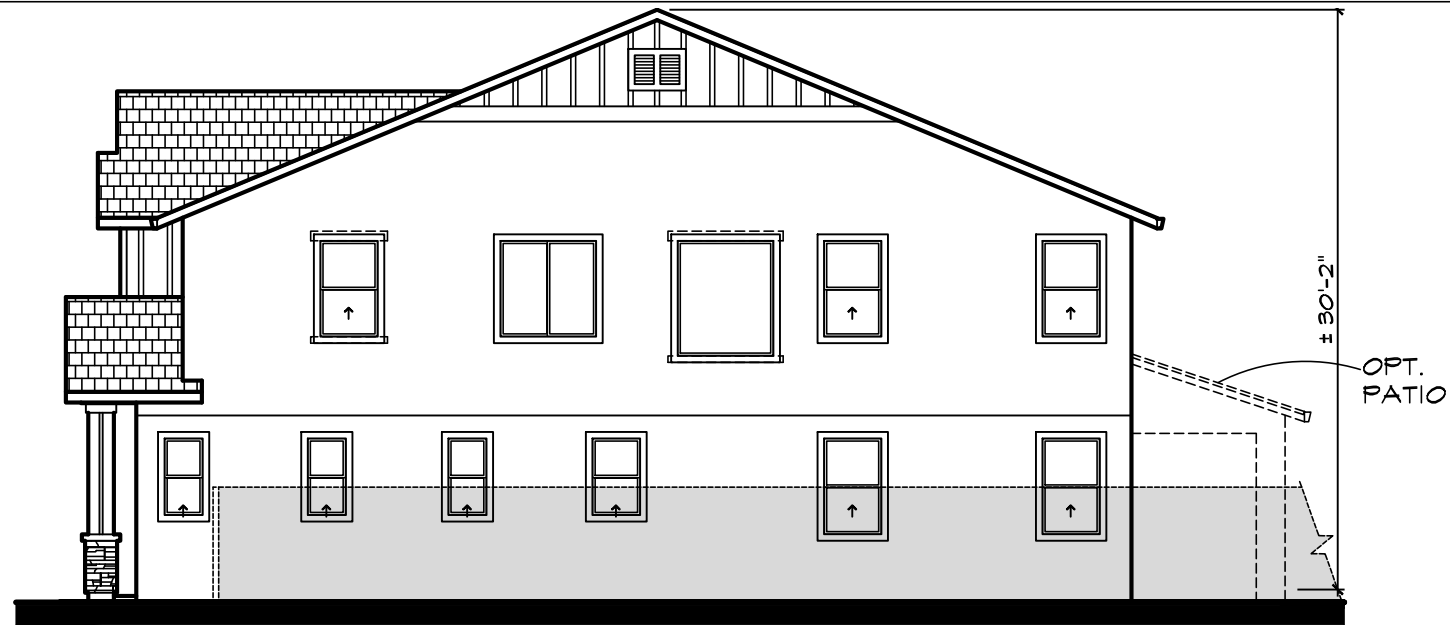

Right



Front - Bay Area Modern

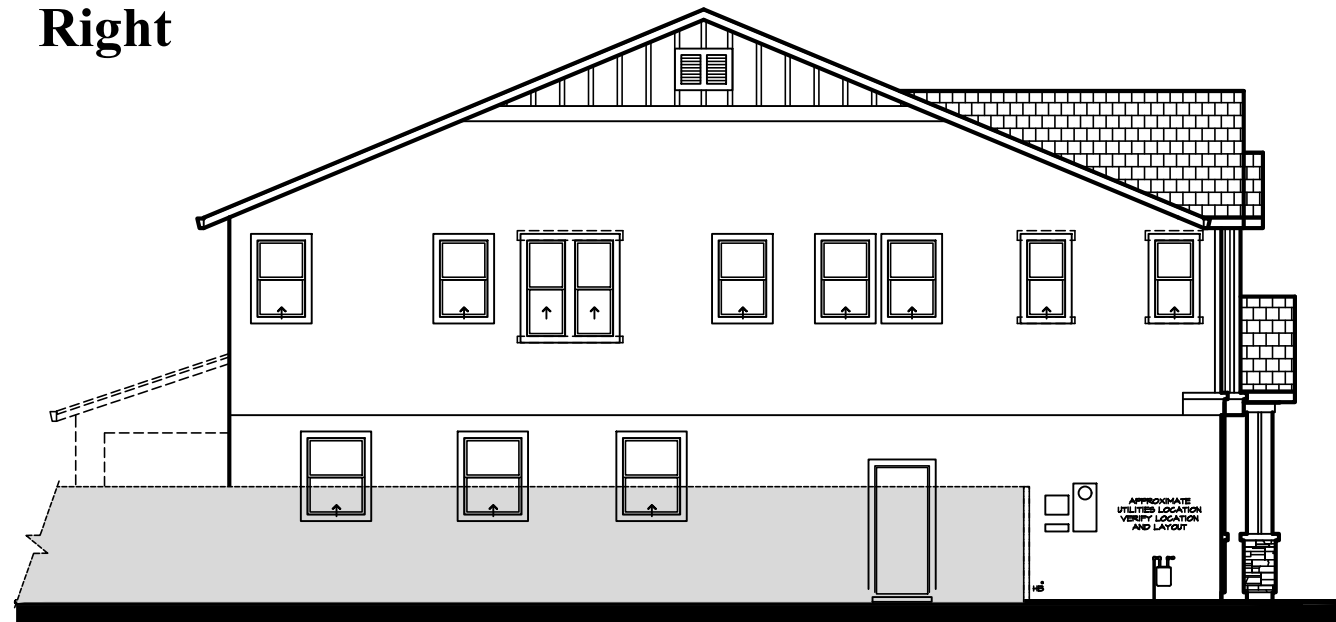
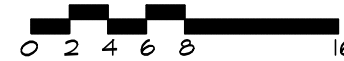

Left

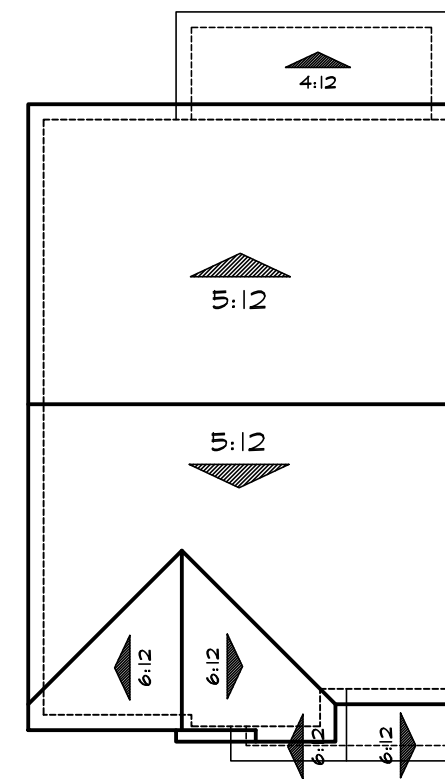

Roof Plan 'D'

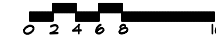

--- DENOTES WINDOW GRIDS & TRIM AT SIDE ELEVATIONS FACING STREETS.

PLAN 11
Elevation D
STONEBROOK

BRENTWOOD, CA

West Coast
 HOME BUILDERS

LEGACY
 DESIGN GROUP

DATE JULY 01, 2024

11.8

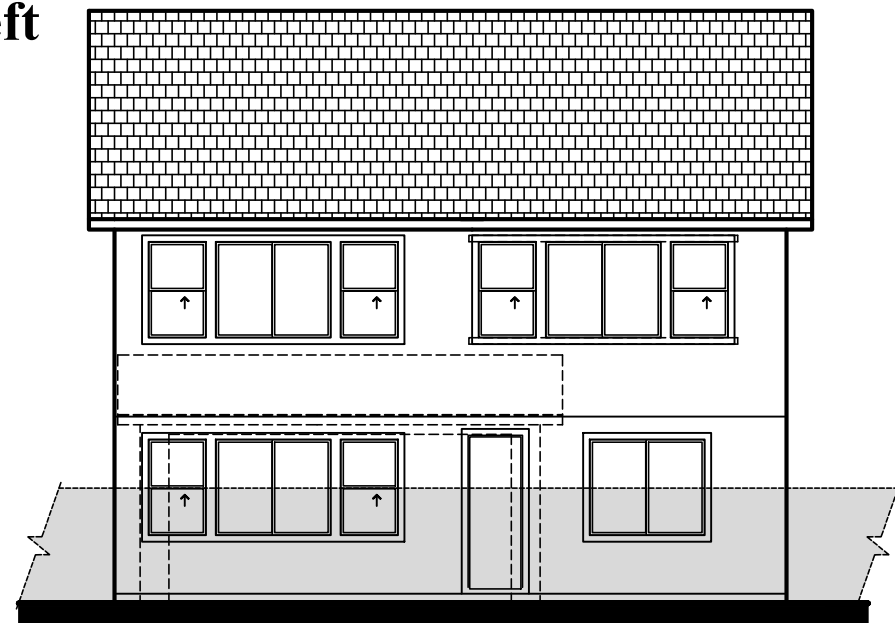

Rear



Elevation A - Tuscan



Elevation B - French Cottage



Elevation C - Craftsman



Elevation D - Bay Area Modern

MATERIAL LEGEND

- | | |
|--|---|
| <p>A VILLA CONCRETE TILE ROOFING
HIP & GABLE ROOFS
STUCCO BODY
STUCCO/FOAM TRIM
SIMULATED BRICK VENEER
STUCCO/FOAM CORBELS
DECORATIVE FOAM
DECORATIVE WROUGHT IRON
ROLL-UP GARAGE DOORS
W/ OPT. WINDOW LITES</p> | <p>B FLAT CONCRETE TILE ROOFING
HIP & GABLE ROOFS
STUCCO BODY
STUCCO/FOAM TRIM
MOCK VENTS
DECORATIVE FOAM
SIMULATED STONE VENEER
WOOD RAILING
ROLL-UP GARAGE DOORS
W/ OPT. WINDOW LITES</p> |
| <p>C FLAT CONCRETE TILE ROOFING
HIP & GABLE ROOFS
STUCCO BODY
STUCCO/FOAM TRIM
LAP SIDING
DECORATIVE FOAM
SIMULATED STONE VENEER
STUCCO/FOAM CORBELS
WOOD RAILING
WOOD SHAKES
ROLL-UP GARAGE DOORS
W/ OPT. WINDOW LITES</p> | <p>D FLAT CONCRETE TILE ROOFING
GABLE ROOFS
STUCCO BODY
STUCCO/FOAM TRIM
BOARD & BATTEN
MOCK VENTS
SIMULATED STONE VENEER
DECORATIVE FOAM
WOOD KICKERS
ROLL-UP GARAGE DOORS
W/ OPT. WINDOW LITES</p> |

PLAN 12
Front Elevations
STONEBROOK

BRENTWOOD, CA

West Coast
HOME BUILDERS

LEGACY
DESIGN GROUP

DATE

JULY 01, 2024

12.1

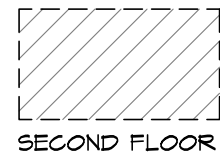
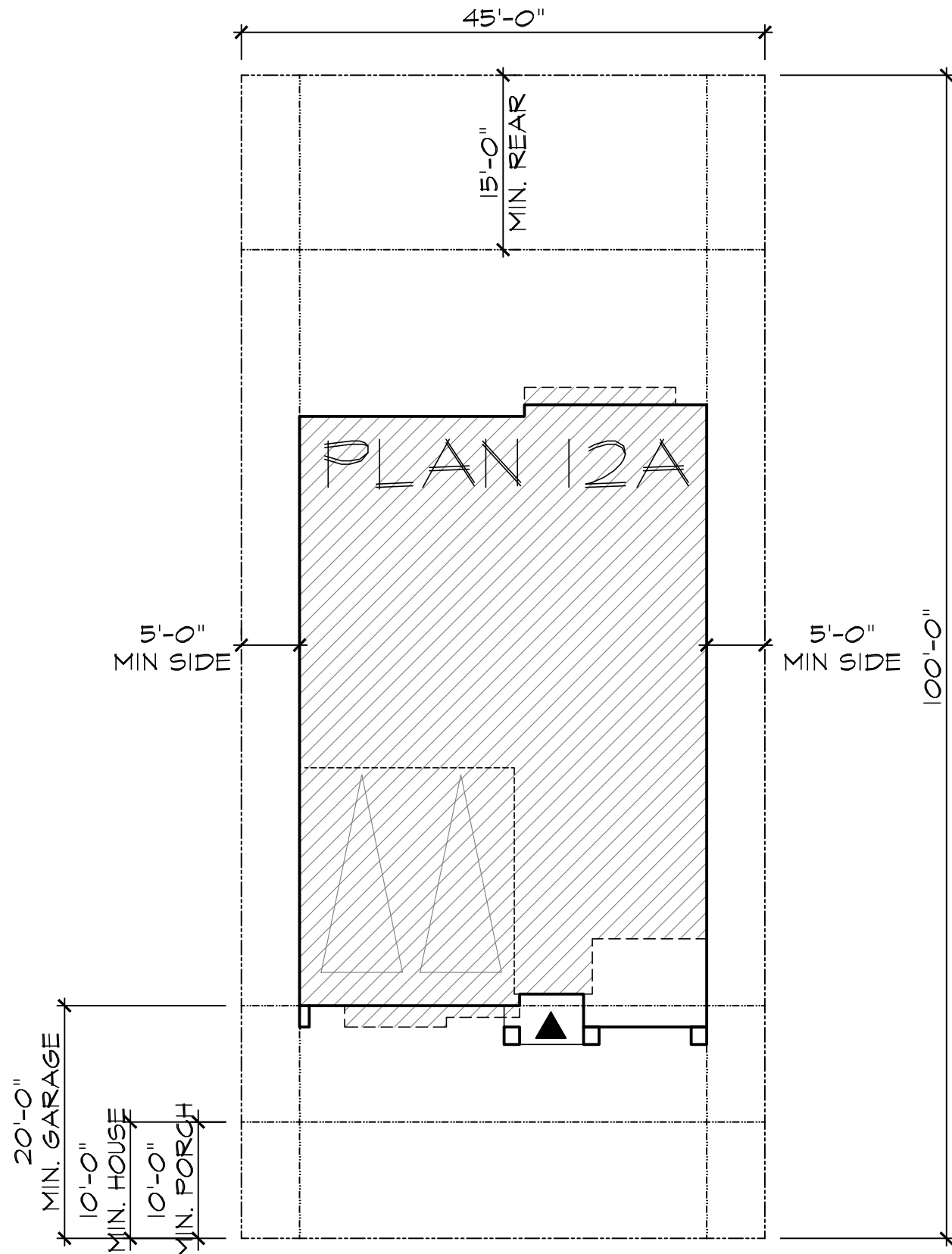

City of Brentwood
MINIMUM REQUIREMENTS

FRONT SETBACK - TO LIVING	10' MIN.
FRONT SETBACK - TO GARAGE	20' MIN.
SIDE YARD - SETBACK	5' MIN.
REAR YARD - SETBACK	15' MIN.
PORCH SETBACK	10' MIN.
LOT SIZE -	4,500 SQ. FT.
MAX COVERAGE - 2-STORY	40%

LOT COVERAGE 2-STORY: 40% max		
TYPICAL LOT SIZES	FOOTPRINT	APPROX. COVERAGE
45' x 100' = 4,500 SQ. FT.	1,833 SQ. FT.	40%

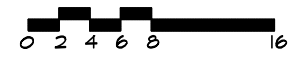

PLAN 12
Site Plan
STONEBROOK

BRENTWOOD, CA

West Coast
HOME BUILDERS

LEGACY
DESIGN **G**ROUP

DATE JULY 01, 2024

12.2

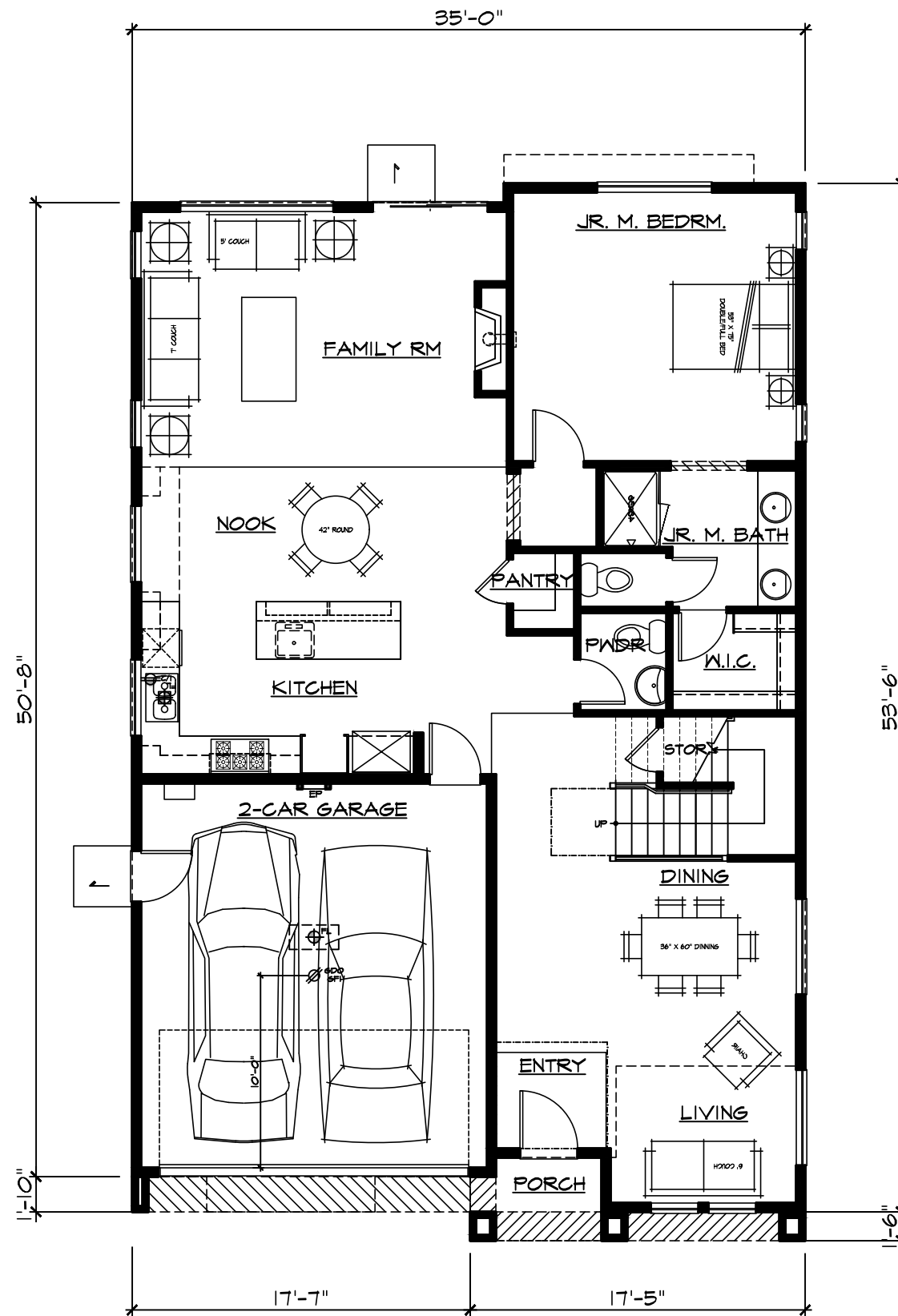

SQUARE FOOTAGE	
FIRST FLOOR	1425 SF
SECOND FLOOR	1675 SF
TOTAL LIVING AREA	3100 SF
<hr/>	
GARAGE	378 SF
PORCH	30 SF
FOOTPRINT	1833 SF

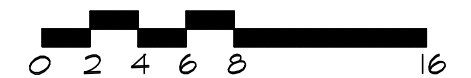

PLAN 12

First Floor

STONEBROOK

BRENTWOOD, CA

West Coast
HOME BUILDERS

LEGACY
DESIGN GROUP

DATE JULY 01, 2024

12.3

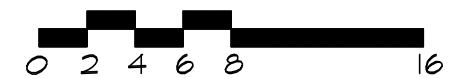
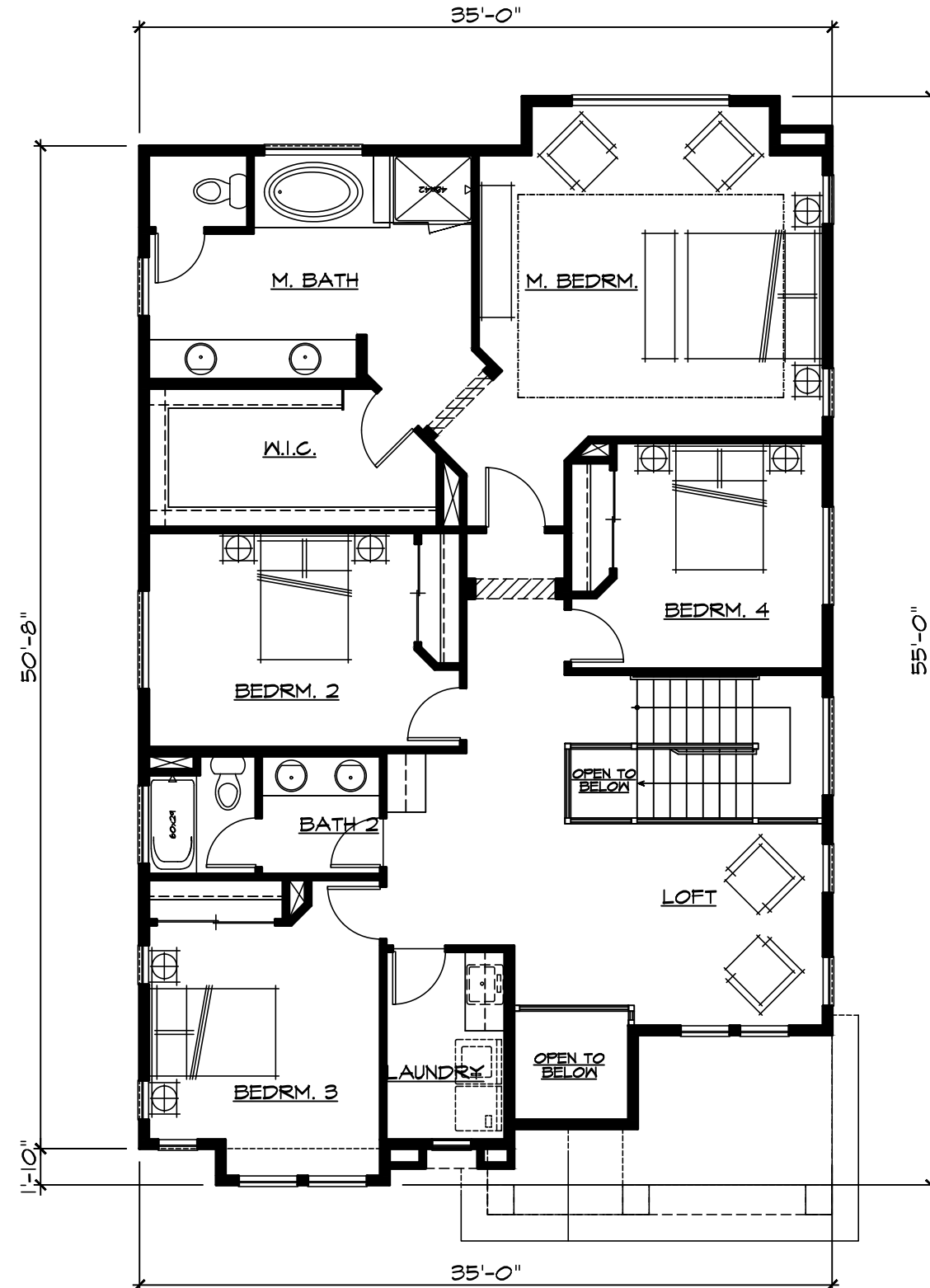

PLAN 12
Second Floor
STONEBROOK

BRENTWOOD, CA

West Coast
 HOME BUILDERS

LEGACY
DESIGN GROUP

DATE JULY 01, 2024

12.4



Right

± 27'-8"



Left

APPROXIMATE
UTILITIES LOCATION
VERIFY LOCATION
AND LAYOUT



Rear



Front - Tuscan

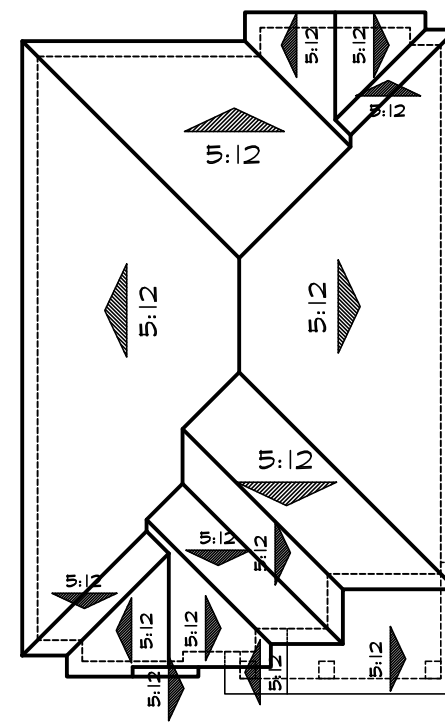
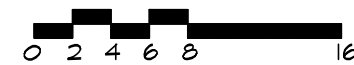

Roof Plan 'A'

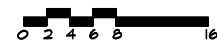

--- DENOTES WINDOW GRIDS & TRIM AT
SIDE ELEVATIONS FACING STREETS.

PLAN 12
Elevation A
STONEBROOK

BRENTWOOD, CA

West Coast
HOME BUILDERS

LEGACY
DESIGN GROUP

DATE JULY 01, 2024

12.5

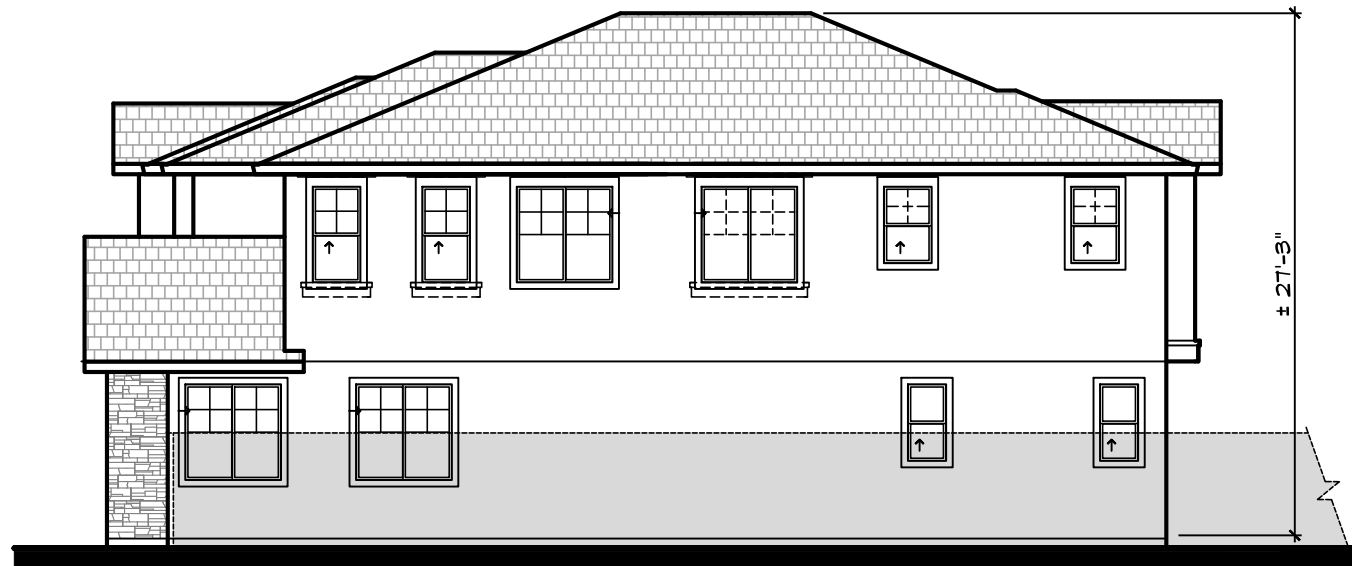

Right



Left



Rear



Front - French Cottage

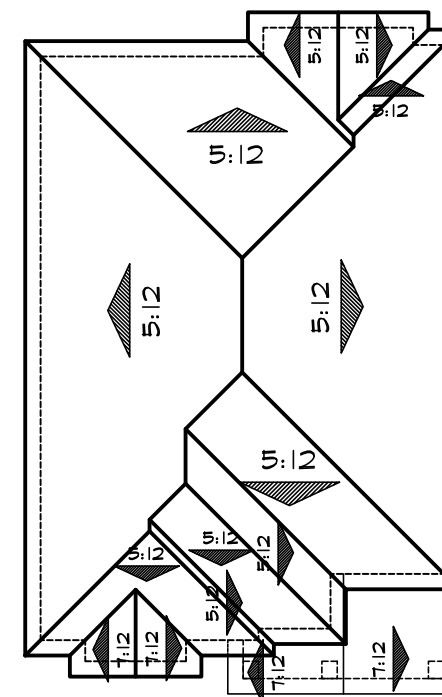
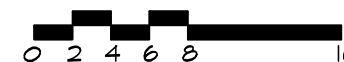

Roof Plan 'B'



--- DENOTES WINDOW GRIDS & TRIM AT SIDE ELEVATIONS FACING STREETS.

PLAN 12
Elevation B
STONEBROOK

BRENTWOOD, CA

West Coast
HOME BUILDERS

LEGACY
DESIGN GROUP

DATE JULY 01, 2024

12.6

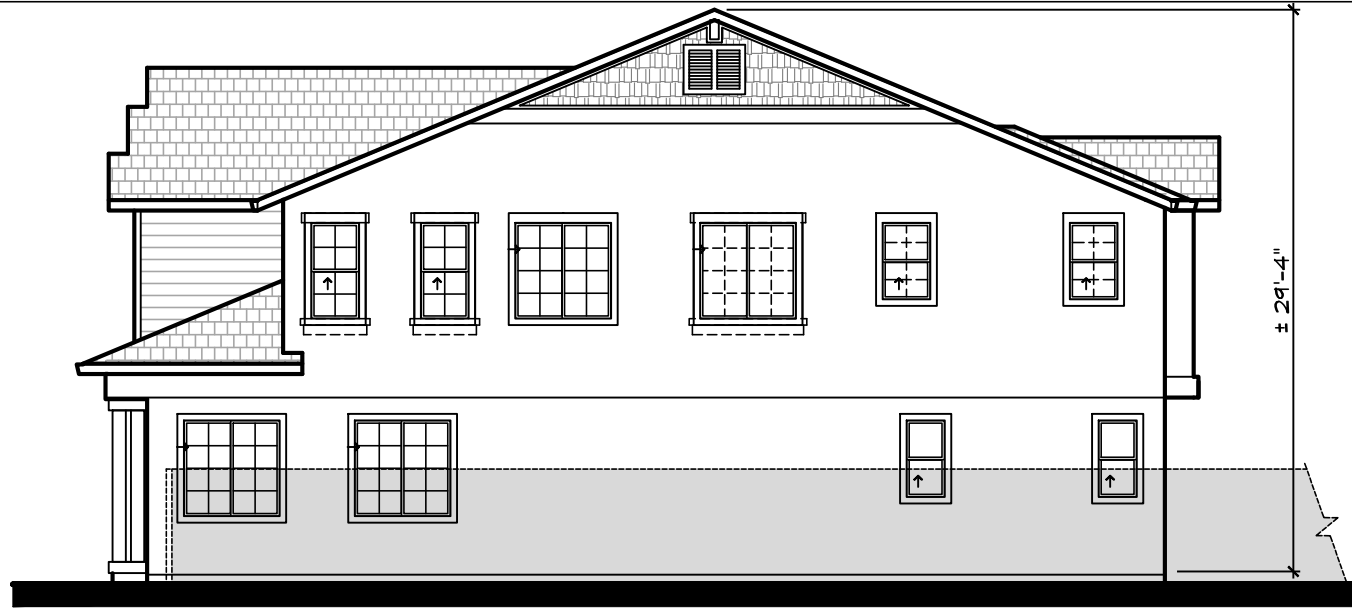

Right

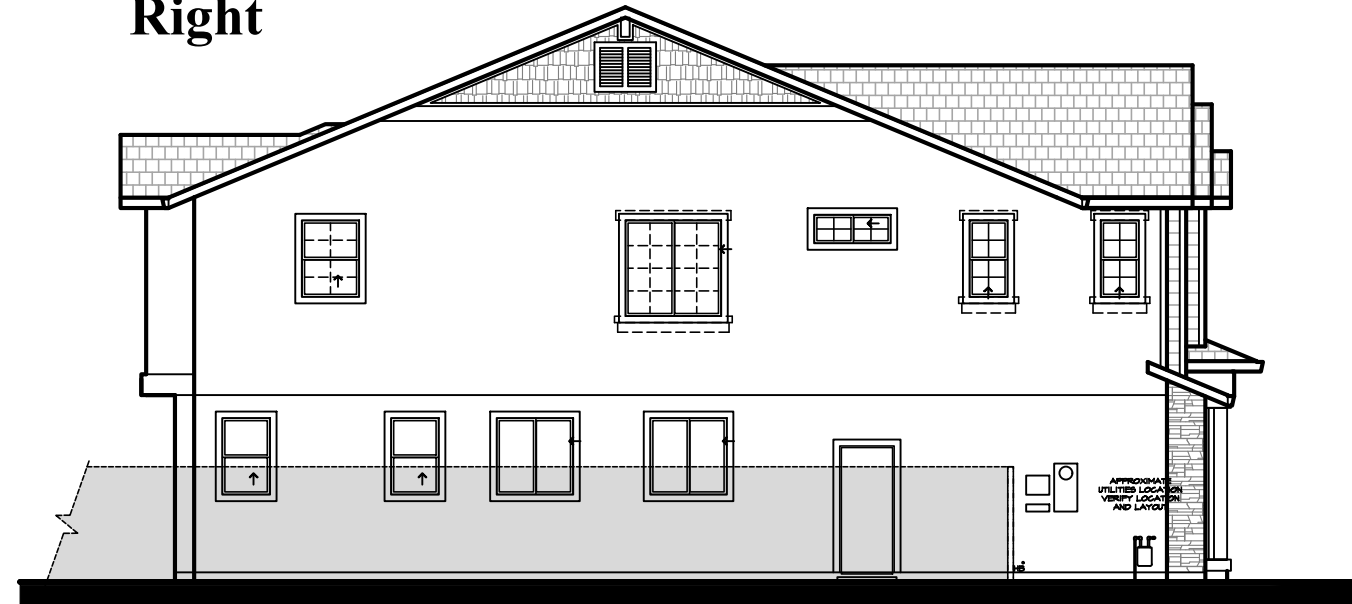

Left



Rear

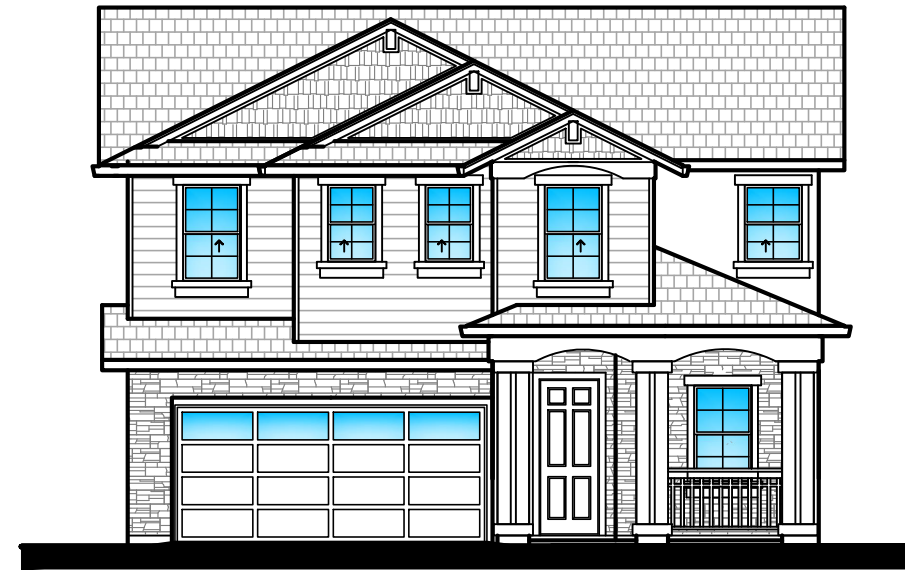

Front - Craftsman

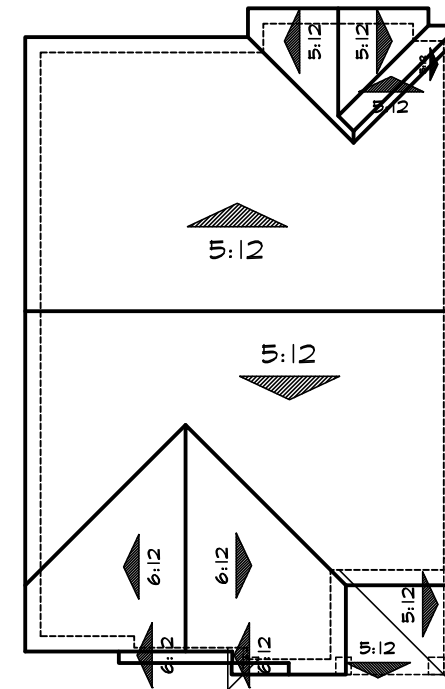
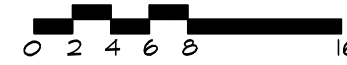

Roof Plan 'C'

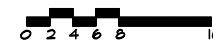

--- DENOTES WINDOW GRIDS & TRIM AT SIDE ELEVATIONS FACING STREETS.

PLAN 12
Elevation C
STONEBROOK
 BRENTWOOD, CA

West Coast
 HOME BUILDERS

LEGACY
DESIGN GROUP

DATE JULY 01, 2024

12.7



Right



Left



Rear

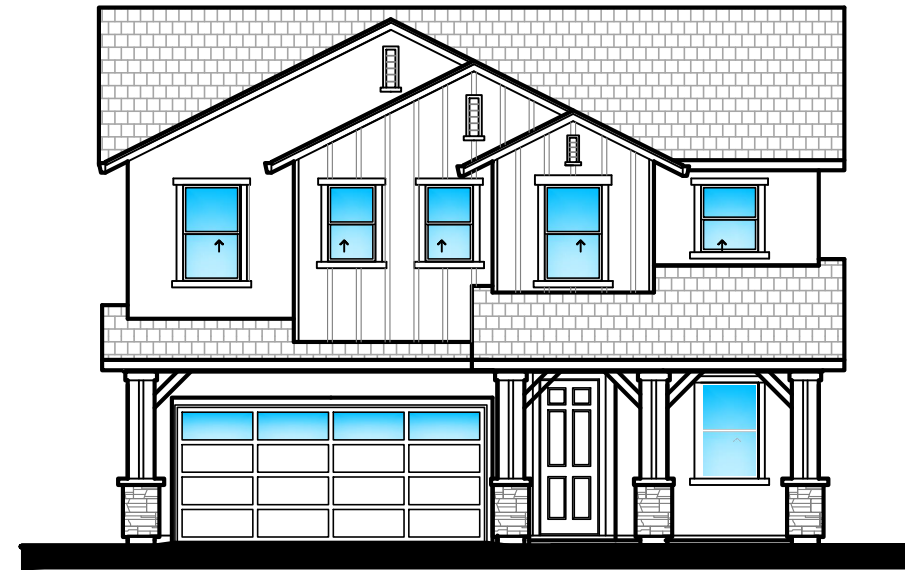

Front - Bay Area Modern

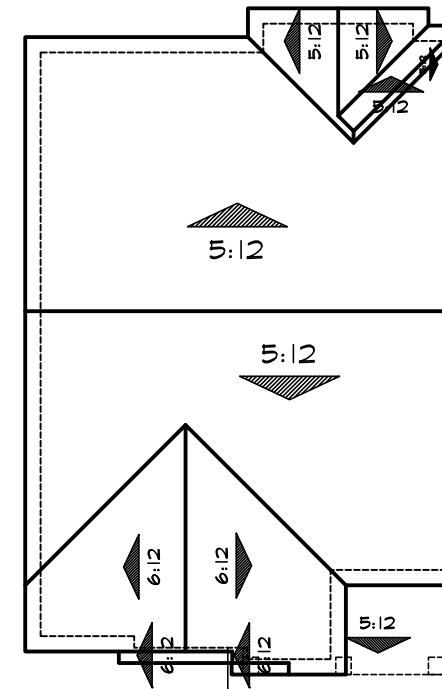
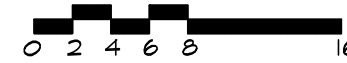

Roof Plan 'D'

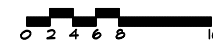

--- DENOTES WINDOW GRIDS & TRIM AT SIDE ELEVATIONS FACING STREETS.

PLAN 12
Elevation D
STONEBROOK

BRENTWOOD, CA

West Coast
 HOME BUILDERS

LEGACY
 DESIGN GROUP

DATE JULY 01, 2024

12.8



Elevation A - Tuscan

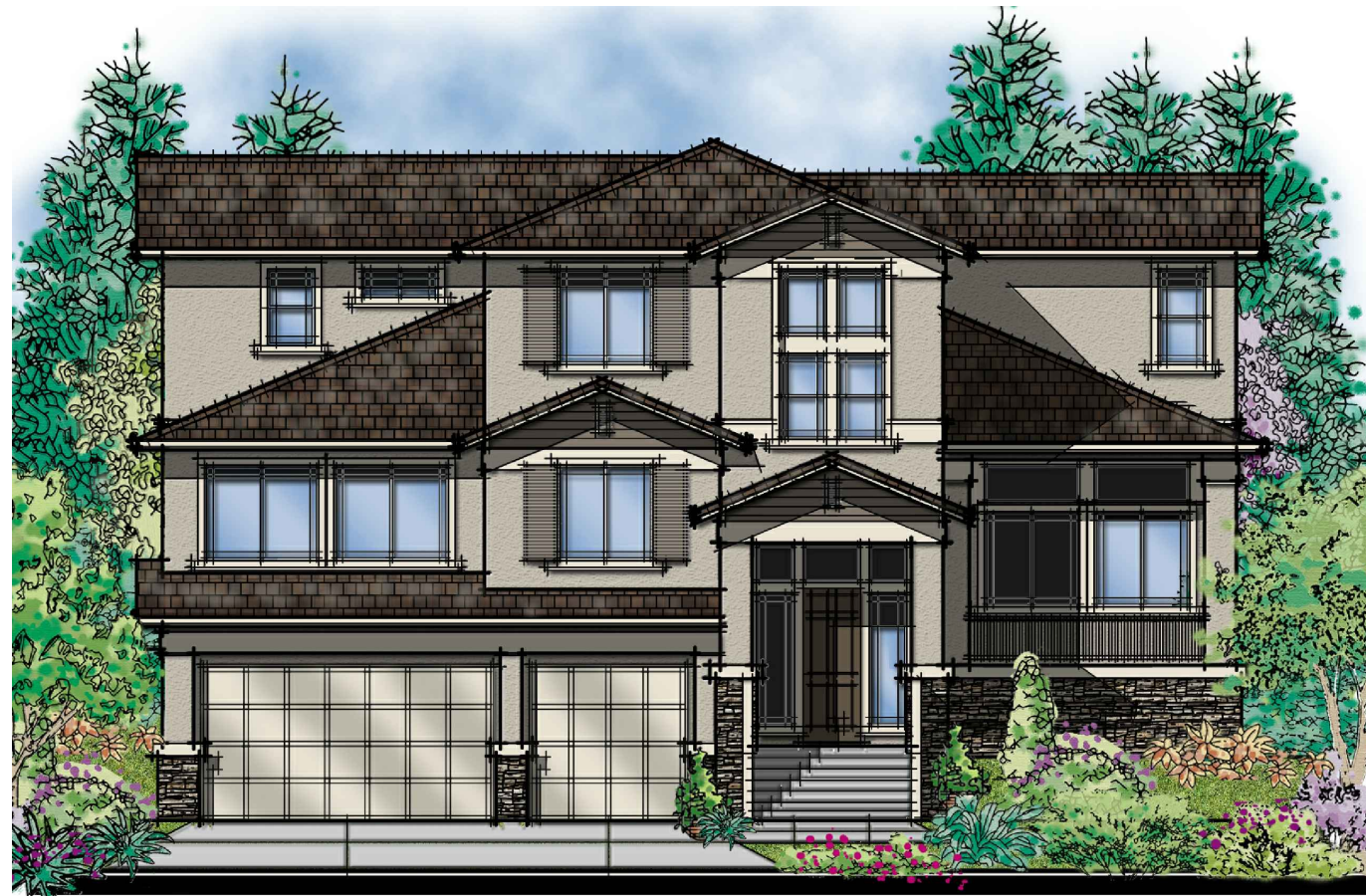

Elevation B - Craftsman

MATERIAL LEGEND

A VILLA CONCRETE TILE ROOFING
 GABLE ROOFS
 STUCCO BODY
 STUCCO/FOAM TRIM
 SIMULATED STONE VENEER
 SIMULATED STONE VENEER
 WOOD RAILING
 ROLL-UP GARAGE DOORS
 W/ OPT. WINDOW LITES

B FLAT CONCRETE TILE ROOFING
 HIP & GABLE ROOFS
 STUCCO BODY
 STUCCO/FOAM TRIM
 LAP SIDING
 DECORATIVE FOAM
 SIMULATED STONE VENEER
 WOOD RAILING
 MOCK VENTS
 ROLL-UP GARAGE DOORS
 W/ OPT. WINDOW LITES

PLAN 13
Front Elevations
STONEBROOK

BRENTWOOD, CA

West Coast
 HOME BUILDERS

LEGACY
DESIGN GROUP

DATE JULY 01, 2024

13.1

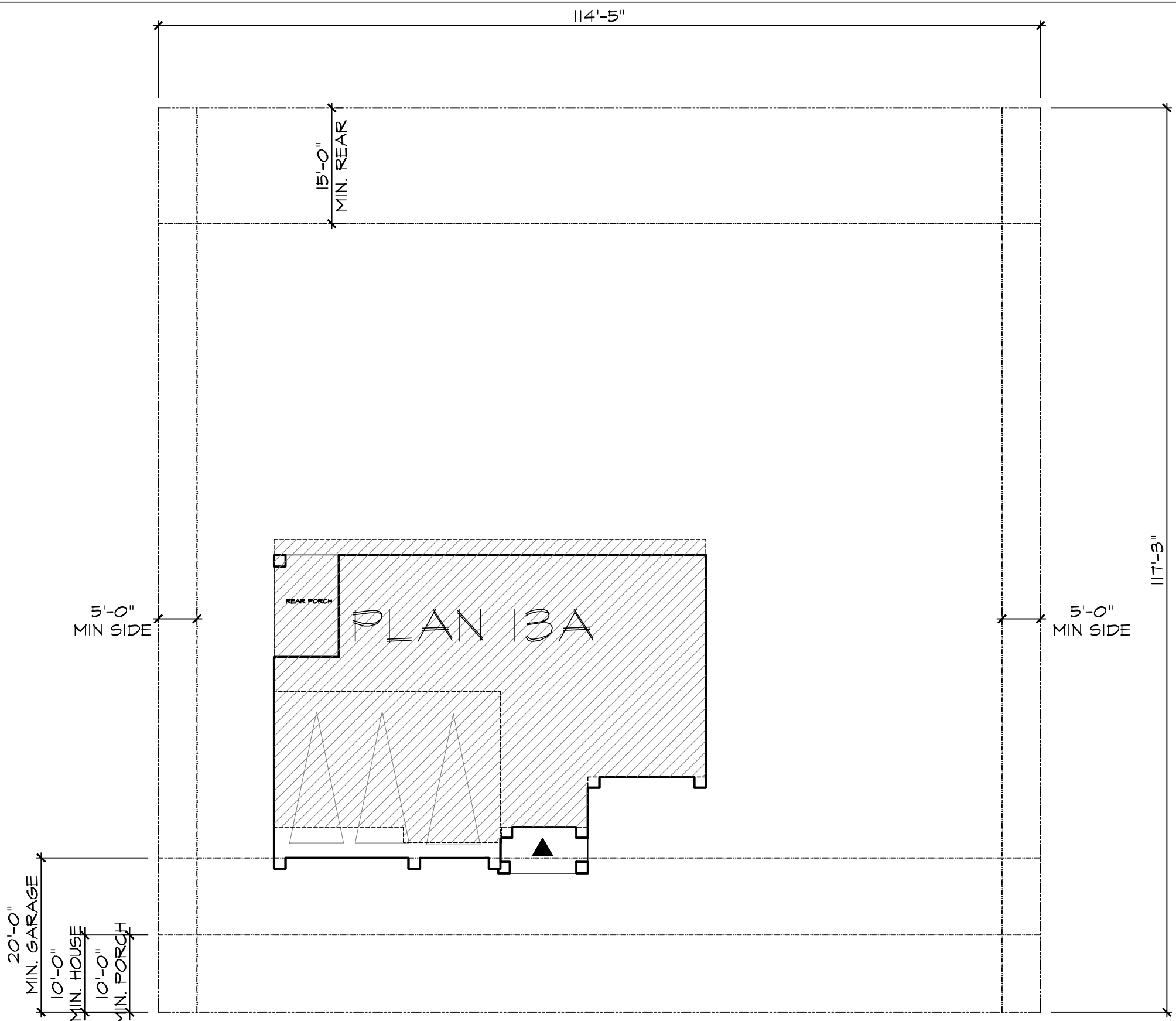

City of Brentwood
MINIMUM REQUIREMENTS

FRONT SETBACK - TO LIVING	10' MIN.
FRONT SETBACK - TO GARAGE	20' MIN.
SIDE YARD - SETBACK	5' MIN.
REAR YARD - SETBACK	15' MIN.
PORCH SETBACK	10' MIN.
LOT SIZE	13,414 SQ. FT.
MAX COVERAGE - 2-STORY	40%

LOT COVERAGE 2-STORY: 40% max		
TYPICAL LOT SIZES	FOOTPRINT	APPROX. COVERAGE
114'-5" x 117'-3" = 13,414 SQ. FT.	2,073 SQ. FT.	15%

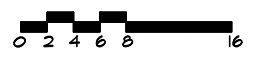

PLAN 13
Site Plan
STONEBROOK

BRENTWOOD, CA

West Coast
HOME BUILDERS

LEGACY
DESIGN GROUP

DATE JULY 01, 2024

13.2



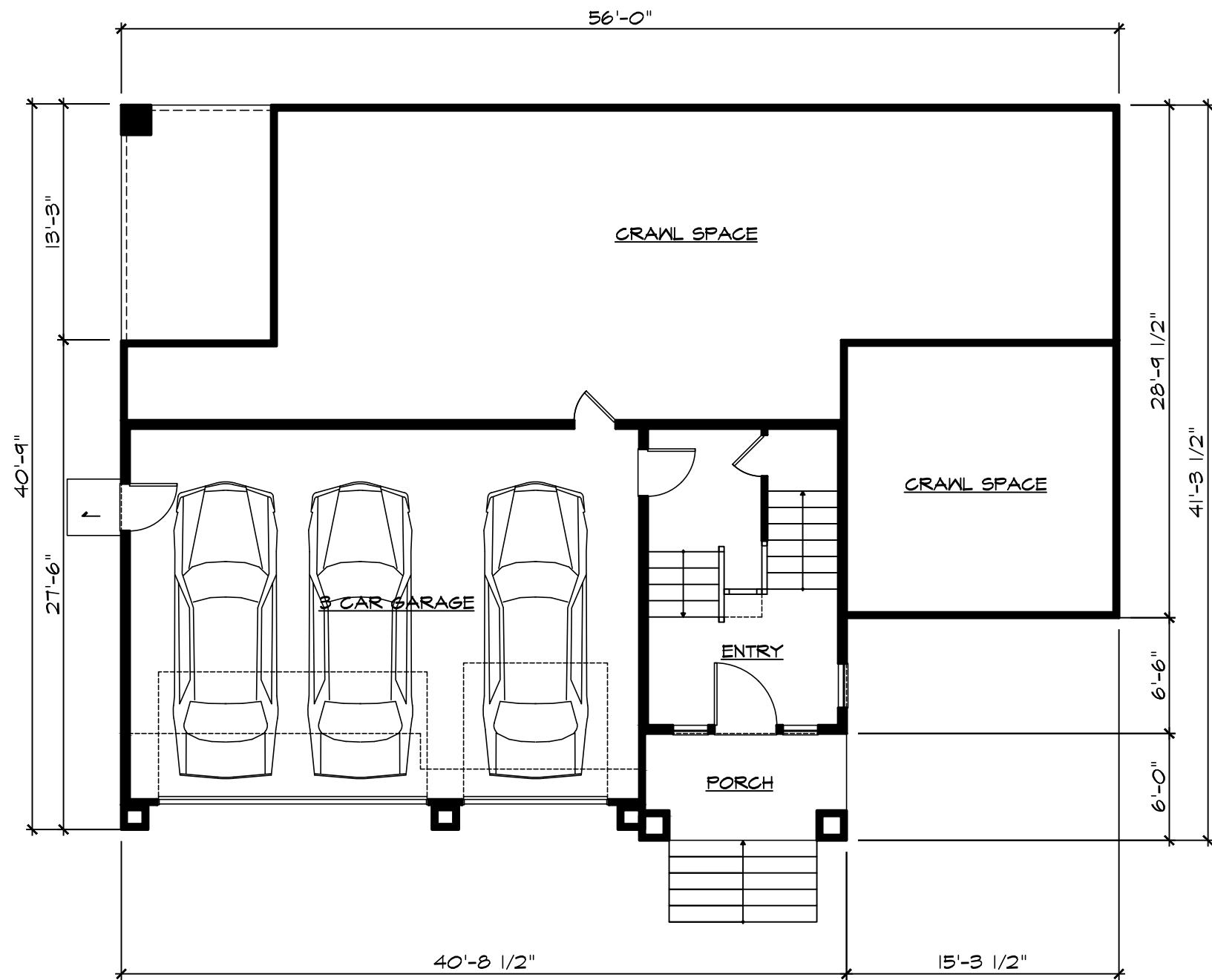

SQUARE FOOTAGE	
ENTRY LEVEL	204 SF
MAIN LEVEL	1657 SF
UPPER LEVEL	1361 SF
TOTAL LIVING AREA	3222 SF
<hr/>	
GARAGE	623 SF
PORCH	64 SF
PORCH	111 SF
FOOTPRINT	2073 SF



PLAN 13

Entry Level

STONEBROOK

BRENTWOOD, CA

West Coast
HOME BUILDERS

LEGACY
DESIGN GROUP

DATE JULY 01, 2024

13.3

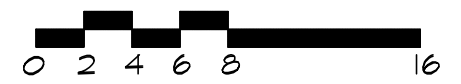
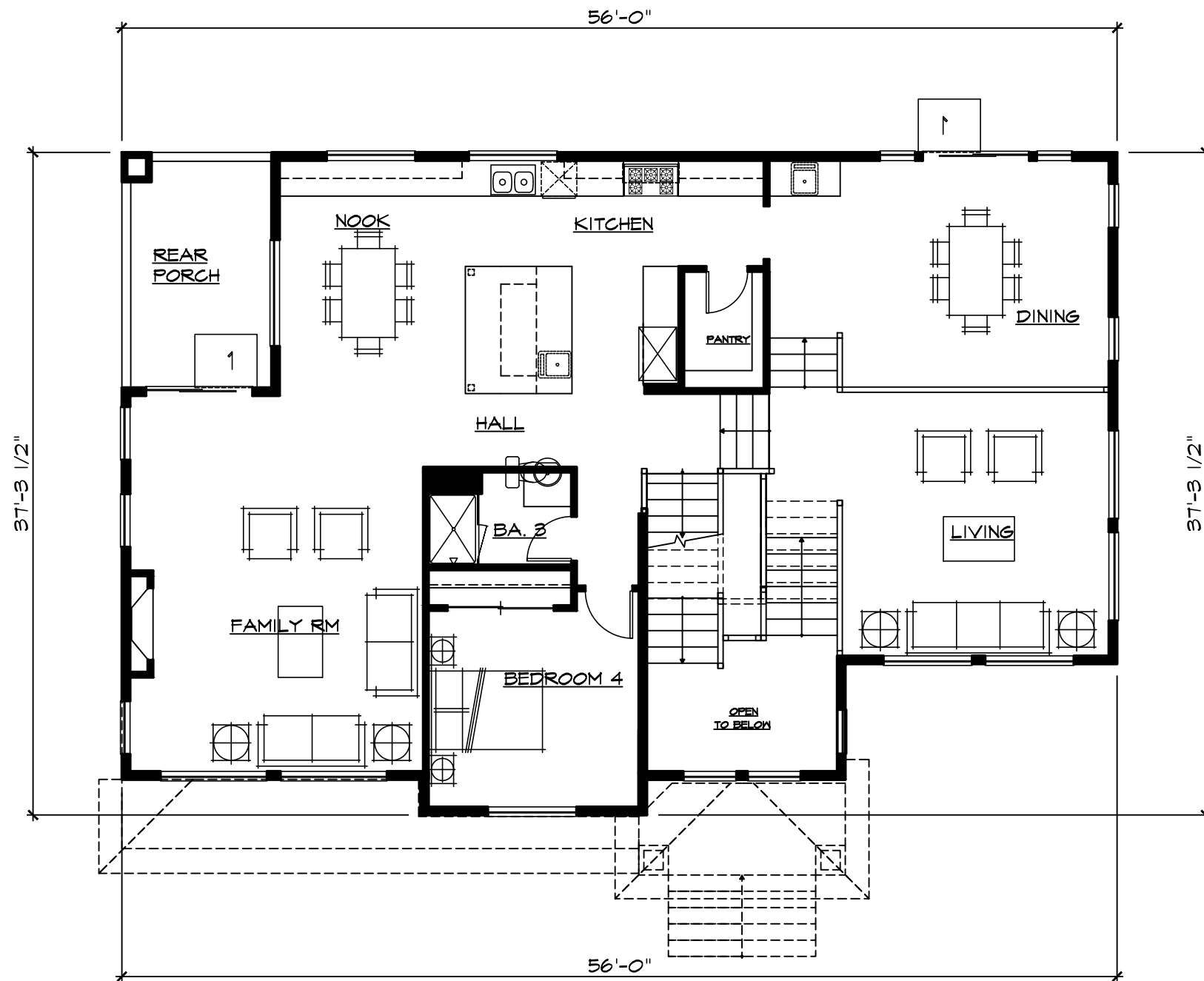

PLAN 13

Main Level

STONEBROOK

BRENTWOOD, CA

West Coast
HOME BUILDERS

LEGACY
DESIGN GROUP

DATE JULY 01, 2024

13.4

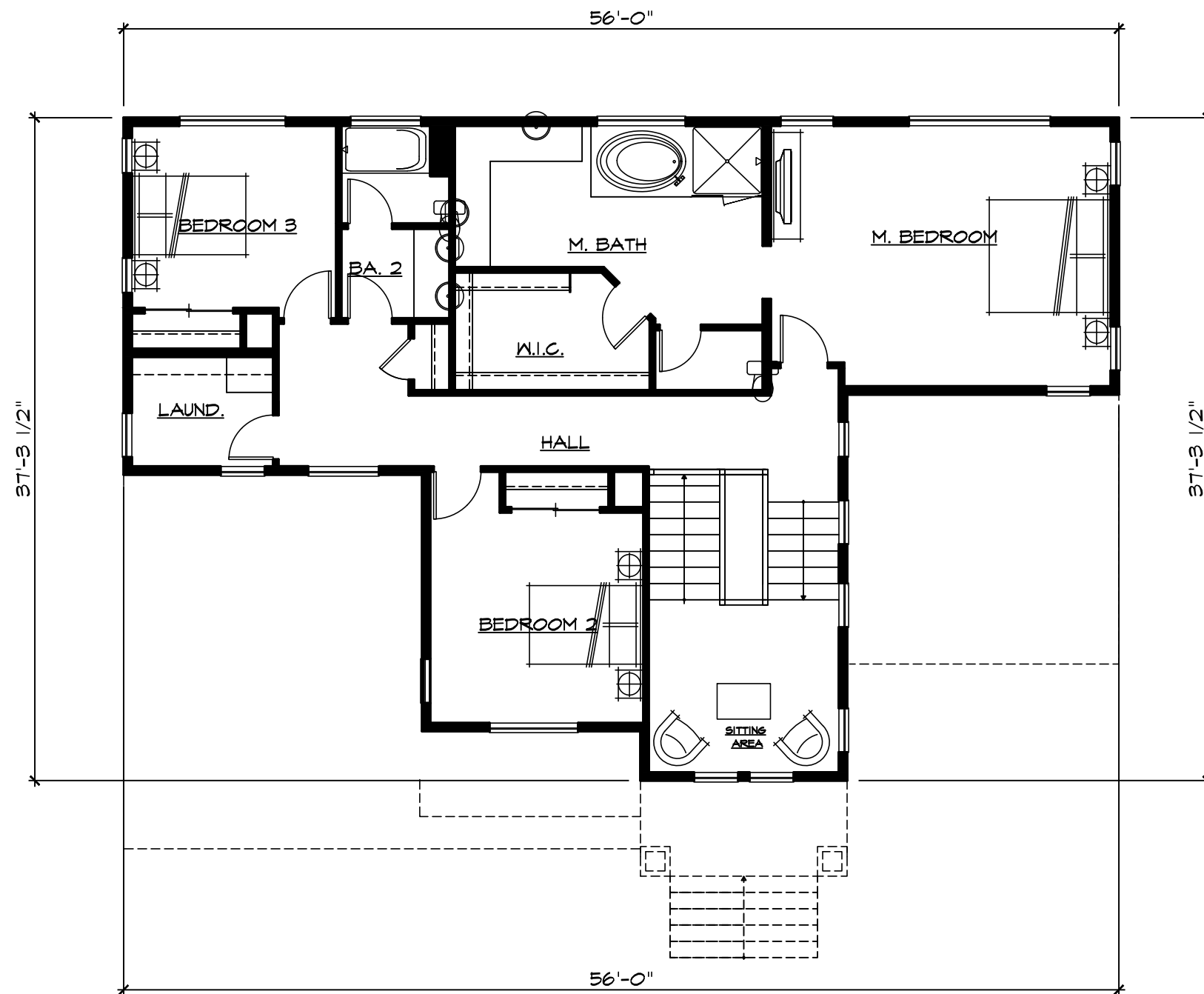

PLAN 13

Upper Level

STONEBROOK

BRENTWOOD, CA

West Coast
HOME BUILDERS

LEGACY
DESIGN GROUP

DATE JULY 01, 2024

13.5



Right



Left



Rear



Front - Tuscan

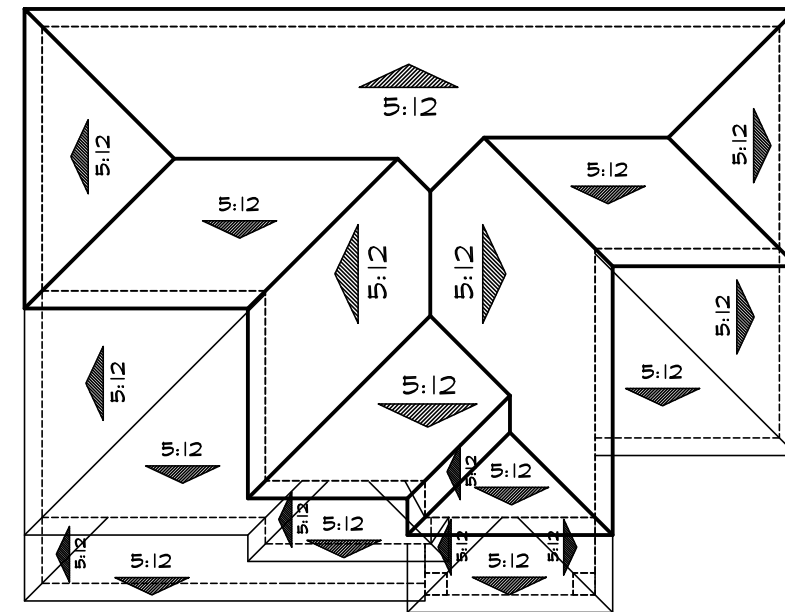
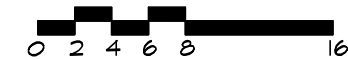

Roof Plan 'A'

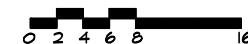

DENOTES WINDOW GRIDS AT SIDE ELEVATIONS FACING STREETS.

PLAN 13

Elevation A

STONEBROOK

BRENTWOOD, CA

West Coast HOME BUILDERS

LEGACY DESIGN GROUP

DATE JULY 01, 2024

13.6



Right



Left



Rear



Front - Craftsman

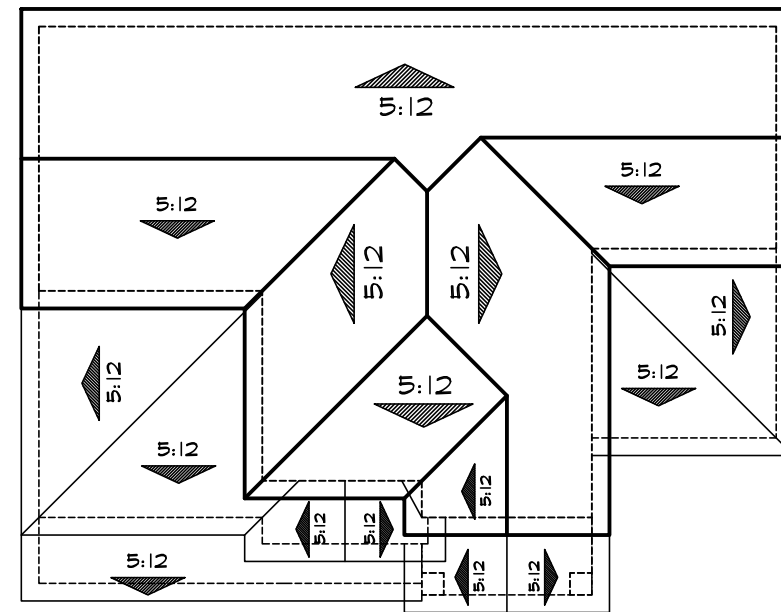
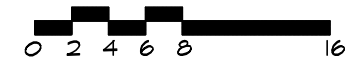

Roof Plan 'B'

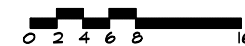

DENOTES WINDOW GRIDS AT SIDE ELEVATIONS FACING STREETS.

PLAN 13

Elevation B

STONEBROOK

BRENTWOOD, CA

West Coast HOME BUILDERS

LEGACY DESIGN GROUP













DATE JULY 01, 2024

13.7

SUBDIVISION: STONEBROOK

BRENTWOOD, CA

COLOR BOARD

SCHEME	VILLA TILE	FLAT TILE	BODY 1	BODY 2	TRIM	ACCENT	STONE	BRICK
SCHEME 1	1VICS3233 Brown Blend 	1FACS1132 Charcoal Brown Blend 	KMW28-1 Clam 	KM5784-3 Creek Bay 	KM5792-3 Stacked Stone 	KM4582 Beaver Pelt 	BLACK MOUNTAIN PRO-FIT ALPINE LEDGESTONE 	Sandy Creek 
SCHEME 2	1VICS6464 CA Mission Blend 	1FACS6464 CA Mission Blend 	KMW10-1 Pogo Sands 	KM4937-3 Paw Print 	KM5777 Cannery Park 	KM4897-5 Yin Mist 	GRAND MESA COUNTRY LEDGESTONE 	Coastal Bluff 
SCHEME 3	1VICS7330 Verona Clay 	1FACS0024 - Desert Sage 	KM4634-2 Community 	KM4635-3 Tanglewood 	KM46 Acoustic White 	KMA56-5 Pinyon Pine 	HUDSON BAY COUNTRY LEDGESTONE 	Moroccan Sand 
SCHEME 4	1VICS6464 CA Mission Blend 	1FACS6464 CA Mission Blend 	KM232 Toscana 	KM412 Cargo 	KM4582 Beaver Pelt 	KMA68-5 Leather Satchel 	ECHO RIDGE PRO-FIT ALPINE LEDGESTONE 	High Desert 
SCHEME 5	1VICS7330 Verona Clay 	1FACS1430 Charcoal Blend 	KM4719 Harvest Dance 	KM4718-2 Wagon Wheel 	KM4575-5 Mud Room 	KMA76-5 Log Cabin 	ASPEN COUNTRY LEDGESTONE 	Marsh Pointe 
SCHEME 6	1VICS3233 Brown Blend 	1FBCF1132 Charcoal Brown Blend 	KM4942-2 Tin Man 	KM4937-3 Paw Print 	KM4939-5 Arrowhead 	KM417 Oxford Brown 	SUMMIT PEAK PRO-FIT ALPINE LEDGESTONE 	Tobacco Road 

ROOFING: Boral Concrete Tile or Equivalent
 STONE: Boral Cultured Stone/Cultured Brick or Equivalent
 PAINT: Kelly Moore or Equivalent

West Coast
HOME BUILDERS

LEGACY
DESIGN GROUP









































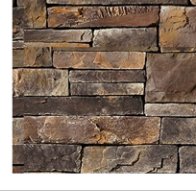



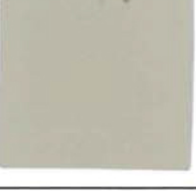

0.1

July 01, 2024

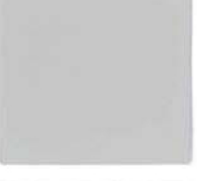
SUBDIVISION: STONEBROOK

BRENTWOOD, CA

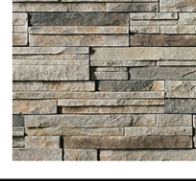
COLOR BOARD

SCHEME	VILLA TILE	FLAT TILE	BODY 1	BODY 2	TRIM	ACCENT	STONE	BRICK
SCHEME 7	1VICS3163 Camino Blend 	1FACS1132 Charcoal Brown Blend 	HL4201 Adobe White 	KM5705-3 Pioneer Village 	KM5800-5 Sausalito Ridge 	KMA82-5 Lamp Post 	GRAY SOUTHERN LEDGESTONE 	Coastal Bluff 
SCHEME 8	1VICS0024 Desert Sage 	1FACS1430 Charcoal Blend 	KM4899-1 Gray Spell 	KM4942-2 Tin Man 	KM4786-1 Fresh Linen 	KM407 Carbon 	BLACK MOUNTAIN PRO-FIT ALPINE LEDGESTONE 	Alamo 
SCHEME 9	1VICS3233 Brown Blend 	1FBCF1430 Charcoal Blend 	KM305 Ironwood 	KM4938-3 Grouchy Badger 	KM216 Malibu Beige 	KM5804-5 Yacht Club 	SUMMIT PEAK PRO-FIT ALPINE LEDGESTONE 	Capers Island 
SCHEME 10	1VICS3233 Brown Blend 	1FACS1132 Charcoal Brown Blend 	KM4566-3 City Loft 	KM4559-3 Mink 	KM5800-5 Sausalito Ridge 	KMA66-5 Santana Soul 	WOLF CREEK COUNTRY LEDGESTONE 	Rustic Manor 
SCHEME 11	1VICS7330 Verona Clay 	1FBCF1132 Charcoal Brown Blend 	KM49 Antique White 	KM5767-2 Greige 	KM14 Frost 	KM4818-5 Knit Cardigan 	HUDSON BAY COUNTRY LEDGESTONE 	Old Guignard 
SCHEME 12	1VICS0024 Desert Sage 	1FBCF1430 Charcoal Blend 	KM4908-1 Bashful Emu 	KM4896-3 Stone Hearth 	KM49 Antique White 	KMA82-5 Lamp Post 	ECHO RIDGE PRO-FIT ALPINE LEDGESTONE 	Mt Rushmore 

ROOFING: Boral Concrete Tile or Equivalent
 STONE: Boral Cultured Stone/Cultured Brick or Equivalent
 PAINT: Kelly Moore or Equivalent

West Coast
HOME BUILDERS
LEGACY
DESIGN GROUP











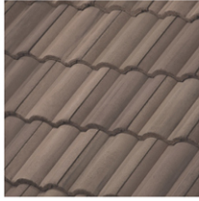

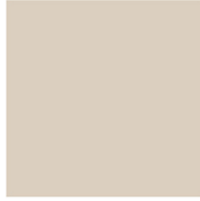







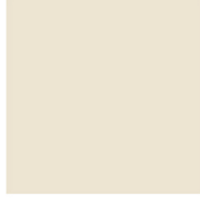





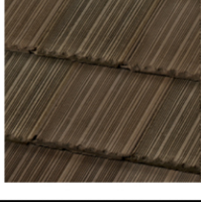

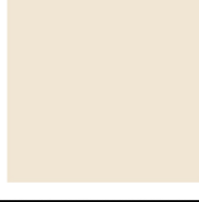

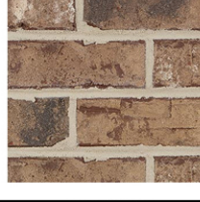
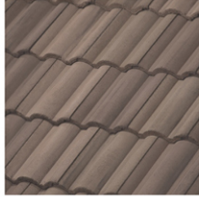
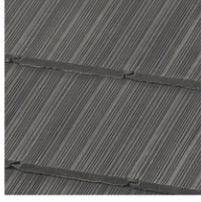



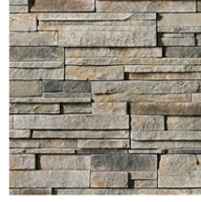

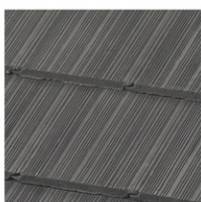



0.2

July 01, 2024

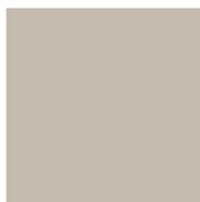
SUBDIVISION: STONEBROOK

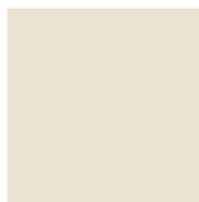
BRENTWOOD, CA

COLOR BOARD











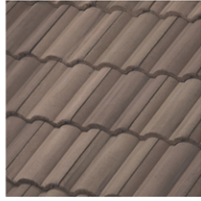







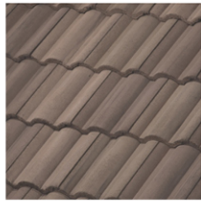
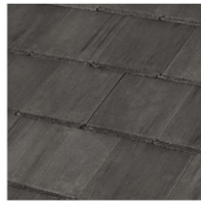

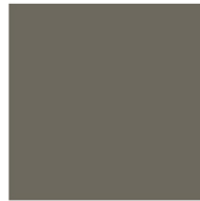
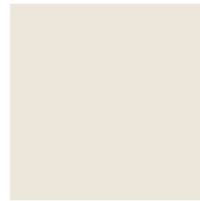



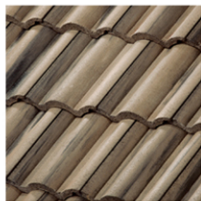
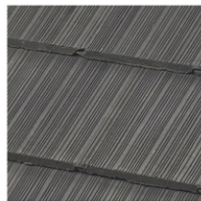

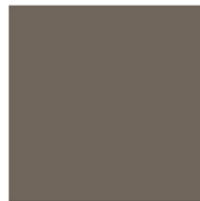

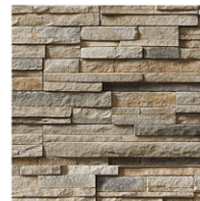

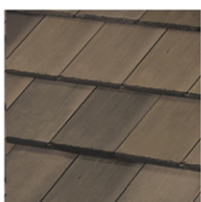





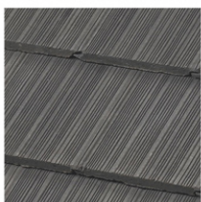
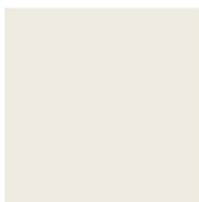

SCHEME	VILLA TILE	FLAT TILE	BODY 1	BODY 2	TRIM & GARAGE DOOR	ACCENT & FRONT DOOR	STONE	BRICK
SCHEME 13	1VICS3233 BROWN BLEND 	1FACS1132 CHARCOAL BROWN BLEND 	KMW28-1 CLAM 	KM5784-3 CREEK BAY 	KM5792-3 STACKED STONE 	KM4582 BEAVER PELT 	BLACK MOUNTAIN PRO-FIT ALPINE LEDGESTONE 	MARSH POINTE 
SCHEME 14	1VICS7330 VERONA CLAY 	1FACS1132 CHARCOAL BROWN BLEND 	KMW10-1 POGO SANDS 	KM5785-3 COUNTRY CLUB 	KM5777 CANNERY PARK 	KM4897-5 YIN MIST 	GRAND MESA COUNTRY LEDGESTONE 	TOBACCO ROAD 
SCHEME 15	1VICS0024 DESERT SAGE 	1FBCF1132 CHARCOAL BROWN BLEND 	KM4633-1 CZECH BAKERY 	KM4657-3 CAPPUCCINO FROTH 	KMW6-1 LILY WHITE 	KM5764-3 MENDOCINO HILLS 	HUDSON BAY COUNTRY LEDGESTONE 	SANDY CREEK 
SCHEME 16	1VICS3233 BROWN BLEND 	1FBCF1430 CHARCOAL BLEND 	KM4601-2 DRIED GRASS 	KM4574-3 DRY DOCK 	KM4571-1 COBBLESTONE STREET 	KM4812-5 JUNGLE COVER 	ECHO RIDGE PRO-FIT ALPINE LEDGESTONE 	OLD EDISTO 
SCHEME 17	1VICS0024 DESERT SAGE 	1FBCF1430 CHARCOAL BLEND 	KM4594-2 BAY AREA 	KM4711-1 BAUHAUS TAN 	KM4595-3 CLAY BATH 	KMA76-5 LOG CABIN 	ASPEN COUNTRY LEDGESTONE 	SANDY CREEK 
SCHEME 18	1VICS3233 BROWN BLEND 	1FACS1132 CHARCOAL BROWN BLEND 	KM5766-1 WHISPER RIDGE 	KM4937 PAW PRINT 	KMW24-1 BUD'S SAILS 	KM4932-5 RUB ELBOWS 	SUMMIT PEAK PRO-FIT ALPINE LEDGESTONE 	COASTAL BLUFF 

ROOFING: Boral Concrete Tile or Equivalent
 STONE: Boral Cultured Stone/Cultured Brick or Equivalent
 PAINT: Kelly Moore or Equivalent

SUBDIVISION: **STONEBROOK**

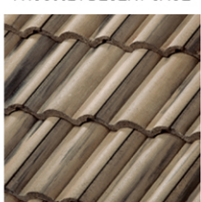
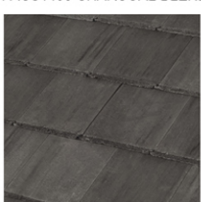
BRENTWOOD, CA

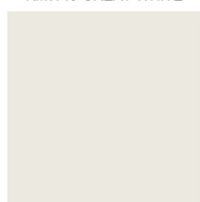
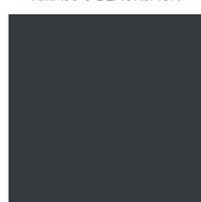
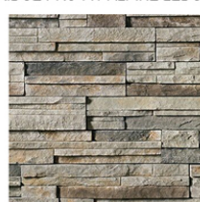
COLOR BOARD

SCHEME	VILLA TILE	FLAT TILE	BODY 1	BODY 2	TRIM & GARAGE DOOR	ACCENT & FRONT DOOR	STONE	BRICK
SCHEME 19	1VICS3233 BROWN BLEND 	1FACS0330 APPALACHIAN BLEND 	KM4706-3 RUSTIC HACIENDA 	KM5786-5 RIVER BANK 	KM4704-2 DUSTY TRAIL RIDER 	HLS4201 ADOBE WHITE 	GRAY SOUTHERN LEDGESTONE 	OLD EDISTO 
SCHEME 20	1VICS3233 BROWN BLEND 	1FACS1430 CHARCOAL BLEND 	KM4942-2 TIN MAN 	KM4945-6 SECRET PASSAGEWAY 	KM4786-1 FRESH LINEN 	KM407 CARBON 	BLACK MOUNTAIN PRO-FIT ALPINE LEDGESTONE 	TOBACCO ROAD 
SCHEME 21	1VICS0024 DESERT SAGE 	1FBCF1430 CHARCOAL BLEND 	305 IRONWOOD 	KM4938 GROUCHY BADGER 	27 BONE 	KM4862-5 OLD SCHOOL 	SUMMIT PEAK PRO-FIT ALPINE LEDGESTONE 	TOBACCO ROAD 
SCHEME 22	1VICS7330 VERONA CLAY 	1FACS1132 CHARCOAL BROWN BLEND 	KM4663-2 GOLD WASH 	KM5779-3 EAGLE'S MEADOW 	KMW14-1 GARLIC CLOVE 	KM4519-5 TURKISH COFFEE 	WOLF CREEK COUNTRY LEDGESTONE 	COASTAL BLUFF 
SCHEME 23	1VICS3233 BROWN BLEND 	1FBCF1430 CHARCOAL BLEND 	46 ACOUSTIC WHITE 	KM5766-1 WHISPER RIDGE 	KM5771-2 APPLE HILL 	KM5772 PALM LANE 	HUDSON BAY COUNTRY LEDGESTONE 	MARSH POINTE 
SCHEME 24	1VICS0024 DESERT SAGE 	1FACS1430 CHARCOAL BLEND 	KM4941 CITY DWELLER 	KM5826-3 VOLCANIC ROCK 	KMW49 GREAT WHITE 	KMA90-5 BLACKJACK 	ECHO RIDGE PRO-FIT ALPINE LEDGESTONE 	COASTAL BLUFF 

ROOFING: Boral Concrete Tile or Equivalent
 STONE: Boral Cultured Stone/Cultured Brick or Equivalent
 PAINT: Kelly Moore or Equivalent